



WDS / WDD

Remote Air Cooled Condenser



Description:

Witt's Remote Air Cooled Condensers are designed to provide a wide array of solutions focusing on performance, energy efficiency, reduced sound output and other requirements of today's demanding marketplace. Working closely with market leading customers to solve real world problems, Witt incorporates the wisdom of lessons learned into its design philosophies resulting in products that exceed the needs of the grocery, supermarket, industrial cooling and commercial warehousing industries.

Standard Features:

- Direct drive motor arrangement
- Vertical or horizontal air flow
- 1140, 850, 550 RPM or Variable Speed EC (VSEC) motors
- Reduced decibel ratings from slower speed or VSEC motors
- Motors have inherent thermal overload protection
- High efficiency Copper tube, Aluminum fin coils
- Leak tested at 450 PSIG
- Reduced refrigerant charge requirements
- Vinyl coated heavy gauge steel fan guards for long life
- Heavy gauge galvanized steel construction for superior corrosion resistance (other materials and coatings optional)
- Internal dividers isolate each fan cell

Options:

- Fan cycling head pressure control (Ambient or Pressure)
- Flooded head pressure control
- Sub-cooling circuit
- Multi-sectioned coils
- Copper fins
- Wide selection of coated coils for corrosion protection
- Through-the-door disconnect switch
- Individual motor fusing
- Individual or paired motor contactors
- Control board with or without transformer
- Variable frequency drives
- Variable speed header end fan (not available with VFD's or VSEC motors)
- Hinged venturi panels
- Removable side access panels
- Extended condenser legs



Remote Air Cooled Condenser

Table of Contents

Nomenclature	2
Standard Features and Options	3
Condenser Selection	4-9
Performance and Specifications	
Variable Speed EC Models	10-11
1140 RPM Models	12-13
850 RPM Models w/ 0.33HP or 1-1/2HP motors	14-15
850 RPM Models w/ 1HP motors	16-17
550RPM Models	18-19
Dimensional drawings	20

MODEL NUMBER NOMENCLATURE

<u>W</u> <u>I</u>	<u>D</u> <u>II</u>	<u>S</u> <u>III</u>	<u>082</u> <u>IV</u>	<u>G</u> <u>V</u>	<u>B</u> <u>VI</u>	<u>5</u> <u>VII</u>	<u>B</u> <u>VIII</u>	<u>1</u> <u>IX</u>	<u>2</u> <u>X</u>	<u>A</u> <u>XI</u>	<u>1</u> <u>XII</u>	<u>A</u> <u>XIII</u>
I. Model Series												
W – Witt				2 – Copper fins								
				3 – Al + AST coating								
II. Unit type				4 – Al + Blygold								
D – Condenser				5 – Al + Bronze Glow								
				6 – Al + Heresite								
III. Series				7 – Al + Polyester coat } Post Coat Materials								
S – Single fan wide				X – Other								
D – Double fan wide												
IV. Capacity – Three Number Characters				X. Housing Material and Coatings								
				1 – Aluminum								
				2 – Galvanized								
V. Voltage Code				4 – Pueblo Tan pre-paint								
A – 115/1/60				7 – Stainless Steel 316L								
D – 208-230/1/60				X – Other								
E – 208-230/3/60												
F – 460/1/60				XI. Unit Design Configuration								
G – 460V/3/60				A – Vertical Fan Discharge, Standard Legs								
H – 575/1/60				B – Vertical Fan Discharge Floating Coil, Standard Legs								
J – 575V/3/60				C – Vertical Fan Discharge, Legs at every location								
				D – Vertical Fan Discharge Floating Coil, Legs at every location								
VI. Motor/Fan Type				E – Vertical Fan Discharge, 30" Extended Legs								
A – 1140 RPM, 0.33 HP, Metal Blade				F – Vertical Fan Discharge Floating Coil, 30" Extended Legs								
B – 1140 RPM, 1.5 HP, Metal Blade				G – Vertical Fan Discharge, 48" Extended Legs								
C – 850 RPM, 0.25 HP, Metal Blade				H – Vertical Fan Discharge Floating Coil, 48" Extended Legs								
D – 850 RPM, 1.5 HP, Metal Blade				J – Vertical Fan Discharge, 60" Extended Legs								
E – 550 RPM, 1/3 HP, Metal Blade				K – Vertical Fan Discharge Floating Coil, 60" Extended Legs								
F – 550 RPM, 1/3 HP, FB2				L – Vertical Fan Discharge, 72" Extended Legs								
G – 900 RPM, 1.5 HP, Variable Speed EC Motor & Fan Assembly				M – Vertical Fan Discharge Floating Coil, 72" Extended Legs								
H – 1140 RPM, 0.5 HP Totally Enclosed, Metal Blade				N – Horizontal Fan Discharge,								
J – 1140 RPM, 1.5 HP Totally Enclosed, Metal Blade				P – Horizontal Fan Discharge, Floating Coil								
K – 1140 RPM, 1.0 HP, Metal Blade				Q – Vertical Fan Discharge, 21" Extended Legs								
L – 850 RPM, 1.0 HP, Metal Blade				R – Vertical Fan Discharge Floating Coil, 21" Extended Legs								
X – Other				S – Vertical Fan Discharge, 21" Legs at every location								
VII. Length in Fans – A number between 1 and 7				T – Vertical Fan Discharge Floating Coil, 21" Legs at every location								
				U – Vertical Fan Discharge, Export Legs								
				V – Vertical Fan Discharge Floating Coil, Export Legs								
				X – Other								
VIII. Coil Density				XII. Circuit Splitting Options								
A – 8 fpi				1 – Full								
B – 10 fpi				2 – 50-50								
C – 12 fpi				3 – 50-25-25								
D – 14 fpi				4 – 25-25-25-25								
X – Other				X – Other								
IX. Coil Material and Coating Options				XIII. Revision Code – Single Alphanumeric Character								
1 – Aluminum fins												

Remote Air Cooled Condenser

Standard and Optional Features

DESCRIPTION	Notes	UNIT MODEL	
		Small Models 001 to 011	Large Models 008 to 250
General Construction and Configuration			
Vertical Air Discharge Configuration	D	Std	Std
Horizontal Air Discharge Configuration	D,G	Opt	Opt
Galvanized Steel Frame and Casing		Std	Std
Aluminum Casing		Opt	Opt
White painted Galvanized Steel Casing		Opt	Opt
Pueblo Tan pre-paint Galvanized Steel Casing		Opt	Opt
AST Coated Galvanized Casing		Opt	Opt
Stainless Steel 304 Casing		Opt	Opt
Stainless Steel 316 Casing		Opt	Opt
Heavy Gauge Galvanized Steel Legs (Vert. Disch):			
		Leg Length	
		21", 30", 48", 60" or 72"	
	A	15" (Std) N/A	18" (Std) Opt
Condenser Coil			
Heavy Gauge Aluminum Tube Sheets		Std	Std
Copper Tubes Mechanically Expanded into Aluminum Fins		Std	Std
Special Fin Materials: Copper Fin Stock		Opt	Opt
Polyester-Coated Fin Stock		Opt	Opt
Aluminum Fins with AST ElectroFin™, Heresite, Bronze Glow or Blygold Coated Coils		Opt	Opt
Floating coil design		Opt	Opt
Multi-Sectioning (No extra Charge)	B	Opt	Opt
Sub-Cooling Circuits (No extra Charge)		Opt	Opt
Fan Section			
6-Pole (1140 RPM), 1-Phase or 3-Phase Fan Motors:			
		Open Type	Std
		Totally Enclosed	Opt
		Open Type	Opt
8-Pole (850 RPM), 1-Phase or 3-Phase Fan Motors		F	Opt
Variable-Speed Fan Motors on Header End - See Control Panel Options		C	Opt
Fan Motor Mounting: Welded heavy gauge rod mounting frames		G	Std
Models with Motor code G include Variable Speed EC motor and fan assemblies			N/A
Fully Baffled Fan Modules			Std
Flip Top' Hinged Fan Panels - Access for Coil Cleaning and Fan/Motor Service	G		Opt
Side Access Panels - for Ease of Coil Cleaning			N/A
Gravity Dampers	G		Opt
Control Panel			
Mounting Location: Opposite Header End			Std
Header end, Left or Right Side			Opt
Temp. or Press. Fan Cycling - Individual or Paired-Fan Contactors (Must specify)	G		Opt
Custom Fan Cycling Wiring and Logic			Opt
Variable Speed Control: Penn P-66 Pressure Controlled	C, G		Opt
Output Relay Boards for Computerized Fan Cycling (Computer control by others)			Opt
Analog output board (for units with Variable Speed EC motors)			Opt
Motor Fusing - Individually or in Pairs			Opt
Circuit Breakers			Opt
Fan Control Circuit Toggle Switches			Opt
Control Transformer			Opt
Fused or Non-Fused Disconnect Switch (Mounted)			Opt
VFD - Not available for models with Variable Speed EC Motors			Opt
Refrigerant Specialties			
Flooded-Condenser Control Valve System			Opt
Field Manifold Kit	B		Opt
Shipping			
Vertical Discharge Models			
Small Style Condensers	D	See note D	N/A
Large Style Condensers - Legs collapsed for shipping, must extend during installation		N/A	Std
Horizontal Discharge Models			
Legs Disassembled - Unit is Cartoned or Crated	D	See note D	Std

Notes:

- A. Contact factory
- B. All double fan-width units are two-section as standard. Requires field manifold kit for single-section operation.
- C. Header-End (lead fans) only.
- D. Legs are disassembled for small condenser models. Units are shipped in carton or crate. Models thru size 011 can be mounted in either horizontal or vertical configuration depending on method of leg assembly. Consideration must be given to the electrical box when mounted for horizontal air discharge. Large style condensers must be special ordered for use in horizontal discharge arrangement.
- E. 1140 RPM Single phase motors available for sizes up to 022 only.
- F. 850 RPM single phase motors available for small condensers thru size 009 only.
- G. Not available for units with EC motors.

Remote Air Cooled Condenser

Condenser Selection

Air-cooled condenser capacity ratings are based on the total heat rejection of the refrigeration system. Total heat of rejection is the sum of the net refrigeration effect and heat of compression added to the refrigerant in the compressor.

The heat of compression varies with the compressor design, so the compressor manufacturer's information should be used whenever possible. If the compressor manufacturer's heat of compression information is not available, Tables 1 and 2 (page 5) may be used to determine the heat of compression.

The following formulas may be used to calculate the total heat rejection (THR) for systems that fall outside the normal limits of single stage compressor applications, such as compound or cascade systems.

Suction cooled hermetic compressors:

$$\text{THR} = \text{Compressor Capacity (BTUH)} + (3413 \times \text{KW})$$

Open Compressors

$$\text{THR} = \text{Compressor Capacity (BTUH)} + (2545 \times \text{BHP})$$

ELEVATION CORRECTION

Elevation above sea level has an effect on the performance of air cooled condensers. Divide the required capacity by the Elevation Correction Factor in the table on page 5 to correct the requirement to Sea Level Conditions. The proper condenser can then be selected from the appropriate table on Pages 10,12,14,16 or 18.

SINGLE SECTION CONDENSERS

All units are available for single section applications. All double fan width units are furnished with dual section coils and can be converted in the field for single section installations.

SELECTION EXAMPLE

Given:

- Ambient Air Temperature = 95° F
- Maximum Condensing Temperature = 110° F
- Evaporator Temperature = 20° F
- Refrigerant = R-404A
- Compressor Capacity = 290,000 BTU
- Compressor Type = Suction Cooled Semi-Hermetic

Solution:

Multiply the compressor capacity by the heat of compression factor to calculate the required total heat of rejection (THR). Table 1 shows that for 110°F condensing temperature and 20° F evaporator temperature, the heat of compression factor is 1.33. The required total heat rejection (THR) is:

$$290,000 \times 1.33 = 385,700 \text{ BTUH THR}$$

Divide the BTUH THR by the design condensing temperature of 15°F TD. (TD = Condensing Temperature - Ambient Temperature)

$$385,700 \div 15 = 25,713 \text{ BTUH per } 1^\circ\text{FTD}$$

Convert BTUH to MBH.

$$25,713 \text{ BTUH} \div 1000 = 25.713 \text{ MBH per } 1^\circ\text{FTD}$$

The correct selection of a single fan width unit with 1140 RPM fan motors (page 12) is a model WDS048*B3 with a capacity of 26.0 MBH @ 10FPI.

Since the unit selection will almost never have the exact required capacity, the actual TD will vary slightly from the design TD. The actual TD can be calculated using the following formula:

$$\text{Actual TD} = \frac{\text{Design THR}}{\text{Actual Condenser THR}} \times \text{Design TD}$$

For this example the actual TD would be:

$$\text{Actual TD} = \frac{25.7}{26} \times 15 = 14.8^\circ\text{FTD}$$

Remote Air Cooled Condenser

Table 1: Heat of Compression Factors
Suction Cooled Compressors

Evap Temp °F	Condensing Temperature °F								
	90	95	100	105	110	115	120	125	130
-40	1.66	1.70	1.73	1.76	1.80	1.90	2.00	†	†
-35	1.61	1.64	1.68	1.70	1.74	1.82	1.90	†	†
-30	1.57	1.60	1.62	1.65	1.68	1.74	1.80	†	†
-25	1.53	1.56	1.58	1.60	1.63	1.67	1.72	†	†
-20	1.49	1.51	1.53	1.55	1.58	1.61	1.65	†	†
-15	1.46	1.48	1.50	1.51	1.54	1.57	1.61	†	†
-10	1.42	1.44	1.46	1.48	1.50	1.53	1.57	1.60	1.64
-5	1.39	1.41	1.43	1.45	1.47	1.50	1.53	1.56	1.60
0	1.36	1.38	1.40	1.42	1.44	1.47	1.50	1.53	1.56
+5	1.33	1.35	1.37	1.39	1.41	1.43	1.46	1.49	1.52
+10	1.31	1.32	1.34	1.36	1.38	1.40	1.43	1.46	1.49
+15	1.28	1.30	1.32	1.33	1.35	1.37	1.40	1.43	1.46
+20	1.26	1.27	1.29	1.31	1.33	1.35	1.37	1.40	1.43
+25	1.24	1.25	1.27	1.29	1.31	1.33	1.35	1.37	1.40
+30	1.22	1.23	1.25	1.26	1.28	1.30	1.32	1.34	1.37
+35	1.20	1.21	1.23	1.25	1.26	1.27	1.29	1.31	1.34
+40	1.18	1.19	1.21	1.23	1.24	1.25	1.27	1.29	1.31
+45	1.16	1.17	1.19	1.21	1.22	1.23	1.25	1.26	1.28
+50	1.14	1.15	1.17	1.19	1.20	1.22	1.23	1.24	1.26

A. † Beyond the normal limits for single stage compressor application.

Table 2: Heat of Compression Factors
Open Compressors

Evap Temp °F	Condensing Temperature °F								
	90	95	100	105	110	115	120	125	130
-30	1.37	1.39	1.42	1.44	1.47	†	†	†	†
-20	1.33	1.35	1.37	1.39	1.42	1.44	1.47	†	†
-10	1.28	1.30	1.32	1.34	1.37	1.39	1.42	1.44	1.47
0	1.24	1.26	1.28	1.30	1.32	1.34	1.37	1.39	1.41
+10	1.21	1.23	1.24	1.26	1.28	1.30	1.32	1.34	1.36
+20	1.17	1.18	1.20	1.22	1.24	1.26	1.28	1.30	1.32
+30	1.14	1.15	1.17	1.18	1.20	1.22	1.24	1.25	1.27
+40	1.12	1.14	1.15	1.16	1.17	1.18	1.20	1.21	1.23
+50	1.09	1.11	1.12	1.13	1.14	1.16	1.17	1.19	1.20

A. † Beyond the normal limits for single stage compressor application.

Table 3: Elevation Correction Factors

Elevation (ft)	1000	2000	3000	4000	5000	6000	8000	1000	12000	14000	16000
Correction Factor	0.94	0.93	0.90	0.88	0.86	0.83	0.79	0.75	0.71	0.66	0.62

Remote Air Cooled Condenser

Multi-Section Condensers

Air-cooled condensers with more than one section are available for applications where multiple refrigeration systems are connected to the same condenser. Multi-sectioning, except for small condensers, is covered in this section.

The condenser coil is divided into the proper number of sections and each section is supplied with an inlet and outlet connection. Each section is tagged for identification. When ordering, the sections must be placed in numerical sequence. The sections will be arranged in sequence with the number one section being on the left end when facing the header end of the unit.

Example: Multi-Section Condenser Selection

Given:

Refer to Table 4, the Multi-Section Calculation Form below. Four suction cooled semi-hermetic compressors are shown with their operating conditions. Design ambient temperature is 95° F.

Procedure:

1. Complete the customer data in columns 1 through 6 in Table 4.
2. Fill in the heat of compression factors in column 7. If the compressor manufacturer's data is not available, use values from tables 1 and 2.
3. Multiply the values in column 6 by the values in column 7 and tabulate the results in column 8.
4. Next, divide the heat rejection values in column 8 by the design TD values in column 3 and enter the results in column 9.
5. Add all of the items in column 9 to obtain the total MBH required at 1° FTD. Use this value and the procedure on Page 4 to select the proper condenser model. For this example, the total MBH is 25.64. Therefore, the unit with 1140 RPM fan motors and double fan-width configuration, having enough capacity to meet this requirement, is an WDD041*B2 with 14 FPI.
6. MBH per face tube values can be found by dividing the unit's capacity, found in the performance data tables, by the number of face tubes listed in Table 5. Be sure to apply the corresponding correction factors for refrigerants other than R-404A or R-407A. Enter the MBH per face tube value in column 10.

For Sections No. 1 & 2 in Table 4, the unit's capacity can be found by multiplying the R-22 correction factor (1.02) by the value in the R-404A table (26.1) on page 12. Divide this capacity by the number of face tubes available for the WDD041*B2 listed in Table 5.

$$\text{MBH per face tube} = \frac{26.1 \times 1.02}{72} = 0.370$$

7. To determine the number of face tubes required for each section, divide column 9 by column 10 and enter the results in column 11.
8. Each section's number of face tubes in column 11 is a mathematical value and must be rounded off to a whole number and entered into column 12. Round each number off such that the section size assigned to each system is no smaller than 10% undersized.
9. Total the values in column 12. The sum must equal the number of face tubes available for the WDD041*B2 as shown in Table 5. If it does not, one or more of the column 12 numbers will have to be adjusted so the sum does equal the available face tubes.
10. The actual TD in each coil section may vary slightly from the design TD. The actual TD can be calculated using the following formula:

$$\text{TD} = \frac{\text{Design TD} \times \text{adjusted THR @ 1°TD}}{\text{MBH per tube @ 1°TD} \times \text{No. of Tubes used}}$$

The actual TD for Section No. 3 would be:

$$\text{TD} = \frac{10 \times 4.98}{0.363 \times 15} = 9.1^\circ\text{F}$$

Table 4: Multi-Section Calculation Form

1	2	3	4	5	6	7	8	9	10	11	12
Section No.	Refrig. Type	Design TD (°F)	Cond. Temp. (°F)	Evap. Temp. (°F)	Compressor Capacity (MBH)	Heat of Compression Factor	Heat Rejection	Adjusted THR (MBH) 1°F TD	MBH Per Face Tube	No. of Face Tubes Required	No. of Face Tubes Selected
1	22	15	110	20	96.5	1.33	128.3	8.56	0.370	23.13	24
2	22	15	110	20	81.1	1.33	107.9	7.19	0.370	19.43	20
3	404	10	105	-25	31.1	1.6	49.8	4.98	0.363	13.71	14
4	404	10	105	-25	28.9	1.7	49.1	4.91	0.363	13.53	14

Head Pressure Control Options and Refrigerant Charge Calculations

Flooded Condenser

The Flooded Condenser Head Pressure Control Option maintains adequate condensing pressure while operating in low ambient temperatures. By flooding the condenser with liquid refrigerant, the amount of coil surface available for condensing is reduced. The resulting reduction in capacity ensures proper operation of the thermal expansion valve.

This option requires a modulating three-way valve, dependent on refrigerant discharge pressure, be placed at the condenser outlet. A fall in ambient temperature causes a corresponding fall in discharge pressure. The valve modulates allowing discharge gas to flow to the receiver, creating a higher pressure at the condenser outlet. This higher pressure reduces the flow out of the condenser, causing liquid refrigerant to back up in the coil. Flooding the condenser reduces the available condensing surface and raises the condensing pressure so that adequate high-side pressure is maintained.

A larger receiver and additional refrigerant are required for systems with flooded condenser control. The receiver can be conveniently installed directly under the condenser in most applications. However, if the system will be operational in ambient temperatures below 55° F, the receiver should be located in a warm environment or heated. In this situation, a check valve must be installed in the line between the receiver and expansion valve. This prevents refrigerant migration from the receiver to the condenser.

The amount of additional refrigerant charge is based on the lowest expected winter operating temperature and the design TD. In addition to the condenser charge, the operating charges of the evaporator, receiver and refrigerant lines must be added to determine the total system refrigerant charge. The pump-down capacity (80% of full capacity) of the receiver must be at least equal to the total system charge.

Table 5 shows the standard summer charge when using R-404A. The additional charge required for flooded condenser operation with a design TD of 15°F is also shown. Additional charge for alternate design TDs can be found using the correction factors in Table 6. For flooded condenser control only,

$$\text{total charge} = \text{summer charge (Table 5)} + \text{additional charge (Table 5)} \times \text{design TD correction factor (Table 6)}$$

Example: Single Section Unit with Flooded Condenser Head Pressure Control

Given:

An WDD055*B Condenser with an R-404A summer charge of 24.4 lbs. (See Table 5) has a design TD of 10° F and will operate at a minimum ambient of 0° F.

Solution:

The additional charge needed to operate at 0° F can be found in Table 5 (63.3 lbs.). Because the unit has a design TD of 10° F, the additional charge must be multiplied by a correction factor of 1.04 as shown in Table 6. Therefore, the required additional charge is $63.3 \times 1.04 = 65.8$ lbs. The total operating charge for a minimum ambient of 0° F and a 10° design TD is $24.4 + 65.8 = 90.2$ lbs.

Example: Multi-Section Unit with Flooded Condenser Head Pressure Control

Given:

An WDS017 condenser split into two sections. One section has 22 face tubes of R-404A at a 10° TD and the other section has 14 face tubes of R-22 at a 15° TD. The unit will operate at a minimum ambient of 20° F.

Solution:

To calculate the winter charge for each section, the summer charge and additional charge for low ambient must be found. The summer charge can be calculated by multiplying the number of face tubes in the section by the charge per face tube value in Table 5. Next, divide the number of face tubes in the section by the total number of face tubes and multiply by the additional charge required for a minimum ambient of 20° F. Make sure to apply correction factors for design TDs other than 15° and for refrigerants other than R-404A or R-507. Adding the summer charge and additional charge for low ambient will yield the total winter charge.

For the R-404A section, the summer charge is $22 \text{ tubes} \times 0.23 \text{ lbs. per face tube} = 5.06$ lbs. The additional charge equals the ratio of tubes in the section to total tubes times the additional charge at 20° F with a 15° FTD times the TD correction factor from Table 6, or $22/36 \times 19.1 \times 1.05 = 12.26$ lbs. The winter charge is $5.06 + 12.26 = 17.32$ lbs.

For the R-22 section, the summer charge must be multiplied by a refrigerant correction factor of 1.13 as seen in the Table 5 footnotes. The summer charge is $14 \times 0.23 \times 1.13 = 3.64$ lbs. The additional charge calculation also requires the use of the correction factor. The additional charge is $14/36 \times 19.1 \times 1.13 = 8.39$ lbs. The winter charge is $3.64 + 8.39 = 12.02$ lbs.

Remote Air Cooled Condenser

Table 5: Additional Refrigerant Charge for Flooded Condensers

Unit Size	Number of Face Tubes	R-404A & 507*		Additional Charge Required for Low Ambient Temperatures, 15°F Design TD [†]							
		Charge Per Face Tube (Lbs.)	Total Summer Charge (Lbs.)								
Motor Speed (RPM)											
SINGLE FAN-WIDTH UNITS				MINIMUM AMBIENT TEMPERATURE (°F)							
1140	850	550	VSEC	60	40	20	0	-20			
009	009	008	011	36	0.11	4.1	5.9	8.3	9.6	10.5	11.2
011	013	010	015		0.17	6.1	9.1	12.7	14.5	15.8	16.9
013	014	011	017		0.23	8.1	12.0	16.0	18.3	20.7	21.8
017, 021	---	015	022		0.23	8.1	11.8	16.6	19.1	20.9	22.4
022, 028	019, 026	019	030		0.34	12.2	18.2	25.3	29.0	31.7	33.8
033	029	021	033		0.45	16.2	24.0	31.9	36.6	41.3	43.7
041	039	029	045		0.51	18.3	27.3	38.0	43.5	47.5	50.7
048	044	032	051		0.68	24.3	36.0	47.9	54.9	62.0	65.5
055	051	039	059		0.68	24.4	36.5	50.7	58.1	63.3	67.6
064	058	043	067		0.90	32.4	48.0	63.8	73.2	82.7	87.4
070	063	049	073		1.41	50.9	80.3	111.0	126.9	138.2	147.4
082	077	054	089		1.93	69.6	93.2	135.8	159.1	175.8	189.1
098	092	068	107		2.32	83.5	111.8	163.0	190.9	211.0	226.9
114	107	079	125		2.71	97.4	130.5	190.1	222.7	246.1	264.7
DOUBLE FAN-WIDTH UNITS					72						
041	037	030	043			0.23	16.2	23.7	33.2	38.3	41.9
055	052	039	059	0.34		24.4	36.5	50.7	58.1	63.3	67.6
064	056	043	067	0.45		32.4	48.0	63.8	73.2	82.7	84.4
082	076	058	089	0.51		36.6	96.3	133.2	152.3	165.9	172.6
097	087	064	102	0.68		48.6	72.0	95.8	109.7	124.0	131.0
110	103	077	118	0.68		48.8	72.9	101.3	116.1	126.7	135.2
127	116	086	135	0.90		64.8	96.0	127.7	146.3	165.4	174.7
140	126	098	147	1.41		101.7	160.6	222.0	253.8	276.5	294.9
164	152	108	179	1.93		139.2	186.4	271.6	318.2	351.6	378.2
196	183	136	214	2.32		167.0	223.7	325.9	381.8	421.9	453.8
229	213	158	250	2.71		194.8	261.0	380.2	445.5	492.2	529.5

† Based on 90°F Condensing Temperature

* For R-22 multiply by 1.13

* For R-134A multiply by 1.15

* For R-410A multiply by 1.02

* For R407A or R407C, multiply by 1.09

Table 6: Low Ambient Design TD Correction Factors

Minimum Ambient Temperature (°F)	Design TD				
	30	25	20	15	10
60	0	0.40	0.76	1.00	1.24
40	0.73	0.84	0.92	1.00	1.09
20	0.86	0.92	0.95	1.00	1.05
0	0.91	0.94	0.97	1.00	1.04
-20	0.93	0.96	0.98	1.00	1.02

Fan Cycling Control Option

The cycling of condenser fans provides an automatic means of maintaining condensing pressure control at low ambient air temperature conditions. It also results in substantial fan motor power savings in lower ambient. Temperature sensing thermostats or pressure controls determine whether the motor is on or off. The minimum ambient temperatures for units with the Fan Cycling Control Option can be found in Table 7.

The Fan Cycling Control Option consists of a weatherproof enclosure, fan contactors, and either ambient thermostat(s) or pressure control(s). The enclosure is factory mounted and completely factory wired. Power must be supplied from a fused disconnect switch to the power circuit terminal block; control circuit power must be supplied to the control terminal block.

Table 8 shows the recommended temperature set points for the thermostats. Thermostat 1 is for the second fan from the header end, Thermostat 2 for the third fan from the header end, etc. The fan(s) nearest the header end must run continuously, and cannot be cycled.

Fan Speed Control Option - Available only with Fan Cycling Control Option

Designed to enhance the performance of the Fan Cycling Control Option by reducing the RPM and air volume of the lead (header end) fan motor(s) after all other (lag) fans have cycled off. The lead fan(s) must run continuously, even in the lowest ambient temperature. By reducing their CFM, adequate head pressure can be maintained at lower ambient temperatures without resorting to flooded condenser head pressure controls. This option includes a Johnson P66 or P266 Speed Controller, 24 volt transformer, single phase fan motor and pressure line piped from the last return bend in the circuit opposite the header end to the speed control. Double fan-width models require two controllers for the two lead fan motors. All components are factory mounted and wired. Controller decreases fan motor RPM as head pressure decreases. See Table 7 for minimum ambient temperatures for units with both the Fan Cycling Control Option and Fan Speed Control Option.

Remote Air Cooled Condenser

Table 7: Minimum Ambient with Fan Cycling Control

# of Fans Long	Design TD*	Minimum Ambient Temp. (°F)	
		Without Fan Speed Control	With Fan Speed Control
2	30	35	10
	25	45	23
	20	54	37
	15	63	50
	10	72	63
3	30	15	-16
	25	28	2
	20	40	19
	15	53	37
	10	65	55
4	30	-2	-25
	25	13	-15
	20	28	6
	15	44	27
	10	59	48
5	30	-17	-25
	25	1	-25
	20	19	-5
	15	36	19
	10	54	42
6	30	-25	-25
	25	-10	-25
	20	10	-14
	15	30	12
	10	50	38
7	30	-25	-25
	25	-19	-25
	20	3	-22
	15	24	6
	10	46	34

* Based on approximately 90°F condensing temperature.

Table 8: Recommended Fan Cycling Thermostat Settings

# of Fans Long	Design TD*	Thermostat Setpoint (°F)						
		1	2	3	4	5	6	
2	30	60						
	25	65						
	20	70						
	15	75						
	10	80						
	30	47	60					
3	25	54	65					
	20	61	70					
	15	69	75					
	10	76	80					
	30	35	51	60				
	4	25	45	58	65			
20		54	64	70				
15		63	71	75				
10		72	77	80				
30		25	43	53	60			
5		25	36	51	60	65		
	20	47	59	66	70			
	15	57	67	72	75			
	10	68	74	78	80			
	30	15	35	47	55	60		
	6	25	28	45	54	61	65	
20		40	54	61	66	70		
15		53	63	69	72	75		
10		65	72	76	78	80		
30		6	28	41	50	56	60	
7		25	20	39	49	56	61	65
	20	34	49	57	63	67	70	
	15	48	59	66	70	73	75	
	10	62	69	74	77	79	80	

* Based on approximately 90°F condensing temperature.

Diagram 1

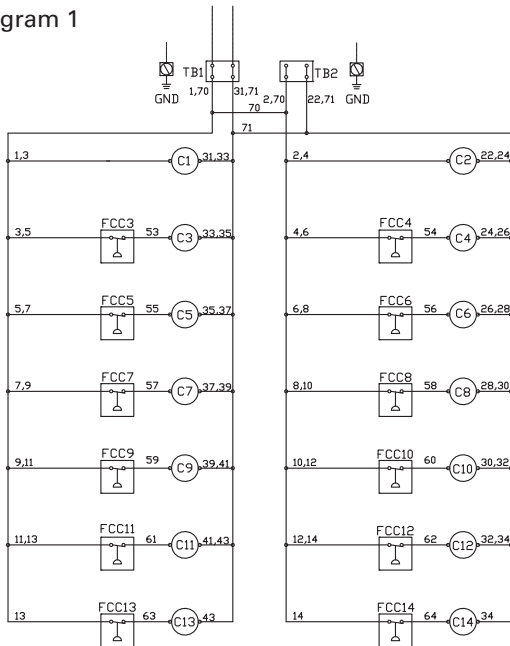
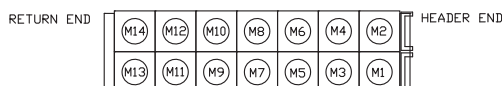
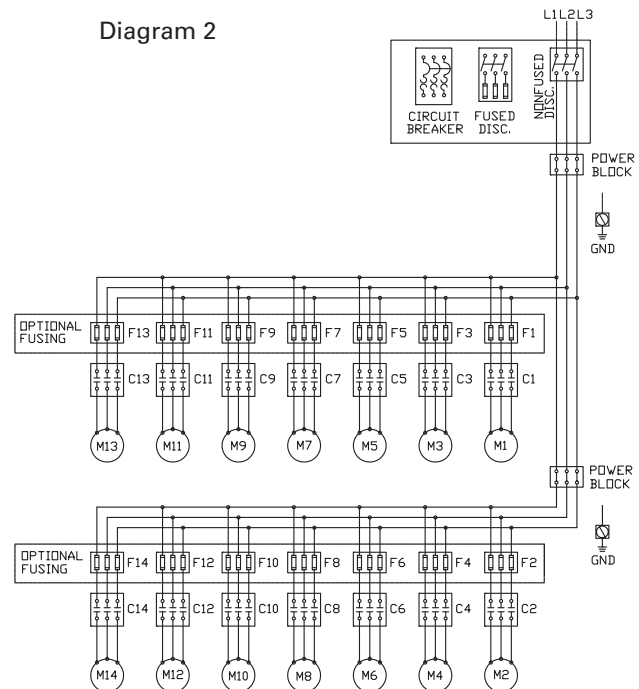

Diagram 2



- LEGEND:
- C1-C14 FAN CONTACTORS
 - M1-M14 FAN MOTORS
 - F1-F14 MOTOR FUSES
 - TB1-TB2 TERMINAL BOARD
 - FCC3-FCC14 FAN CYCLING CONTROLS
 - FACTORY WIRING
 - FIELD WIRING

* FCC3 - FCC14 are only present in units with the Fan Cycling Control Option, and can be either ambient temperature controls or pressure controls.

Remote Air Cooled Condenser

Performance Data - THR MBH 1°F TD

Variable Speed EC Fan Motors

Unit Size	Refrigerants-404A & 507				Refrigerant-407A			
	FPI				FPI			
	8	10	12	14	8	10	12	14
SINGLE FAN-WIDTH MODELS								
WDS011*G1B12A1A	5.2	5.9	6.4	6.9	4.9	5.6	6.0	6.5
WDS015*G1B12A1A	7.2	8.0	8.6	9.1	7.0	7.8	8.4	8.9
WDS017*G1B12A1A	8.3	9.1	9.5	10.1	8.3	9.2	9.6	10.2
WDS022*G2B12A1A	10.3	11.7	12.8	13.8	9.7	11.0	12.1	13.1
WDS030*G2B12A1A	14.4	16.0	17.2	18.2	14.0	15.6	16.8	17.7
WDS033*G2B12A1A	16.6	18.1	19.0	20.1	16.7	18.2	19.2	20.2
WDS045*G3B12A1A	21.6	24.1	25.8	27.3	21.1	23.5	25.2	26.7
WDS051*G3B12A1A	25.4	27.7	29.2	30.9	25.5	27.9	29.4	31.0
WDS059*G4B12A1A	28.7	31.9	34.2	36.2	28.0	31.1	33.4	35.3
WDS067*G4B12A1A	33.5	36.5	38.5	40.6	33.7	36.7	38.7	40.9
WDS073*G5B12A1A	36.1	39.7	42.5	44.5	35.9	39.4	42.2	44.2
WDS089*G5B12A1A	44.9	48.3	50.1	53.1	46.0	49.6	51.4	54.5
WDS107*G6B12A1A	53.8	57.9	60.1	63.7	55.2	59.5	61.7	65.4
WDS125*G7B12A1A	62.8	67.6	70.1	74.3	64.4	69.3	71.9	76.3
DOUBLE FAN-WIDTH MODELS								
WDD043*G2B12A2A	20.4	23.2	25.5	27.5	19.3	21.9	24.1	26.0
WDD059*G2B12A2A	28.7	31.9	34.2	36.2	28.0	31.1	33.4	35.3
WDD067*G2B12A2A	33.0	36.0	38.0	40.1	33.2	36.2	38.2	40.3
WDD089*G3B12A2A	43.2	48.1	51.5	54.5	42.1	46.9	50.3	53.2
WDD102*G3B12A2A	50.7	55.3	58.3	61.6	51.0	55.6	58.7	61.9
WDD118*G4B12A2A	57.5	64.0	68.6	72.6	56.0	62.4	66.9	70.8
WDD135*G4B12A2A	66.9	73.0	77.0	81.3	67.3	73.4	77.4	81.8
WDD147*G5B12A2A	72.2	79.3	84.9	89.0	71.7	78.7	84.3	88.4
WDD179*G5B12A2A	89.8	96.7	100.3	106.4	92.2	99.3	102.9	109.2
WDD214*G6B12A2A	107.7	116.0	120.3	127.6	110.6	119.0	123.4	130.9
WDD250*G7B12A2A	125.6	135.2	140.2	148.8	128.9	138.8	143.9	152.7

*** voltage code place holder**

For R-22 capacity, multiply R404A unit capacity by 1.02
 For R-410A capacity, multiply R404A unit capacity by 1.08
 For R-134 capacity multiply R-404A unit capacity by .97
 For R-407C capacity, multiply R407A capacity by .98

Note:

R-407A Ratings are based on Mean Condensing Temperature which is the average of the Dew Point and Bubble Point temperatures corresponding to the refrigerant temperature at the condenser inlet.

Condensers with Variable Speed Electronically Commutated (VSEC) motors provide quiet and highly efficient condenser operation. While maximum performance is required to meet peak daytime demands, lower speed and lower noise levels characterize off-peak and night time conditions.

Utilizing state of the art programmable VSEC fan motor assemblies, these condensers provide the flexibility to meet these challenging requirements while delivering quiet, energy efficient and trouble free operation.

Remote Air Cooled Condenser

Specifications

Variable Speed EC Fan Motors

Unit Size	Fan				Maximum Circuit Qty	Connections (inches)	Conn Qty	Approximate Net Wgt. (lbs)	Unit kW	208-230/3/60			460/3/60			575/3/60		
	Qty	Dia	CFM	dBA†						FLA	MCA	MOPD	FLA	MCA	MOPD	FLA	MCA	MOPD

SINGLE FAN-WIDTH MODELS

011	1	31.5	12270	59.1	12	1 5/8	2	345	1.44	4.2	15.0	15	2.1	15.0	15	Not Available
015	1	31.5	11390	59.1	18	1 5/8	2	365	1.44	4.2	15.0	15	2.1	15.0	15	
017	1	31.5	10620	59.1	24	1 5/8	2	390	1.44	4.2	15.0	15	2.1	15.0	15	
022	2	31.5	24540	62.0	18	1 5/8	2	630	2.88	8.4	15.0	15	4.2	15.0	15	
030	2	31.5	22780	62.0	27	1 5/8	2	675	2.88	8.4	15.0	15	4.2	15.0	15	
033	2	31.5	21240	62.0	36	1 5/8	2	725	2.88	8.4	15.0	15	4.2	15.0	15	
045	3	31.5	34170	63.7	27	2 1/8	2	980	4.32	12.6	15.0	15	6.3	15.0	15	
051	3	31.5	31860	63.7	36	2 1/8	2	1150	4.32	12.6	15.0	15	6.3	15.0	15	
059	4	31.5	45560	65.0	27	2 1/8	2	1250	5.76	16.8	17.9	20	8.4	15.0	15	
067	4	31.5	42840	65.0	36	2 1/8	2	1350	5.76	16.8	17.9	20	8.4	15.0	15	
073	5	31.5	56950	65.9	27	2 5/8	2	1600	7.20	21.0	22.1	25	10.5	15.0	15	
089	5	31.5	53100	65.9	36	2 5/8	2	1740	7.20	21.0	22.1	25	10.5	15.0	15	
107	6	31.5	63720	66.8	36	2 5/8	2	2050	8.64	25.2	26.3	30	12.6	15.0	15	
125	7	31.5	74340	67.4	36	2 5/8	2	2375	10.08	29.4	30.5	35	14.7	15.2	20	

DOUBLE FAN-WIDTH MODELS

043	4	31.5	49080	67.1	36	1 5/8	4	1115	5.76	16.8	17.9	20	8.4	15.0	15	Not Available
059	4	31.5	45560	67.1	54	1 5/8	4	1210	5.76	16.8	17.9	20	8.4	15.0	15	
067	4	31.5	42480	67.1	72	1 5/8	4	1310	5.76	16.8	17.9	20	8.4	15.0	15	
089	6	31.5	68340	68.8	54	2 1/8	4	1750	8.64	25.2	26.3	30	12.6	15.0	15	
102	6	31.5	63720	68.8	72	2 1/8	4	1900	8.64	25.2	26.3	30	12.6	15.0	15	
118	8	31.5	91120	70.1	54	2 1/8	4	2250	11.52	33.6	34.7	35	16.8	17.3	20	
135	8	31.5	84960	70.1	72	2 1/8	4	2450	11.52	33.6	34.7	35	16.8	17.3	20	
147	10	31.5	113900	71.0	54	2 5/8	4	2890	14.40	42.0	43.1	45	21.0	21.5	25	
179	10	31.5	106200	71.0	72	2 5/8	4	3170	14.40	42.0	43.1	45	21.0	21.5	25	
214	12	31.5	127440	71.6	72	2 5/8	4	3745	17.28	50.4	51.5	60	25.2	25.7	30	
250	14	31.5	148680	72.2	72	2 5/8	4	4340	20.16	58.8	59.9	60	29.4	29.9	30	

†Sound pressure dBA @ 10 feet.

* = Voltage code place holder

Variable Speed EC Fan Motors - Sound Data dBA@ 10 FT.

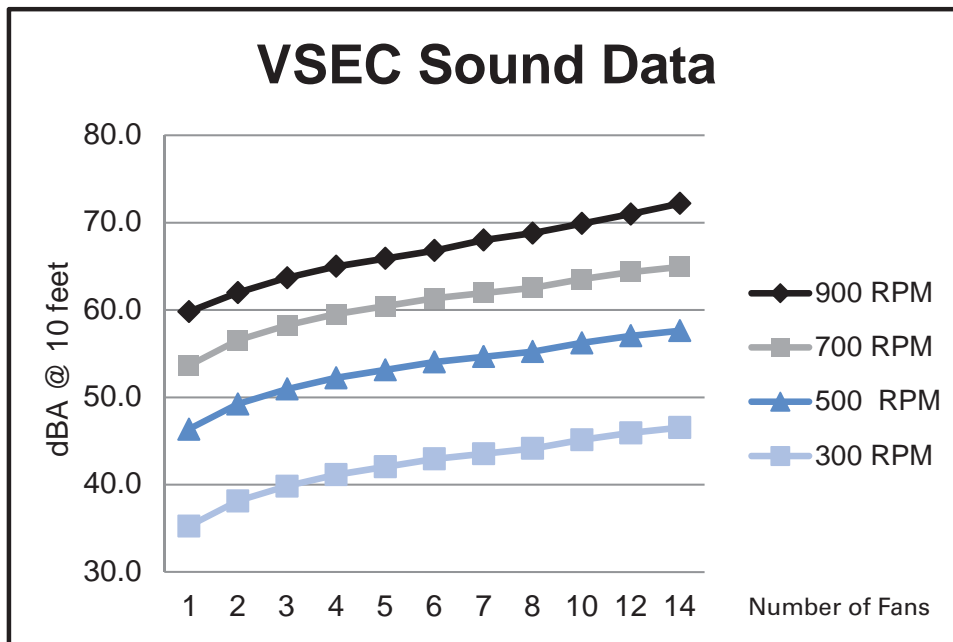

Remote Air Cooled Condenser

Performance Data - THR MBH 1°F TD

1140 RPM Fan Motors

Unit Size	Refrigerants-404A & 507				Refrigerant-407A			
	FPI				FPI			
	8	10	12	14	8	10	12	14
SMALL CONDENSERS								
WDS001*A1B12A1A	0.73	0.84	0.90	1.04	0.67	0.77	0.82	0.95
WDS002*A1B12A1A	1.17	1.33	1.46	1.57	1.11	1.26	1.38	1.48
WDS003*A1B12A1A	1.60	1.81	1.99	2.15	1.52	1.72	1.89	2.04
WDS005*A1B12A1A	2.23	2.48	2.66	2.81	2.18	2.43	2.61	2.75
WDS007*A2B12A1A	3.42	3.89	4.27	4.60	3.25	3.69	4.05	4.37
WDS009*A2B12A1A	4.56	5.08	5.45	5.76	4.47	4.98	5.34	5.64
WDS011*A2B12A1A	5.31	5.79	6.10	6.45	5.37	5.85	6.16	6.52
SINGLE FAN-WIDTH MODELS								
WDS009*B1B12A1A	4.9	5.6	6.1	6.6	4.7	5.3	5.8	6.3
WDS011*B1B12A1A	6.7	7.5	8.0	8.4	6.6	7.3	7.8	8.2
WDS013*B1B12A1A	8.2	8.9	9.3	9.6	8.3	9.0	9.4	9.7
WDS017*B2B12A1A	8.0	9.1	10.0	10.7	7.7	8.7	9.6	10.3
WDS021*B2B12A1A	9.8	11.1	12.2	13.1	9.3	10.5	11.5	12.4
WDS022*B2B12A1A	10.7	11.9	12.7	13.4	10.5	11.6	12.3	13.1
WDS028*B2B12A1A	13.4	14.9	15.9	16.7	13.1	14.5	15.6	16.4
WDS033*B2B12A1A	16.3	17.7	18.6	19.1	16.4	17.8	18.8	19.3
WDS041*B3B12A1A	20.1	22.3	23.9	25.1	19.7	21.8	23.4	24.6
WDS048*B3B12A1A	24.0	26.0	27.4	28.7	24.2	26.3	27.6	29.0
WDS055*B4B12A1A	26.8	29.7	31.8	33.4	26.2	29.1	31.2	32.8
WDS064*B4B12A1A	31.6	34.5	36.4	38.3	31.9	34.8	36.8	38.7
WDS070*B5B12A1A	34.6	38.0	40.5	42.3	34.5	37.9	40.4	42.2
WDS082*B5B12A1A	41.2	44.3	46.4	48.5	42.5	45.7	47.8	50.0
WDS098*B6B12A1A	49.3	53.0	54.3	58.0	50.9	54.7	56.0	59.8
WDS114*B7B12A1A	57.5	61.9	63.4	67.6	59.3	63.8	65.4	69.7
DOUBLE FAN-WIDTH MODELS								
WDD041*B2B12A2A	19.6	22.2	24.3	26.1	18.6	21.1	23.1	24.8
WDD055*B2B12A2A	26.8	29.7	31.8	33.4	26.2	29.1	31.2	32.8
WDD064*B2B12A2A	31.9	34.7	36.4	38.3	32.3	35.0	36.8	38.7
WDD082*B3B12A2A	39.8	44.5	47.3	50.3	39.0	43.6	46.3	49.2
WDD097*B3B12A2A	48.1	52.2	54.8	58.5	48.6	52.7	55.4	59.1
WDD110*B4B12A2A	53.5	59.4	63.7	66.9	52.4	58.2	62.4	65.5
WDD127*B4B12A2A	63.1	68.9	72.9	76.6	63.8	69.7	73.6	77.4
WDD140*B5B12A2A	69.1	75.9	81.0	84.6	69.0	75.7	80.8	84.4
WDD164*B5B12A2A	82.5	88.7	92.8	97.0	85.1	91.5	95.7	100.1
WDD196*B6B12A2A	98.6	106.1	108.7	115.9	101.7	109.4	112.1	119.5
WDD229*B7B12A2A	115.1	123.7	126.8	135.2	118.7	127.6	130.8	139.4

*** voltage code place holder**

For R-22 capacity, multiply R404A unit capacity by 1.02
 For R-410A capacity, multiply R404A unit capacity by 1.08
 For R-134 capacity multiply R-404A unit capacity by .97
 For R-407C capacity, multiply R407A capacity by .98

Note:

R-407A Ratings are based on Mean Condensing Temperature which is the average of the Dew Point and Bubble Point temperatures corresponding to the refrigerant temperature at the condenser inlet.

Remote Air Cooled Condenser

Specifications

1140 RPM Fan Motors

Unit Size	Fan				Maximum Circuit Qty	Conn. (inches)	Conn Qty	Net Wgt. (lbs)	Unit kW	208-230/1/60			208-230/3/60			460/1/60			460/3/60			575/1/60		
	Qty	Dia	CFM	dBA†						FLA	MCA	MOPD	FLA	MCA	MOPD	FLA	MCA	MOPD	FLA	MCA	MOPD	FLA	MCA	MOPD

SMALL CONDENSERS

001	1	18	3020	47.0	5	7/8	2	80	0.28	3.2	15.0	15.0	1.8	15.0	15	1.3	15.0	15	0.9	15.0	15	1.0	15.0	15
002	1	18	2840	47.0	10	7/8	2	86	0.28	3.2	15.0	15.0	1.8	15.0	15	1.3	15.0	15	0.9	15.0	15	1.0	15.0	15
003	1	22	4450	57.0	12	7/8	2	107	0.47	3.2	15.0	15.0	1.8	15.0	15	1.3	15.0	15	0.9	15.0	15	1.0	15.0	15
005	1	22	3900	57.0	18	7/8	2	116	0.47	3.2	15.0	15.0	1.8	15.0	15	1.3	15.0	15	0.9	15.0	15	1.0	15.0	15
007	2	22	8640	60.0	18	1 1/8	2	164	0.94	6.4	15.0	15.0	3.6	15.0	15	2.6	15.0	15	1.8	15.0	15	2.0	15.0	15
009	2	22	7780	60.0	27	1 1/8	2	179	0.94	6.4	15.0	15.0	3.6	15.0	15	2.6	15.0	15	1.8	15.0	15	2.0	15.0	15
011	2	22	7080	60.0	36	1 1/8	2	195	0.94	6.4	15.0	15.0	3.6	15.0	15	2.6	15.0	15	1.8	15.0	15	2.0	15.0	15

SINGLE FAN-WIDTH MODELS

Unit Size	Fan				Maximum Circuit Qty	Conn. (inches)	Conn Qty	Net Wgt. (lbs)	Unit kW	208-230/1/60			208-230/3/60			460/1/60			460/3/60			575/3/60		
	Qty	Dia	CFM	dBA†						FLA	MCA	MOPD	FLA	MCA	MOPD	FLA	MCA	MOPD	FLA	MCA	MOPD	FLA	MCA	MOPD
009	1	30	11400	71.0	12	1 3/8	2	305	1.8	4.7	15.0	20.0	6.5	15.0	20	2.4	15.0	20.0	3.3	15.0	15	2.2	15.0	15
011	1	30	10700	71.0	18	1 3/8	2	330	1.8	4.7	15.0	20.0	6.5	15.0	20	2.4	15.0	20.0	3.3	15.0	15	2.2	15.0	15
013	1	30	10140	71.0	24	1 3/8	2	360	1.8	4.7	15.0	20.0	6.5	15.0	20	2.4	15.0	20.0	3.3	15.0	15	2.2	15.0	15
017	2	30	15500	73.8	18	1 5/8	2	560	2.0	9.4	15.0	20.0	13.0	15.0	20	4.7	15.0	20.0	6.6	15.0	15	4.3	15.0	15
021	2	30	22800	74.1	18	1 5/8	2	575	2.0	---	---	---	13.0	15.0	20	---	---	---	6.6	15.0	15	4.3	15.0	15
022	2	30	15400	73.8	27	1 5/8	2	590	3.6	9.4	15.0	20.0	13.0	15.0	20	4.7	15.0	20.0	6.6	15.0	15	4.3	15.0	15
028	2	30	21400	74.1	27	1 5/8	2	610	3.6	---	---	---	13.0	15.0	20	---	---	---	6.6	15.0	15	4.3	15.0	15
033	2	30	20280	74.1	36	1 5/8	2	660	3.6	---	---	---	13.0	15.0	20	---	---	---	6.6	15.0	15	4.3	15.0	15
041	3	30	32100	75.9	27	2 1/8	2	880	5.4	---	---	---	19.5	21.2	25	---	---	---	9.9	15.0	15	6.5	15.0	15
048	3	30	30420	75.9	36	2 1/8	2	950	5.4	---	---	---	19.5	21.2	25	---	---	---	9.9	15.0	15	6.5	15.0	15
055	4	30	42800	77.3	27	2 1/8	2	1120	7.2	---	---	---	26.0	27.7	30	---	---	---	13.2	15.0	15	8.6	15.0	15
064	4	30	40560	77.3	36	2 5/8	2	1220	7.2	---	---	---	26.0	27.7	30	---	---	---	13.2	15.0	15	8.6	15.0	15
070	5	30	53500	78.0	27	2 5/8	2	1440	9.0	---	---	---	32.5	34.2	40	---	---	---	16.5	17.4	20	10.8	15.0	15
082	5	30	50700	78.0	36	2 5/8	2	1575	9.0	---	---	---	32.5	34.2	40	---	---	---	16.5	17.4	20	10.8	15.0	15
098	6	30	60840	78.8	36	2 5/8	2	1855	10.8	---	---	---	39.0	40.7	45	---	---	---	19.8	20.7	25	12.9	15.0	15
114	7	30	70980	79.2	36	2 5/8	2	2150	12.6	---	---	---	45.5	47.2	50	---	---	---	23.1	24.0	25	15.1	15.6	20

DOUBLE FAN-WIDTH MODELS

041	4	30	45600	77.3	36	1 5/8	4	985	7.2	---	---	---	26.0	27.6	30	---	---	---	13.2	15.0	15	8.6	15.0	15
055	4	30	42800	77.3	54	1 5/8	4	1080	7.2	---	---	---	26.0	27.6	30	---	---	---	13.2	15.0	15	8.6	15.0	15
064	4	30	45600	77.3	72	1 5/8	4	1180	7.2	---	---	---	26.0	27.6	30	---	---	---	13.2	15.0	15	8.6	15.0	15
082	6	30	64200	78.8	54	2 1/8	4	1555	10.8	---	---	---	39.0	40.7	45	---	---	---	19.8	20.7	25	12.9	15.0	15
097	6	30	60840	78.8	72	2 1/8	4	1703	10.8	---	---	---	39.0	40.7	45	---	---	---	19.8	20.7	25	12.9	15.0	15
110	8	30	85600	80.0	54	2 1/8	4	1990	14.4	---	---	---	52.0	53.7	60	---	---	---	26.4	27.3	30	17.2	17.7	20
127	8	30	81120	80.0	72	2 1/8	4	2190	14.4	---	---	---	52.0	53.7	60	---	---	---	26.4	27.3	30	17.2	17.7	20
140	10	30	107000	81.2	54	2 5/8	4	2565	18.0	---	---	---	65.0	66.7	70	---	---	---	33.0	33.9	35	21.5	22.0	25
164	10	30	101400	81.2	72	2 5/8	4	2842	18.0	---	---	---	65.0	66.7	70	---	---	---	33.0	33.9	35	21.5	22.0	25
196	12	30	121680	81.6	72	2 5/8	4	3355	21.6	---	---	---	78.0	79.7	80	---	---	---	39.6	40.5	45	25.8	26.3	30
229	14	30	141960	82.3	72	2 5/8	4	3880	25.2	---	---	---	91.0	92.7	100	---	---	---	46.2	47.1	50	30.1	30.6	35

†Sound pressure dBA @ 10 feet.

Remote Air Cooled Condenser

Performance Data - THR MBH 1°F TD

850 RPM with 0.25 HP Fan Motors

Unit Size	Refrigerants-404A & 507				Refrigerants-R-407A			
	FPI				FPI			
	8	10	12	14	8	10	12	14
SMALL CONDENSERS								
WDS001*C1B12A1A	0.68	0.79	0.88	0.97	0.63	0.73	0.81	0.90
WDS002*C1B12A1A	1.09	1.24	1.36	1.47	1.05	1.19	1.31	1.41
WDS003*C1B12A1A	1.44	1.63	1.79	1.93	1.38	1.57	1.72	1.86
WDS004*C1B12A1A	1.97	2.19	2.35	2.49	1.97	2.19	2.35	2.49
WDS006*C2B12A1A	3.09	3.51	3.86	4.16	2.97	3.37	3.71	4.00
WDS008*C2B12A1A	4.05	4.51	4.83	5.11	4.04	4.50	4.82	5.10
WDS009*C2B12A1A	4.53	4.94	5.21	5.50	4.69	5.12	5.39	5.70

850 RPM with 1-1/2 HP Fan Motors

SINGLE FAN-WIDTH MODELS								
WDS009*D1B12A1A	4.5	5.1	5.6	6.0	4.3	4.9	5.4	5.8
WDS013*D1B12A1A	6.3	7.0	7.2	7.5	6.3	7.0	7.2	7.5
WDS014*D1B12A1A	7.2	7.8	8.2	8.7	7.5	8.1	8.5	9.0
WDS019*D2B12A1A	9.0	10.3	11.2	12.1	8.6	9.8	10.7	11.5
WDS026*D2B12A1A	12.6	13.9	14.3	15.0	12.4	13.7	14.1	14.8
WDS029*D2B12A1A	14.3	15.5	16.3	17.4	14.5	15.8	16.6	17.7
WDS039*D3B12A1A	19.0	21.0	22.0	23.0	18.6	20.7	21.7	22.6
WDS044*D3B12A1A	22.0	23.8	25.0	26.3	22.3	24.2	25.5	25.5
WDS051*D4B12A1A	25.1	27.9	29.0	30.0	24.7	27.4	28.5	29.5
WDS058*D4B12A1A	28.9	31.4	32.1	34.7	29.4	31.9	32.6	35.3
WDS063*D5B12A1A	31.1	34.1	35.9	37.4	31.2	34.2	36.0	37.5
WDS077*D5B12A1A	38.3	41.1	42.8	43.9	39.7	42.7	44.4	45.6
WDS092*D6B12A1A	45.9	49.3	51.5	52.7	47.6	51.2	53.4	54.7
WDS107*D7B12A1A	53.6	57.6	60.1	61.5	55.6	59.7	62.4	63.8

DOUBLE FAN-WIDTH MODELS								
WDD037*D2B12A2A	17.6	20.0	21.9	23.5	16.8	19.0	20.8	22.4
WDD052*D2B12A2A	25.1	27.8	29.0	29.8	24.7	27.4	28.5	29.3
WDD056*D2B12A2A	28.9	30.5	32.0	31.1	29.4	31.0	32.5	31.6
WDD076*D3B12A2A	37.7	41.3	43.5	46.3	37.1	40.7	42.8	45.6
WDD087*D3B12A2A	43.4	47.1	49.5	53.0	44.1	47.9	50.3	53.9
WDD103*D4B12A2A	50.2	55.8	58.0	59.9	49.4	54.9	57.1	59.0
WDD116*D4B12A2A	57.9	62.8	64.2	69.4	58.8	63.9	65.3	70.6
WDD126*D5B12A2A	62.3	68.3	71.9	74.8	62.4	68.4	72.0	75.0
WDD152*D5B12A2A	76.5	82.3	85.7	87.9	79.3	85.3	88.8	91.1
WDD183*D6B12A2A	91.8	98.7	103.1	105.4	95.2	102.3	106.9	109.4
WDD213*D7B12A2A	107.1	115.1	120.3	123.0	111.1	119.4	124.7	127.6

*** voltage code place holder**

For R-22 capacity, multiply R404A unit capacity by 1.02
 For R-410A capacity, multiply R404A unit capacity by 1.08
 For R-134 capacity multiply R-404A unit capacity by .97
 For R-407C capacity, multiply R407A capacity by .98

Note:

R-407A Ratings are based on Mean Condensing Temperature which is the average of the Dew Point and Bubble Point temperatures corresponding to the refrigerant temperature at the condenser inlet.

Remote Air Cooled Condenser

Specifications

850 RPM with 0.25 HP Fan Motors

Unit Size	Fan				Maximum Circuit Qty	Conn (inches)	Conn Qty	Net Wgt. (lbs)	Unit kW	208-230/1/60			208-230/3/60			460/1/60			460/3/60			575/1/60					
	Qty	Dia	CFM	dBA†						FLA	MCA	MOPD	FLA	MCA	MOPD	FLA	MCA	MOPD	FLA	MCA	MOPD	FLA	MCA	MOPD	FLA	MCA	MOPD
	SINGLE FAN-WIDTH MODELS																										
001	1	18	2470	44.0	5	7/8	2	80	0.11	1.4	15.0	15.0	1.1	15.0	15	0.7	15.0	15	0.6	15.0	15	Not Available					
002	1	18	2110	44.0	10	7/8	2	86	0.11	1.4	15.0	15.0	1.1	15.0	15	0.7	15.0	15	0.6	15.0	15						
003	1	22	3290	52.0	12	7/8	2	107	0.20	1.4	15.0	15.0	1.1	15.0	15	0.7	15.0	15	0.6	15.0	15						
004	1	22	2880	52.0	18	7/8	2	116	0.20	1.4	15.0	15.0	1.1	15.0	15	0.7	15.0	15	0.6	15.0	15						
006	2	22	6390	55.0	18	1 1/8	2	164	0.40	2.8	15.0	15.0	2.2	15.0	15	1.4	15.0	15	1.2	15.0	15						
008	2	22	5760	55.0	27	1 1/8	2	179	0.40	2.8	15.0	15.0	2.2	15.0	15	1.4	15.0	15	1.2	15.0	15						
009	2	22	5170	55.0	36	1 1/8	2	195	0.40	2.8	15.0	15.0	2.2	15.0	15	1.4	15.0	15	1.2	15.0	15						

850 RPM with 1-1/2 HP Fan Motors

Unit Size	Fan				Maximum Circuit Qty	Conn (inches)	Conn Qty	Net Wgt. (lbs)	Unit kW	208-230/1/60			208-230/3/60			460/1/60			460/3/60			575/3/60					
	Qty	Dia	CFM	dBA†						FLA	MCA	MOPD	FLA	MCA	MOPD	FLA	MCA	MOPD	FLA	MCA	MOPD	FLA	MCA	MOPD	FLA	MCA	MOPD
	SINGLE FAN-WIDTH MODELS																										
009	1	30	10690	66.9	12	1 3/8	2	305	1.45	Not Available			6.5	15.0	15	Not Available			3.3	15.0	15	Not Available					
013	1	30	9960	66.9	18	1 3/8	2	330	1.45				6.5	15.0	15				3.3	15.0	15						
014	1	30	9300	66.9	24	1 3/8	2	360	1.45				6.5	15.0	15				3.3	15.0	15						
019	2	30	21380	69.8	18	1 5/8	2	590	2.90				13.0	15.0	20				6.6	15.0	15						
026	2	30	19920	69.8	27	1 5/8	2	610	2.90				13.0	15.0	20				6.6	15.0	15						
029	2	30	18600	69.8	36	1 5/8	2	660	2.90				13.0	15.0	20				6.6	15.0	15						
039	3	30	29880	71.8	27	2 1/8	2	880	4.35				19.5	21.2	25				9.9	15.0	15						
044	3	30	27900	71.8	36	2 1/8	2	950	4.35				19.5	21.2	25				9.9	15.0	15						
051	4	30	39840	73.1	27	2 1/8	2	1120	5.80				26.0	27.7	30				13.2	15.0	15						
058	4	30	37200	73.1	36	2 5/8	2	1220	5.80	26.0	27.7	30	13.2	15.0	15												
063	5	30	49800	74.2	27	2 5/8	2	1440	7.25	32.5	34.2	40	16.5	17.4	20												
077	5	30	46500	74.2	36	2 5/8	2	1575	7.25	32.5	34.2	40	16.5	17.4	20												
092	6	30	55800	74.8	36	2 5/8	2	1855	8.70	39.0	40.7	45	19.8	20.7	25												
107	7	30	65100	75.0	36	2 5/8	2	2150	10.15	45.5	47.2	50	23.1	24.0	25												

DOUBLE FAN-WIDTH MODELS																								
Unit Size	Qty	Dia	CFM	dBA†	Maximum Circuit Qty	Conn (inches)	Conn Qty	Net Wgt. (lbs)	Unit kW	208-230/1/60			208-230/3/60			460/1/60			460/3/60			575/3/60		
										FLA	MCA	MOPD	FLA	MCA	MOPD	FLA	MCA	MOPD	FLA	MCA	MOPD	FLA	MCA	MOPD
037	4	30	42760	73.1	36	1 5/8	4	985	5.80	Not Available			26.0	27.6	30	Not Available			13.2	15.0	15	Not Available		
052	4	30	39840	73.1	54	1 5/8	4	1080	5.80				26.0	27.6	30				13.2	15.0	15			
056	4	30	37200	73.1	72	1 5/8	4	1180	5.80				26.0	27.6	30				13.2	15.0	15			
076	6	30	59760	74.8	54	2 1/8	4	1555	8.70				39.0	40.7	45				19.8	20.7	25			
087	6	30	55800	74.8	72	2 1/8	4	1703	8.70				39.0	40.7	45				19.8	20.7	25			
103	8	30	79680	76.0	54	2 1/8	4	1990	11.60				52.0	53.7	60				26.4	27.3	30			
116	8	30	74400	76.0	72	2 1/8	4	2190	11.60				52.0	53.7	60				26.4	27.3	30			
126	10	30	99600	76.9	54	2 5/8	4	2565	14.50				65.0	66.7	70				33.0	33.9	35			
152	10	30	93000	76.9	72	2 5/8	4	2842	14.50				65.0	66.7	70				33.0	33.9	35			
183	12	30	111600	77.3	72	2 5/8	4	3355	17.40	78.0	79.7	80	39.6	40.5	45									
213	14	30	130200	77.9	72	2 5/8	4	3880	20.30	91.0	92.7	100	46.2	47.1	50									

†Sound pressure dBA @ 10 feet.

Remote Air Cooled Condenser

Performance Data - THR MBH 1°F TD

850 RPM with 1 HP Fan Motors

Unit Size	Refrigerants-404A & 507			
	FPI			
	8	10	12	14

Refrigerant-407A				
FPI				
	8	10	12	14

SINGLE FAN-WIDTH MODELS

WDS008*L1B12A1A	4.0	4.5	4.9	5.2
WDS011*L1B12A1A	5.4	6.0	6.3	6.5
WDS013*L1B12A1A	6.6	7.1	7.4	7.7
WDS014*L2B12A1A	6.6	7.5	8.2	8.8
WDS017*L2B12A1A	8.0	9.0	9.8	10.4
WDS018*L2B12A1A	8.7	9.6	10.3	10.9
WDS022*L2B12A1A	10.8	11.9	12.5	13.0
WDS026*L2B12A1A	13.3	14.3	14.8	15.5
WDS035*L3B12A1A	17.1	18.8	19.7	20.5
WDS040*L3B12A1A	20.0	21.4	22.3	23.2
WDS046*L4B12A1A	22.7	25.1	26.3	27.3
WDS053*L4B12A1A	26.6	28.5	29.6	30.9
WDS056*L5B12A1A	27.8	30.4	31.9	33.2
WDS069*L5B12A1A	35.0	37.4	38.6	39.7
WDS083*L6B12A1A	42.0	44.9	46.4	47.6
WDS097*L7B12A1A	48.9	52.4	54.1	55.5

	3.8	4.3	4.7	5.0
	5.4	6.0	6.3	6.5
	6.9	7.4	7.7	8.0
	6.3	7.2	7.9	8.5
	7.6	8.7	9.4	10.0
	8.7	9.6	10.3	10.9
	10.8	11.9	12.5	13.0
	13.8	14.8	15.3	16.0
	17.0	18.8	19.7	20.5
	20.7	22.2	23.1	24.1
	22.7	25.0	26.3	27.3
	27.5	29.5	30.7	32.0
	28.3	31.0	32.5	33.7
	36.9	39.5	40.8	41.9
	44.3	47.4	49.0	50.3
	51.7	55.3	57.1	58.7

DOUBLE FAN-WIDTH MODELS

WDD033*L2B12A2A	15.7	17.7	19.2	20.6
WDD046*L2B12A2A	22.7	25.1	26.3	27.3
WDD053*L2B12A2A	26.6	28.5	29.6	30.9
WDD070*L3B12A2A	34.1	37.6	39.5	41.0
WDD081*L3B12A2A	40.8	43.8	45.5	47.4
WDD093*L4B12A2A	45.5	50.1	52.7	54.7
WDD106*L4B12A2A	53.2	57.1	59.3	61.8
WDD112*L5B12A2A	55.5	60.8	63.9	66.3
WDD138*L5B12A2A	69.9	74.9	77.3	79.4
WDD166*L6B12A2A	83.9	89.8	92.7	95.2
WDD194*L7B12A2A	97.9	104.8	108.2	111.1

	15.1	17.0	18.5	19.8
	22.7	25.0	26.3	27.3
	27.5	29.5	30.7	32.0
	34.1	37.5	39.4	40.9
	42.2	45.3	47.1	49.1
	45.4	50.0	52.6	54.6
	55.1	59.1	61.4	64.0
	56.5	61.9	65.0	67.5
	73.8	79.1	81.6	83.8
	88.6	94.9	97.9	100.5
	103.4	110.7	114.2	117.3

*** voltage code place holder**

For R-22 capacity, multiply R404A unit capacity by 1.02
 For R-410A capacity, multiply R404A unit capacity by 1.08
 For R-134 capacity multiply R-404A unit capacity by .97
 For R-407C capacity, multiply R407A capacity by .98

Note:

R-407A Ratings are based on Mean Condensing Temperature which is the average of the Dew Point and Bubble Point temperatures corresponding to the refrigerant temperature at the condenser inlet.

Remote Air Cooled Condenser

Specifications

850 RPM with 1 HP Fan Motors

Unit Size	Fan				Maximum Circuit Qty.	Conn. (inches)	Conn Qty	Net Wgt. (lbs)	Unit kW	208-230/3/60			460/3/60			575/3/60		
	Qty	Dia	CFM	dBA†						FLA	MCA	MOPD	FLA	MCA	MOPD	FLA	MCA	MOPD
SINGLE FAN-WIDTH MODELS																		
008	1	30	8490	65.0	12	1 3/8	2	300	0.9	4.0	15.0	15	2.0	15.0	15	2.1	15.0	15
011	1	30	7910	65.0	18	1 3/8	2	325	0.9	4.0	15.0	15	2.0	15.0	15	2.1	15.0	15
013	1	30	7470	65.0	24	1 3/8	2	355	0.9	4.0	15.0	15	2.0	15.0	15	2.1	15.0	15
014	2	30	11700	66.5	18	1 5/8	2	550	1.4	8.0	15.0	15	4.0	15.0	15	4.2	15.0	15
017	2	30	16980	68.0	18	1 5/8	2	550	1.8	8.0	15.0	15	4.0	15.0	15	4.2	15.0	15
018	2	30	11500	66.5	27	1 5/8	2	600	1.4	8.0	15.0	15	4.0	15.0	15	4.2	15.0	15
022	2	30	15820	68.0	27	1 5/8	2	600	1.8	8.0	15.0	15	4.0	15.0	15	4.2	15.0	15
026	2	30	14940	68.0	36	1 5/8	2	650	1.8	8.0	15.0	15	4.0	15.0	15	4.2	15.0	15
035	3	30	23730	69.8	27	2 1/8	2	860	2.7	12.0	15.0	15	6.0	15.0	15	6.3	15.0	15
040	3	30	22410	69.8	36	2 1/8	2	930	2.7	12.0	15.0	15	6.0	15.0	15	6.3	15.0	15
046	4	30	31640	71.0	27	2 1/8	2	1090	3.6	16.0	17.0	20	8.0	15.0	15	8.4	15.0	15
053	4	30	29880	71.0	36	2 5/8	2	1190	3.6	16.0	17.0	20	8.0	15.0	15	8.4	15.0	15
056	5	30	39550	72.0	27	2 5/8	2	1405	4.5	20.0	21.0	25	10.0	15.0	15	10.5	15.0	15
069	5	30	37350	72.0	36	2 5/8	2	1540	4.5	20.0	21.0	25	10.0	15.0	15	10.5	15.0	15
083	6	30	44820	72.8	36	2 5/8	2	1815	5.4	24.0	25.0	25	12.0	15.0	15	12.6	15.0	15
097	7	30	52290	73.4	36	2 5/8	2	2100	6.3	28.0	29.0	30	14.0	15.0	15	14.7	15.2	20

DOUBLE FAN-WIDTH MODELS																		
033	4	30	33960	71.0	36	1 5/8	4	955	3.6	16.0	17.0	20	8.0	15.0	15	8.4	15.0	15
046	4	30	31640	71.0	54	1 5/8	4	1050	3.6	16.0	17.0	20	8.0	15.0	15	8.4	15.0	15
053	4	30	29880	71.0	72	1 5/8	4	1150	3.6	16.0	17.0	20	8.0	15.0	15	8.4	15.0	15
070	6	30	47460	72.8	54	2 1/8	4	1515	5.4	24.0	25.0	25	12.0	15.0	15	12.6	15.0	15
081	6	30	44820	72.8	72	2 1/8	4	1660	5.4	24.0	25.0	25	12.0	15.0	15	12.6	15.0	15
093	8	30	63280	74.0	54	2 1/8	4	1935	7.2	32.0	33.0	35	16.0	16.5	20	16.8	17.3	20
106	8	30	59760	74.0	72	2 1/8	4	2135	7.2	32.0	33.0	35	16.0	16.5	20	16.8	17.3	20
112	10	30	79100	75.0	54	2 5/8	4	2495	9.0	40.0	41.0	45	20.0	20.5	25	21.0	21.5	25
138	10	30	74700	75.0	72	2 5/8	4	2770	9.0	40.0	41.0	45	20.0	20.5	25	21.0	21.5	25
166	12	30	89640	75.8	72	2 5/8	4	3270	10.8	48.0	49.0	50	24.0	24.5	25	25.2	25.7	30
194	14	30	104580	76.4	72	2 5/8	4	3780	12.6	56.0	57.0	60	28.0	28.5	30	29.4	29.9	30

†Sound pressure dBA @ 10 feet.

Remote Air Cooled Condenser

Performance Data - THR MBH 1°F TD

550 RPM Fan Motors

Unit Size	Refrigerants-404A & 507				Refrigerant-407A			
	FPI				FPI			
	8	10	12	14	8	10	12	14
SINGLE FAN-WIDTH MODELS								
WDS008*E1B12A1A	3.7	4.1	4.5	4.7	3.6	4.0	4.4	4.6
WDS010*E1B12A1A	4.8	5.3	5.5	5.6	4.9	5.4	5.6	5.7
WDS011*E1B12A1A	5.5	5.8	6.0	6.2	5.9	6.2	6.4	6.6
WDS015*E2B12A1A	7.3	8.2	8.9	9.4	7.1	8.1	8.7	9.2
WDS019*E2B12A1A	9.5	10.5	11.0	11.2	9.7	10.7	11.3	11.5
WDS021*E2B12A1A	10.9	11.5	11.9	12.4	11.6	12.3	12.6	13.2
WDS029*E3B12A1A	14.6	15.8	16.6	17.1	15.0	16.2	16.9	17.5
WDS032*E3B12A1A	16.5	17.3	18.1	18.2	17.5	18.4	19.2	19.4
WDS039*E4B12A1A	19.3	20.9	22.0	22.5	19.8	21.4	22.5	23.1
WDS043*E4B12A1A	21.8	23.3	23.6	24.8	23.2	24.8	25.2	26.4
WDS049*E5B12A1A	24.3	26.6	27.5	28.4	25.4	27.7	28.7	29.6
WDS054*E5B12A1A	27.6	29.1	30.2	30.6	30.0	31.6	32.8	33.2
WDS068*E6B12A1A	34.3	36.7	37.0	37.5	37.3	39.9	40.3	40.7
WDS079*E7B12A1A	40.0	42.7	43.2	43.7	43.5	46.4	46.9	47.5
DOUBLE FAN-WIDTH MODELS								
WDD030*E2B12A2A	14.5	16.3	17.7	18.8	14.2	16.0	17.4	18.4
WDD039*E2B12A2A	18.9	20.9	22.0	22.5	19.4	21.4	22.5	23.1
WDD043*E2B12A2A	21.8	23.1	23.8	24.8	23.2	24.6	25.4	26.4
WDD058*E3B12A2A	29.2	31.5	33.2	34.1	29.9	32.3	34.0	34.9
WDD064*E3B12A2A	32.9	34.5	36.1	36.3	35.1	36.8	38.5	38.7
WDD077*E4B12A2A	38.8	41.8	44.0	45.0	39.7	42.8	45.0	46.0
WDD086*E4B12A2A	43.6	46.5	47.1	49.6	46.5	49.5	50.2	52.8
WDD098*E5B12A2A	48.6	53.0	55.1	56.7	50.6	55.3	57.5	59.1
WDD108*E5B12A2A	55.2	58.2	60.3	61.3	60.1	63.3	65.6	66.6
WDD136*E6B12A2A	68.7	73.5	74.1	74.9	74.7	79.8	80.5	81.5
WDD158*E7B12A2A	80.0	85.3	86.4	87.4	87.0	92.7	93.9	95.0

*** voltage code place holder**

For R-22 capacity, multiply R404A unit capacity by 1.02
 For R-410A capacity, multiply R404A unit capacity by 1.08
 For R-134 capacity multiply R-404A unit capacity by .97
 For R-407C capacity, multiply R407A capacity by .98

Note:

R-407A Ratings are based on Mean Condensing Temperature which is the average of the Dew Point and Bubble Point temperatures corresponding to the refrigerant temperature at the condenser inlet.

Remote Air Cooled Condenser

Specifications

550 RPM Fan Motors

Unit Size	Fan				Maximum Circuit Qty	Connections (inches)	Conn Qty	Approximate Net Wgt. (lbs)	Unit kW	208-230/3/60			460/3/60			575/3/60		
	Qty	Dia	CFM	dBA†						FLA	MCA	MOPD	FLA	MCA	MOPD	FLA	MCA	MOPD

SINGLE FAN-WIDTH MODELS

008	1	30.0	5840	58.0	12	1 3/8	2	305	0.35	2.8	15.0	15	1.4	15.0	15	Not Available
010	1	30.0	5490	58.0	18	1 3/8	2	330	0.35	2.8	15.0	15	1.4	15.0	15	
011	1	30.0	5180	58.0	24	1 3/8	2	360	0.35	2.8	15.0	15	1.4	15.0	15	
015	2	30.0	11680	60.8	18	1 5/8	2	560	0.70	5.6	15.0	15	2.8	15.0	15	
019	2	30.0	10980	60.8	27	1 5/8	2	610	0.70	5.6	15.0	15	2.8	15.0	15	
021	2	30.0	10360	60.8	36	1 5/8	2	660	0.70	5.6	15.0	15	2.8	15.0	15	
029	3	30.0	16470	62.7	27	2 1/8	2	880	1.05	8.4	15.0	15	4.2	15.0	15	
032	3	30.0	15540	62.7	36	2 1/8	2	950	1.05	8.4	15.0	15	4.2	15.0	15	
039	4	30.0	21960	63.5	27	2 1/8	2	1120	1.40	11.2	15.0	15	5.6	15.0	15	
043	4	30.0	20720	63.5	36	2 1/8	2	1220	1.40	11.2	15.0	15	5.6	15.0	15	
049	5	30.0	27450	63.4	27	2 5/8	2	1435	1.75	14.0	15.0	15	7.0	15.0	15	
054	5	30.0	25900	64.3	36	2 5/8	2	1575	1.75	14.0	15.0	15	7.0	15.0	15	
068	6	30.0	31080	64.8	36	2 5/8	2	1855	2.10	16.8	17.5	20	8.4	15.0	15	
079	7	30.0	36260	65.1	36	2 5/8	2	2150	2.45	19.6	20.3	25	9.8	15.0	15	

DOUBLE FAN-WIDTH MODELS

030	4	30.0	23360	63.5	36	1 5/8	4	985	1.40	11.2	15.0	15	5.6	15.0	15	Not Available
039	4	30.0	21960	63.5	54	1 5/8	4	1080	1.40	11.2	15.0	15	5.6	15.0	15	
043	4	30.0	20720	63.5	72	1 5/8	4	1180	1.40	11.2	15.0	15	5.6	15.0	15	
058	6	30.0	32940	64.8	54	2 1/8	4	1555	2.10	16.8	17.5	20	8.4	15.0	15	
064	6	30.0	31080	64.8	72	2 1/8	4	1705	2.10	16.8	17.5	25	8.4	15.0	15	
077	8	30.0	43920	65.3	54	2 1/8	4	1990	2.80	22.4	23.1	25	11.2	15.0	15	
086	8	30.0	41440	65.3	72	2 1/8	4	2190	2.80	22.4	23.1	25	11.2	15.0	15	
098	10	30.0	54900	66.1	54	2 5/8	4	2565	3.50	28.0	28.7	30	14.0	15.0	15	
108	10	30.0	51800	66.1	72	2 5/8	4	2840	3.50	28.0	28.7	30	14.0	15.0	15	
136	12	30.0	62160	66.8	72	2 5/8	4	3355	4.20	33.6	34.3	35	16.8	20.0	20	
158	14	30.0	72520	67.3	72	2 5/8	4	3880	4.90	39.2	39.9	40	19.6	20.0	20	

†Sound pressure dBA @ 10 feet.

Remote Air Cooled Condenser

Small Condensers

RDS	Drawing	A	B	C	D	E	F	
WDS001*A1	WDS001*C1	1	12 1/2	28	25 9/16	13 3/4	26 5/8	26 13/16
WDS002*A1	WDS002*C1	1	12 1/2	28	25 9/16	13 3/4	26 5/8	26 13/16
WDS003*A1	WDS003*C1	1	14 3/8	33	30 9/16	15 5/8	31 5/8	31 13/16
WDS005*A1	WDS004*C1	1	14 3/8	33	30 9/16	15 5/8	31 5/8	31 13/16
WDS007*A2	WDS006*C2	2	14 3/8	66	30 9/16	15 5/8	64 5/8	31 13/16
WDS009*A2	WDS008*C2	2	14 3/8	66	30 9/16	15 5/8	64 5/8	31 13/16
WDS011*A2	WDS009*C2	2	14 3/8	66	30 9/16	15 5/8	64 5/8	31 13/16

DRAWING - 1 FAN

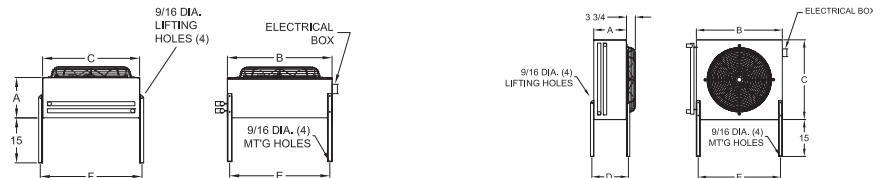

DRAWING - 2 FAN

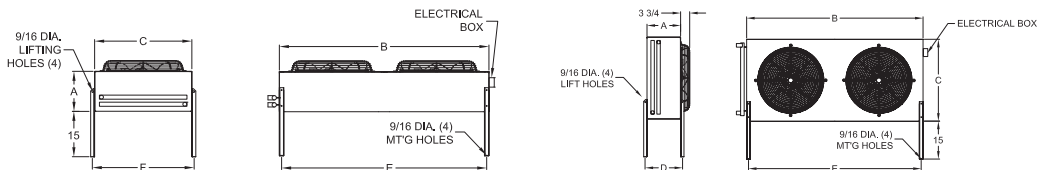

Large Condensers

Condenser Length

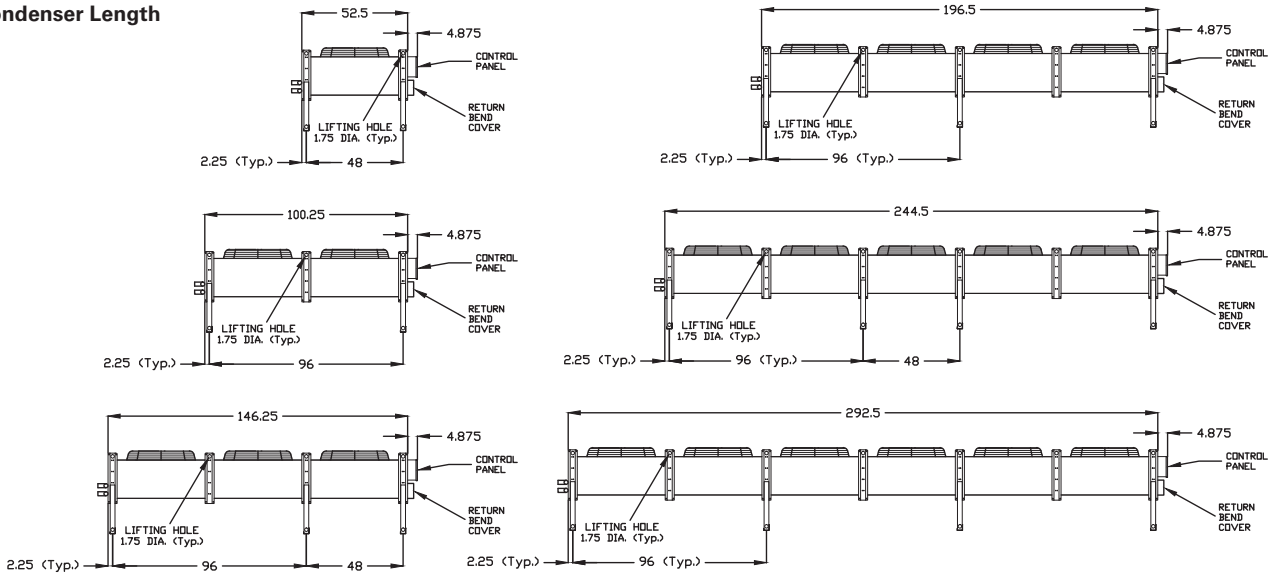

Condenser Width

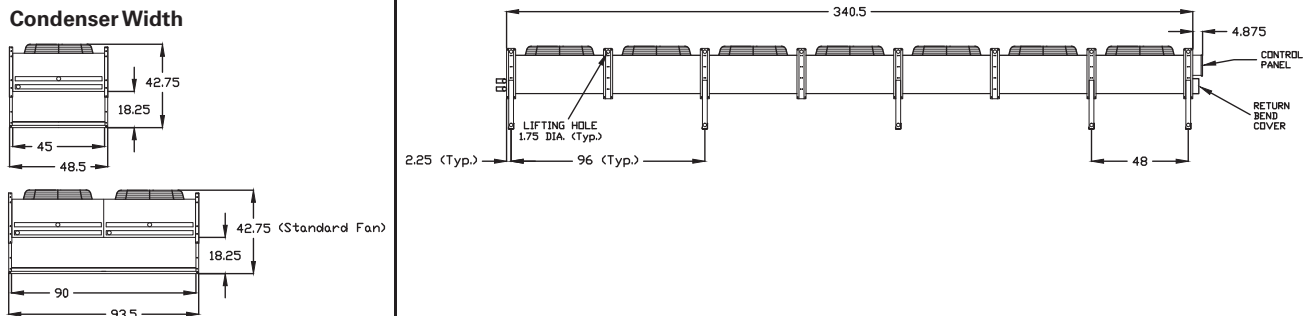

For models *D*****E or *D*****F, height is 46.25

For models *D*****G, height is 50.75

Due to continuing product development, specifications are subject to change without notice.



Witt

201 Thomas French Drive, Scottsboro, AL 35769 PHONE (256) 259-7400 FAX (256) 259-7478 witt.htpgusa.com