



KCC/KEC AIR-COOLED CONDENSERS

DIRECT DRIVE UNICON®

SUBMITTAL
U-859B
February 1995
SUPERCEDES
June 1993



Description:

In this catalog are the advances of more than half a century of pioneering by Kramer in air-cooled condensers. With the advent of environmentally friendlier refrigerants Kramer is again leading the industry in supplying equipment designed to operate at optimum performance. The large air-cooled condenser, now the accepted standard, is more than an assemblage of fans and coil. It is a highly engineered element of the refrigeration system. The reliability of the system depends as much on the performance of the condenser as on the performance of the compressor. Successful UNICON® installations totaling tens of thousands of tons are now giving waterless, economical year-around performance throughout the world. For the utmost in reliability, long life and maintenance-free performance under all conditions Kramer UNICON® stands unmatched.

Features:

- Direct drive arrangement.
- Vertical air flow.
- "KCC" series uses 1140 RPM motors, for high performance.
- "KEC" series uses 850 RPM motors, for quieter operation.
- All motors have inherent thermal overload protection.
- Copper tube, Aluminum finned cores.
- Leak tested at 405 PSIG.
- Factory balanced, heavy duty aluminum fans with steel spiders.
- Epoxy coated heavy gauge steel fan guards for minimum vibration and long life.
- Heavy gauge galvanized steel construction for superior corrosion resistance.
- Custom circuited for optimum performance based on actual application requirements.
- UL and C-UL Listed.

Options:

- Fan cycling head pressure control.
- Flooded head pressure control.
- Combination fan cycling and flooded head pressure control.
- Solid state fan cycling energy management head pressure control.
- Sub-cooling circuit.
- Multi-circuiting.
- Copper fins.
- Epoxy coated fins.
- Baked Phenolic coatings.
- Built-in disconnect switch.
- Individual motor fusing.
- Flip top access.

SELECTIONS

For the proper selection of an air-cooled condenser it is necessary to know the total heat rejection of the condenser. The Total Heat Rejection (THR) is equivalent to the sum of the Net Refrigerating Effect (NRE) plus the heat of compression added by the compressor. The amount of heat added to the refrigerant will depend on the style of compressor, open or suction cooled, and the operating conditions of the system.

Whenever the THR values are available from the compressor manufacturer they should be used in selecting a condenser.

For those cases in which the THR data is unavailable it can be quickly estimated using the following equation and the appropriate factor from Tables 1 or 2.

Eq. (1) THR = Compressor Capacity x Heat Rejection Factor

In those cases where the refrigeration system is of a multiple or cascade style, the following equations should be used to estimate the total heat rejection.

Open Compressor

Eq. (2) THR = Compressor Capacity + (2545 x BHP)

Suction Cooled Compressor

Eq. (3) THR = Compressor Capacity + (3413 x KW)

Altitude at which a condenser is to operate will also affect its capacity. In order to correctly select a condenser at a specific altitude, use the following equation and the appropriate correction factor from Table 3.

Eq. (4) THR Corr. = THR Design x Altitude Correction Factor

Selection Example

- Altitude2000ft.
- Ambient Temperature 95°F
- Evaporator Temperature -10°F
- Maximum Condensing Temperature 105°F
- Refrigerant R-22
- Compressor Capacity (NRE)..... 185,000 BTUH
- Compressor Type..... Suction Cooled

Solution:

1. Calculate the system THR from Table 2, a suction cooled compressor, at 105°F condensing temperature and -10°F evaporator temperature, will have a heat rejection factor of 1.48.

THR = Compressor Capacity x Heat Rejection Factor

THR = 273,800

THR = Corrected Altitude = THR x Altitude Corr. Factor

THR = Corrected Altitude = 288,000 BTUH

2. Design TD = Condensing Temp. - Ambient Temp.

Design TD = 10°F

3. Select condenser size:

From Table 4 at 10°TD select a condenser whose THR equals or exceeds that of which we calculated in Step 1, 288,000 BTUH.

A model KCC 755 with a THR of 300,800 BTUH will meet the required conditions.

4. Eq. (5) Actual TD = $\frac{\text{Design TD} \times \text{Design THR}}{\text{Actual Condenser Capacity at Design TD}}$

Actual TD = 9.6°F

5. Eq. (6) Actual Condensing Temp. = Actual TD + Ambient Temp.

Actual Condensing Temp. = 104.6°F

HEAT OF REJECTION FACTORS

TABLE 1 - OPEN COMPRESSOR

EVAP TEMP.	CONDENSING TEMPERATURE							
	90°	100°	105°	110°	115°	120°	125°	130°
-40°	.45	1.48	1.52	1.56	1.58	1.61		
-35°	.42	1.45	1.47	1.51	1.54	1.57		
-30°	.39	1.41	1.44	1.47	1.50	1.53		
-25°	.37	1.39	1.41	1.44	1.46	1.49	1.52	
-20°	.34	1.37	1.39	1.41	.43	1.45	1.48	1.51
-15°	.31	1.34	1.37	1.38	.40	1.42	1.45	1.47
-10°	1.28	1.31	1.33	1.37	.38	1.40	1.42	1.45
0°	1.24	1.28	1.29	1.32	.33	1.35	1.38	1.41
10°	1.21	1.24	1.26	1.28	.30	1.31	1.34	1.36
20°	1.18	1.21	1.23	1.24	.26	1.28	1.30	1.32
30°	1.15	1.18	1.20	1.21	1.23	1.24	1.26	1.28
40°	1.13	1.15	1.17	1.18	1.19	1.20	1.22	1.24
50°	1.11	1.13	1.14	1.15	1.16	1.17	1.18	1.20

TABLE 2 • SUCTION COOLED COMPRESSOR

EVAP TEMP.	CONDENSING TEMPERATURE							
	90°	100°	105°	110°	115°	120°	125°	130°
-40°	1.67	1.71	1.75	1.79	1.84	1.90		
-35°	1.63	1.67	1.70	1.73	1.78	1.83		
-30°	1.58	1.62	1.65	1.68	1.72	1.77		
-25°	1.54	1.58	1.60	1.64	1.67	1.71	1.76	
-20°	1.49	1.53	1.56	1.58	1.63	1.66	1.70	1.75
-15°	1.46	1.50	1.52	1.54	1.58	1.62	1.65	1.69
-10°	1.42	1.46	1.48	1.50	1.53	1.57	1.62	1.64
0°	1.36	1.40	1.42	1.44	1.47	1.50	1.54	1.56
10°	1.31	1.34	1.36	1.38	1.40	1.43	1.47	1.49
20°	1.26	1.29	1.31	1.33	1.35	1.37	1.40	1.43
30°	1.22	1.25	1.26	1.28	1.30	1.32	1.35	1.37
40°	1.18	1.24	1.22	1.24	1.25	1.27	1.30	1.32
50°	1.14	1.17	1.18	1.20	1.21	1.23	1.25	1.27

TABLE 3 - ALTITUDE CORRECTION FACTOR (FT)

ALTITUDE	SEA LEVEL	1000	2000	3000	4000	5000	6000	7000	8000	9000	10000
FACTOR	1.0	1.029	1.052	1.076	1.101	1.125	1.151	1.177	1.204	1.231	1.260

PERFORMANCE AND ELECTRICAL DATA

TABLE 4 • "KCC" MODELS (1140 RPM MOTORS)

MODEL NUMBER	CAPACITY (HEAT OF REJECTION) (Btu/hr, R-22) (1)					CFM	FAN DATA			MOTOR		ELECTRICAL	
	1 TD	10 TD	15 TD	20 TD	30 TD		ARRG'T	QTY	DIAM. (in)	HP	RPM	AMPS 230/3 V.	AMPS 460/3 V.
KCC 295	11,720	117,200	175,800	234,400	351,600	23800	1x2	2	30	1-1/2	1140	12.8	6.4
KCC 335	13,290	132,900	199,350	265,800	398,700	24200							
KCC 375	15,040	150,400	225,600	300,800	451,200	24100							
KCC 425	16,950	169,500	254,250	339,000	508,500	24050							
KCC 495	19,940	199,400	299,100	398,800	598,200	36300	3x1	3					
KCC 525	21,050	210,500	315,750	421,000	631,500	35100							
KCC 635	25,420	254,200	381,300	508,400	762,600	36075	4x1	4					
KCC 665	26,580	265,800	398,700	531,600	797,400	48400							
KCC 755	30,080	300,800	451,200	601,600	902,400	48200							
KCC 765	30,680	306,800	460,200	613,600	920,400	46400	2x2	4					
KCC 835	33,560	335,600	503,400	671,200	1,006,800	48100							
KCC 845	33,900	339,000	508,500	678,000	1,017,000	48100	1 x4						
KCC 995	39,750	397,500	596,250	795,000	1,192,500	58000	1x5	5					
KCC 1005	39,960	399,600	599,400	799,200	1,198,800	70200	2x3	6					
KCC 1085	43,580	435,800	653,700	871,600	1,307,400	72300							
KCC 1255	50,340	503,400	755,100	1,006,800	1,510,200	72150							
KCC 1335	53,280	532,800	799,200	1,065,600	1,598,400	93600	2x4	8					
KCC 1455	58,100	581,000	871,500	1,162,000	1,743,000	96400							
KCC 1535	61,350	613,500	920,250	1,227,000	1,840,500	92800							
KCC 1675	67,120	671,200	1,006,800	1,342,400	2,013,600	96200							
KCC 1815	72,630	726,300	1,089,450	1,452,600	2,178,900	120500	2x5	10					
KCC 2095	83,900	839,000	1,258,500	1,678,000	2,517,000	113000							
KCC 2115	84,500	845,000	1,267,500	1,690,000	2,535,000	120500							
KCC 2235	89,250	892,500	1,338,750	1,785,000	2,677,500	116000							
KCC 2285	91,360	913,600	1,370,400	1,827,200	2,740,800	146400	2x6	12					
KCC 2535	101,400	1,014,000	1,521,000	2,028,000	3,042,000	144600							
KCC 2685	107,120	1,071,200	1,606,800	2,142,400	3,213,600	139200							

TABLE 4A - "KEC" MODELS (850 RPM MOTORS)

KEC 254	10,250	102,500	153,750	205,000	307,500	17600	1 x2	2	30	1	850	10.6	5.3
KEC 294	11,630	116,300	174,450	232,600	348,900	17900							
KEC 334	13,160	131,600	197,400	263,200	394,800	17800							
KEC 374	14,830	148,300	222,450	296,600	444,900	17800							
KEC 434	17,450	174,500	261,750	349,000	523,500	26900	3x1	3					
KEC 464	18,420	184,200	276,300	368,400	552,600	26000							
KEC 564	22,240	222,400	333,600	444,800	667,200	26700	4x1	4					
KEC 584	23,250	232,500	348,750	465,000	697,500	35800							
KEC 664	26,320	263,200	394,800	526,400	789,600	35700	2x2	4					
KEC 674	26,840	268,400	402,600	536,800	805,200	34300							
KEC 734	29,360	293,600	440,400	587,200	880,800	35600	1x4						
KEC 744	29,660	296,600	444,900	593,200	889,800	35600	1x5	5					
KEC 874	34,780	347,800	521,700	695,600	1,043,400	42900	2x3	6					
KEC 884	34,960	349,600	524,400	699,200	1,048,800	51900							
KEC 954	38,130	381,300	571,950	762,600	1,143,900	53500	2x4	8					
KEC 1104	44,040	440,400	660,600	880,800	1,321,200	53400							
KEC 1164	46,610	466,100	699,150	932,200	1,398,300	69300							
KEC 1274	50,830	508,300	762,450	1,016,600	1,524,900	71300							
KEC 1344	53,670	536,700	805,050	1,073,400	1,610,100	68700	2x5	10					
KEC 1474	58,720	587,200	880,800	1,174,400	1,761,600	71200							
KEC 1564	63,540	635,400	953,100	1,270,800	1,906,200	89200							
KEC 1844	73,400	734,000	1,101,000	1,468,000	2,202,000	83600							
KEC 1854	73,930	739,300	1,108,950	1,478,600	2,217,900	89200	2x6	12					
KEC 1954	78,080	780,800	1,171,200	1,561,600	2,342,400	85800							
KEC 2004	79,930	799,300	1,198,950	1,598,600	2,397,900	91700							
KEC 2224	88,710	887,100	1,330,650	1,774,200	2,661,300	90600							
KEC 2354	93,720	937,200	1,405,800	1,874,400	2,811,600	89500							

(1) For R-404A, and 507 application multiply the R-22 capacity by .985 .

For 134a application multiply the R-22 capacity by .94 .

PHYSICAL DATA

TABLE 5 - "KCC" MODELS (1140 RPM MOTORS)

MODEL NUMBER	FIG	DIMENSIONS				CONNECTION (2)		SHIP. WT. (lbs)	
		H (in)	L (in)	W (in)	C (in)	H.G. OD (in)	LIQ. OD (in)		
KCC 295	1	46	85-1/4		83-3/4	(2)1-3/8	(2)1-1/8	690	
KCC 335								730	
KCC 375								790	
KCC 425								850	
KCC 495								990	
KCC 525								1030	
KCC 635			1170						
KCC 665			1450						
KCC 755			1540						
KCC 765			1440						
KCC 835			1880						
KCC 845			1680						
KCC 995			1690						
KCC 1005			1950						
KCC 1085		56-3/4	127 3/4		125-3/4	(2) 2-1/8	(2)1-3/8	2020	
KCC 1255								2480	
KCC 1335								2540	
KCC 1455								2640	
KCC 1535								3010	
KCC 1675								3100	
KCC 1815			212-3/4			210-3/4	(2) 2-5/8	(2)1-5/8	3220
KCC 2095									3450
KCC 2115									3470
KCC 2235									3640
KCC 2285									3880
KCC 2535									4120
KCC 2685	2	50	241-3/4	95-5/8	N/A	(2) 3-1/8	(2)2-1/8	4630	
			289-3/4						

TABLE 5A - "KEC" MODELS (850 RPM MOTORS)

MODEL NUMBER	FIG	DIMENSIONS				CONNECTION (2)		SHIP. WT. (lbs)		
		H (in)	L (in)	W (in)	C (in)	H.G. OD (in)	LIQ. OD (in)			
KEC 254	1	46	85-1/4		83-3/4	(2) 1-3/8	(2) 1-1/8	708		
KEC 294								748		
KEC 334								808		
KEC 374								868		
KEC 434								1017		
KEC 464								1057		
KEC 564			1197							
KEC 584			1486							
KEC 664			1576							
KEC 674			1476							
KEC 734			1916							
KEC 744			56-3/4	127 3/4		125-3/4		(2)2-1/8	(2) 1-3/8	1716
KEC 874										1735
KEC 884										2004
KEC 954		2074								
KEC 1104		2534								
KEC 1164		2612								
KEC 1274		170-1/4	85-1/2		168-1/4	(2) 2-5/8	(2)1-5/8	2712		
KEC 1344								3082		
KEC 1474								3172		
KEC 1564								3310		
KEC 1844								3540		
KEC 1854								3560		
KEC 1954		2	50	241-3/4	95-5/8	N/A	(2) 3-1/8	(2) 2-1/8	3730	
KEC 2004				3988						
KEC 2224				4228						
KEC 2354	4738									

(2) Connection sizes are based on R-22, 502, and 404A application only. Contact Kramer for connection sizes if refrigerant or system quantity is different.

PHYSICAL DATA

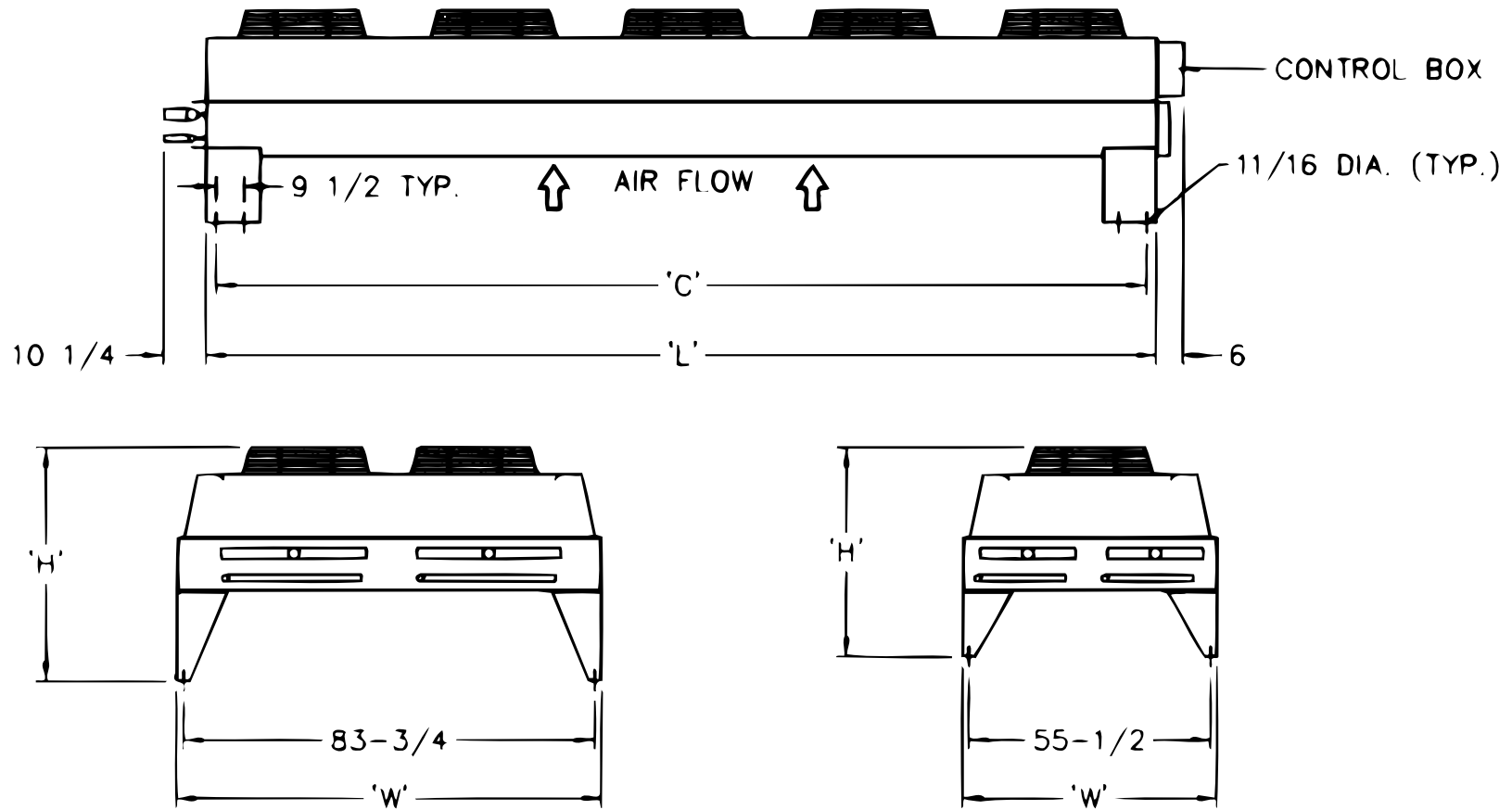

- MOUNTING LEGS ARE SHIPPED LOOSE FOR FIELD INSTALLATION.
- MOUNTING HOLES ARE 11/16" OD.
- ALL DIMENSIONS ARE IN INCHES.

FIGURE 1

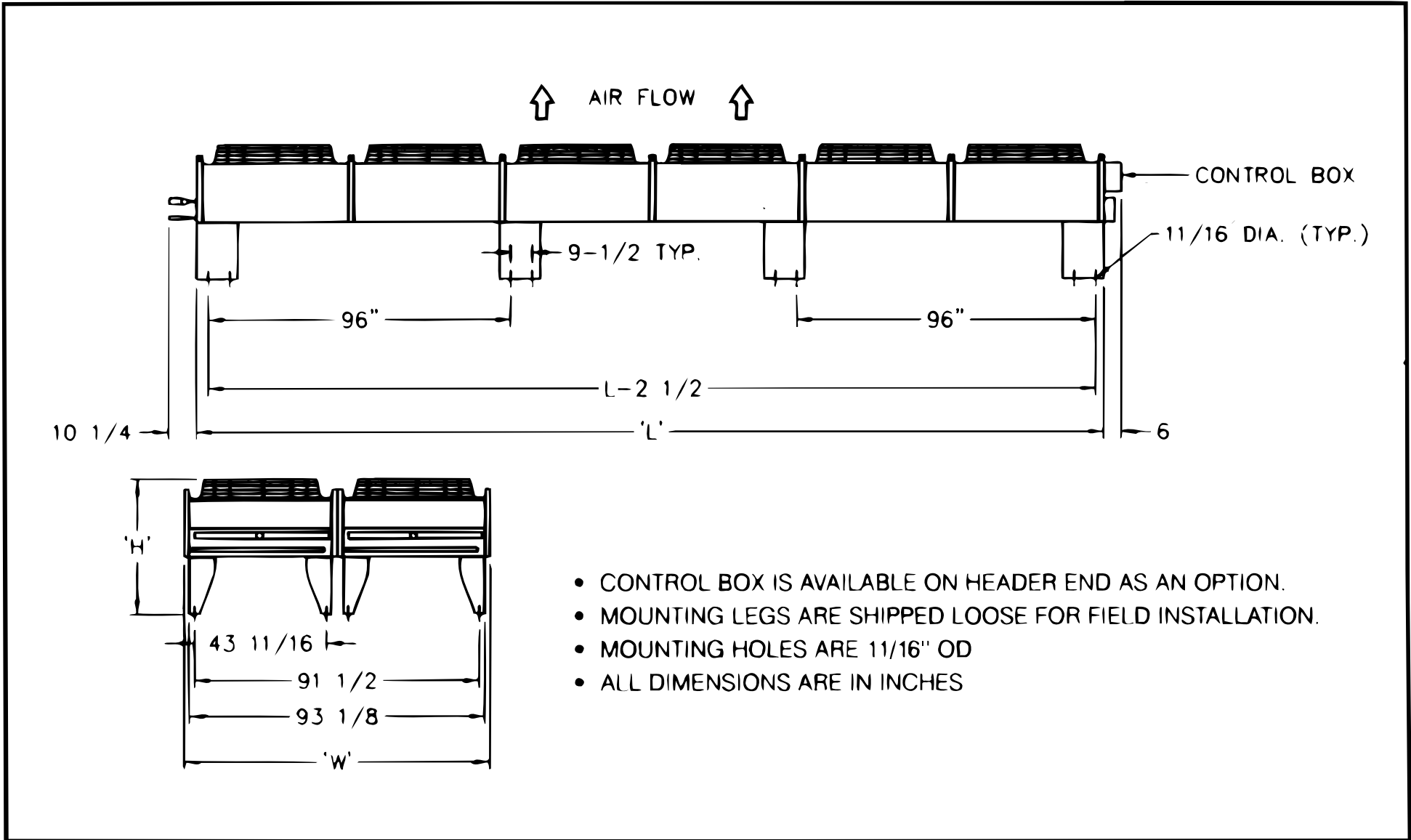

FIGURE 2

For your convenience the diagram(s) originally here has(have) been enlarged, and can be found just prior to this page in the Adobe document.

HEAD PRESSURE CONTROLS

LOW AMBIENT HEAD PRESSURE CONTROLS

A decrease in ambient air temperature results in a capacity increase in the air-cooled condenser. This capacity increase is directly proportional to the temperature difference of the ambient air entering the condenser. Since most refrigerating and air conditioning systems are designed for summer operation, it follows that when the same system operates under low ambients resulting from seasonal changes there occurs an increase in the condenser capacity, with a consequent reduction in the system head pressure. If the head pressure drops below the point where the expansion valve can properly feed the evaporator, inefficient system operation will result.

To maintain adequate head pressure in the condenser under low ambient conditions, Kramer offers two basic control methods: (1) fan cycling on multiple fan units; (2) flooding the condenser with liquid refrigerant.

FAN CYCLING HEAD PRESSURE CONTROL

The fan cycling head pressure control option is available on all multiple fan condenser models. This option offers satisfactory head pressure control to minimum ambients as low as 18°F on some models. See table 6 for specific details on minimum ambients and field thermostat settings.

TABLE 6

DESIGN TD	MINIMUM OUTSIDE AIR TEMPERATURE AT PERCENT COMPRESSOR CAPACITY SHOWN																			
	1 x 2 & 2 x 2 FAN UNITS				1 x 3 & 2 x 3 FAN UNITS				1 x 4 & 2 x 4 FAN UNITS				1 x 5 & 2 x 5 FAN UNITS				1 x 6 & 2 x 6 FAN UNITS			
	100	75	50	25	100	75	50	25	100	75	50	25	100	75	50	25	100	75	50	25
30	35	39	42	56	15	24	32	51	-2	11	24	47	-17	0	16	43	-30	-10	10	40
25	45	46	47	58	27	33	38	54	13	22	31	51	1	13	25	48	-10	5	20	45
20	54	53	52	61	40	42	45	57	28	33	39	54	19	26	34	52	10	20	30	50
15	63	60	56	63	52	51	51	60	44	45	47	58	36	40	43	57	30	35	40	55
10	72	66	61	65	62	61	57	64	59	57	54	62	54	53	52	61	50	50	50	60

REFRIGERANT CHARGE

Charging of a system should be carried out using visual reference to the refrigerant sight glass. Charging should be stopped when the sight glass becomes clear. Care must be taken when charging a system with a blended or near azeotropic refrigerant. If you are unfamiliar with the proper charging procedures, contact your refrigerant supplier for assistance.

The summer design refrigerant charge necessary for effective system operation is the sum of operating charge for the evaporator, refrigerant piping (suction, liquid and discharge lines), condenser and receiver. The pump-down capacity of the receiver should be somewhat greater (10% to 15%) than the total refrigerant charge required. When using a low ambient control system, additional refrigerant, over and above the summer design system charge, must be added to the system to allow for condenser flooding. The amount of this added charge is determined by the ambient in which the condenser will operate. Tables 7 and 7A list the total unit charge for all Kramer single systems.

The control package consists of factory wired weathertight control box. Each fan is individually sectioned off to prevent air bypass. All control options are UL listed and consist of the following:

- **Ambient control** consists of 1 to 5 thermostats. On KCC and KEC models the sensing bulbs are mounted in a specially designed sensing well that uses the condenser fan to move the ambient air over the sensing bulb of the thermostats. All fans, except for the first fan(s) closest to the header, will cycle.
- **Pressure control** consists of pressure stats which cycle the fans in response to the head pressure.
- **Ambient and pressure control** consists of 1 to 5 thermostats which cycled all but the closest fan(s) to the header end, which are cycled by pressure stats.
- **Control voltage** is 208-230V as standard. Optional 115V or 24V control voltages are available upon request.
- **Additional motor protection** can be supplied via fuses or circuit breakers. On all double fan width units, motors are protected in pairs, but optional individual motor protection is also available.

Use the following example for calculating the refrigerant charge for each compressor system or condenser, follow the example below:

Given:

- KCC 845 (4 fans long)
- Design TD: 20°F
- Flooded control, no fan cycling
- R-22
- Minimum design ambient: 40°F

Solution:

1. Select the total charge from Table 7 for the KCC 845 condenser, using R-22 refrigerant.
2. Select the appropriate correction factor from Table 3 for the ambient temperature range at time of charging.
3. Use Equation (1) to calculate the total unit charge for the condenser.

Eq. 1:

System Cond. Chg. = total unit charge x correction factor
 System Cond. Chg. = 79.6 x 3.0 System Cond. Chg. = 238.8 lbs.

REFRIGERANT CHARGE (cont.)

TABLE 7 - "KCC" MODELS (1140 RPM MOTORS)

MODEL NUMBER	MAX. NO. OF PASSES	MAX. NO OF COMPRS.	CAP. PER PASS (R-22) Btu/hr @ 1 TD	REFR. CHARGE (lbs) (3)
KCC 295	27	10	434.1	16.3
KCC 335	37		359.2	21.7
KCC 375	30	12	501.3	27.1
KCC 425	37		458.1	32.5
KCC 495			538.9	32.2
KCC 525		16	568.9	32.2
KCC 635	687		48.2	
KCC 665	24	718.4	42.6	
KCC 755		813	41	
KCC 765		667	53.3	
KCC 835		56	599.3	79.6
KCC 845		37	916.2	79.6
KCC 995		30	1,325.0	60.8
KCC 1005		56	713.6	48.7
KCC 1085		46	947.4	60.8
KCC 1255		56	898.9	96.8
KCC 1335		36	951.4	64.5
KCC 1455	1,263.0		80.6	
KCC 1535	1,333.7		100.4	
KCC 1675	56		1,198.6	120.5
KCC 1815	46		1,578.9	100.4
KCC 2095	56		1,498.2	120.5
KCC 2115	50		1,690.0	122.1
KCC 2235			1,785.0	122.1
KCC 2285			1,827.2	115.4
KCC 2535			2,028.0	144.2
KCC 2685		2,142.4	144.2	

TABLE 7A • "KEC" MODELS (850 RPM MOTORS)

MODEL NUMBER	MAX. NO. OF PASSES	MAX. NO OF COMPRS.	CAP. PER PASS (R-22) Btu/hr @ 1 TD	REFR. CHARGE (lbs) (3)
KEC 254	27	10	379.6	16.3
KEC 294	37		314.3	21.7
KEC 334	30	12	438.7	27.1
KEC 374	37		400.8	32.5
KEC 434			471.6	32.2
KEC 464		16	497.8	32.2
KEC 564	601.1		48.2	
KEC 584	24	628.4	42.6	
KEC 664		711.4	41	
KEC 674		46	583.5	53.3
KEC 734		56	524.3	79.6
KEC 744		37	801.6	79.6
KEC 874		30	1,159.3	60.8
KEC 884		56	624.3	48.7
KEC 954		46	828.9	60.8
KEC 1104		56	786.4	96.8
KEC 1164		36	832.3	64.5
KEC 1274	46		1,105.0	80.6
KEC 1344	1,166.7		100.4	
KEC 1474	56		1,048.6	120.5
KEC 1564	46		1,381.3	100.4
KEC 1844	56		1,310.7	120.5
KEC 1854	50		1,478.6	122.1
KEC 1954			1,561.6	122.1
KEC 2004			1,598.6	115.4
KEC 2224			1,774.2	144.2
KEC 2354		1,874.4	144.2	

(3) Refrigerant charge is based on R-22

TABLE 8 - REFRIGERANT CHARGE CORRECTION FACTOR WITH FLOODED-TYPE HEAD PRESSURE CONTR

UNIT LENGTH	DESIGN TD	MINIMUM DESIGN AMBIENT TEMPERATURE								
		60°	50°	40°	30°	20°	10°	0°	-10°	-20°
ALL SIZES	WITHOUT FAN CYCLING									
	30°	1.07	1.88	2.36	2.68	2.92	3.09	3.22	3.33	3.43
	25°	1.61	2.28	2.68	2.95	3.15	3.29	3.40	3.49	3.56
	20°	2.15	2.68	3.00	3.22	3.36	3.49	3.57	3.65	3.70
	15°	2.68	3.09	3.33	3.49	3.59	3.70	3.75	3.81	3.85
	10°	3.22	3.49	3.65	3.75	3.83	3.88	3.93	3.97	4.00
TWO FAN CELLS LONG	WITH FAN CYCLING									
	30°	1.03	1.05	1.07	1.60	1.99	2.28	2.50	2.68	2.83
	25°	1.05	1.07	1.60	2.06	2.37	2.60	2.80	2.95	3.09
	20°	1.05	1.60	2.15	2.50	2.76	2.95	3.11	3.22	3.32
	15°	1.60	2.28	2.68	2.95	3.15	3.29	3.41	3.49	3.62
	10°	2.50	2.95	3.22	3.41	3.53	3.60	3.69	3.75	3.81
THREE FAN CELLS LONG	30°	1.01	1.01	1.03	1.05	1.07	1.37	1.77	2.03	2.24
	25°	1.01	1.03	1.05	1.15	1.59	1.92	2.19	2.40	2.58
	20°	1.04	1.06	1.27	1.77	2.04	2.40	2.62	2.78	2.92
	15°	1.06	1.37	2.03	2.40	2.68	2.88	3.05	3.17	3.28
	10°	1.78	2.40	2.78	3.05	3.22	2.34	3.46	3.53	3.61
FOUR FAN CELLS LONG	30°	1.01	1.01	1.01	1.02	1.04	1.06	1.23	1.54	1.79
	25°	1.01	1.01	1.03	1.05	1.07	1.43	1.74	2.01	2.21
	20°	1.02	1.04	1.07	1.23	1.67	2.01	2.33	2.46	2.62
	15°	1.05	1.07	1.54	2.01	2.33	2.58	2.75	2.92	3.05
	10°	1.23	2.01	2.46	2.75	2.98	3.15	3.27	3.37	3.45
FIVE FAN CELLS LONG	30°	1.00	1.00	1.00	1.00	1.00	1.01	1.01	1.06	1.36
	25°	1.00	1.00	1.00	1.00	1.00	1.01	1.04	1.63	1.85
	20°	1.00	1.00	1.00	1.01	1.20	1.63	2.07	2.19	2.36
	15°	1.01	1.01	1.12	1.63	2.03	2.32	2.52	2.72	2.87
	10°	1.01	1.65	2.13	2.46	2.72	2.92	3.10	3.23	3.33
SIX FAN CELLS LONG	30°	1.00	1.00	1.00	1.00	1.00	1.00	1.00	1.06	1.09
	25°	1.00	1.00	1.00	1.00	1.00	1.01	1.08	1.25	1.51
	20°	1.00	1.00	1.00	1.00	1.08	1.21	1.79	1.94	2.10
	15°	1.00	1.00	1.00	1.18	1.71	2.04	2.26	2.52	2.74
	10°	1.00	1.35	1.83	2.19	2.37	2.69	2.94	3.11	3.23

WIRING DIAGRAM

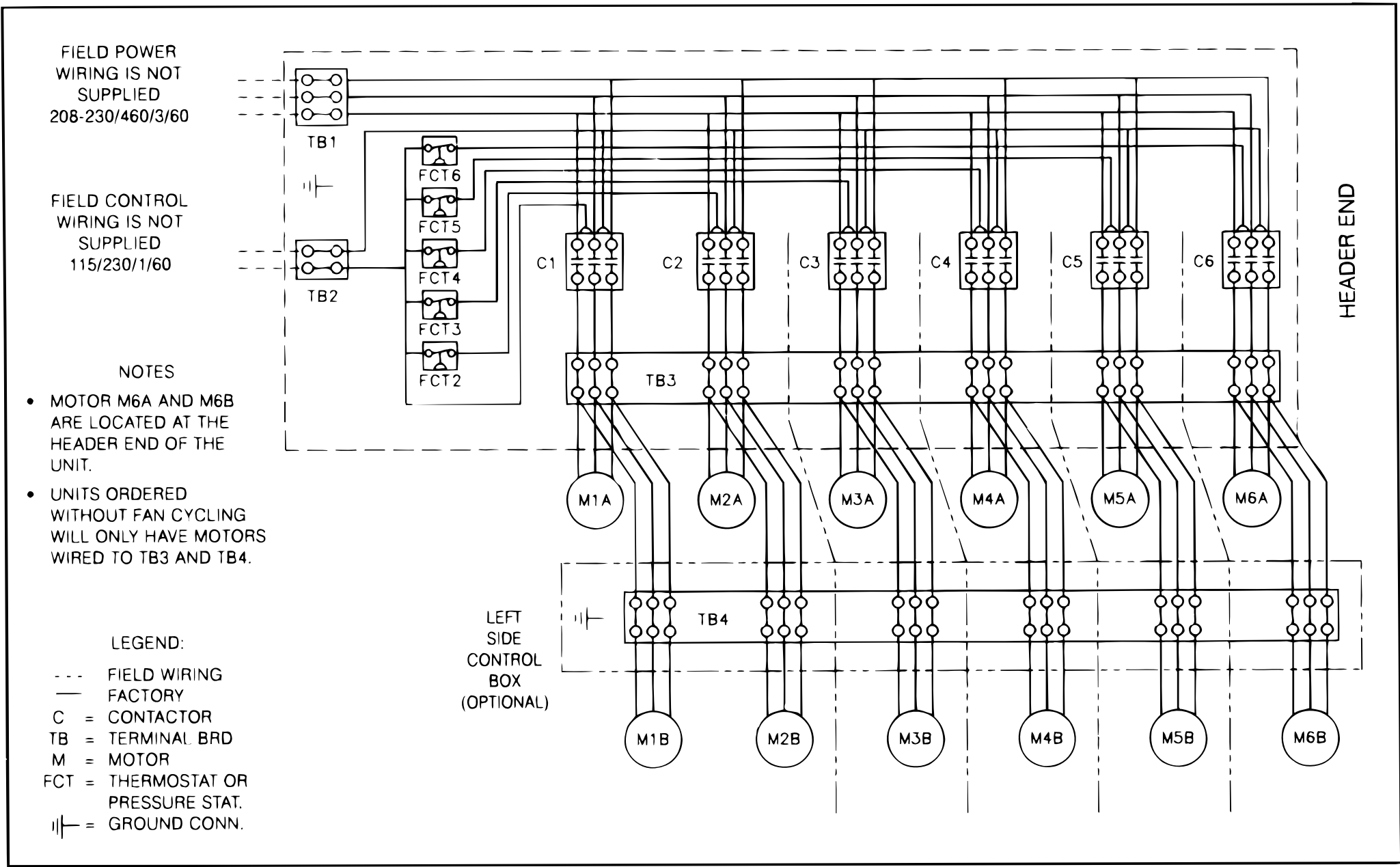

FIGURE 3: KCC and KEC 3 phase wiring diagram for single and double row fan models with fan control.