

LIST PRICES

August 2016

INDEX

AIR COOLED CONDENSERS

STYLE CDS, CDL, RCS, RCL, WCS, WFS, WFL, CDC, WCL, WCE _ _ _ _ 18-20

WALK-IN / WAREHOUSE EVAPORATORS

SUPERFLO - SA, SE, SG, SH _ _ _ _ _	3
SUPERFLO - SDA, SDE, SDG _ _ _ _ _	4
SUPERFLO - SFA, SFE, SFG _ _ _ _ _	5
MINI-MAX - MMA, MME, MMG _ _ _ _ _	5
DUAL FLO - DFA, DFE EASY FLO - WWA, WWE, WWG _ _ _ _ _	6
EASY FLO - EFA, EFE, EFG _ _ _ _ _	7
INTERFLO - IFA, IFE, IFG, IFH _ _ _ _ _	8-9
POLARFLO - P*A,P*L, P*M, PAH _ _ _ _ _	10-11
POWER-MAX PMA, PME, PMG _ _ _ _ _	12
LO VELAIR - LAA, LAE, LAG _ _ _ _ _	7
Surveillant Demand Defrost Controller replacement Parts _ _ _ _ _	8

CONDENSING UNITS

PWS, PWH, PWZ, P*H, P*S, P*O, P*D, G*H, G*S, G*O, G*D _ _ _ _ _	21
"W" SERIES, "WD" SERIES, "WV" SERIES _ _ _ _ _	22

REACH - IN EVAPORATORS

ASL _ _ _ _ _	13
FLEX AIR - FT _ _ _ _ _	12
MINI TWIN AIR - MTW _ _ _ _ _	14
MULLION AIR - MDF, MUF _ _ _ _ _	14
SLIM AIR - SL, SLA, SLE _ _ _ _ _	14-15
T-AIR - TT _ _ _ _ _	16
TWIN AIR - TW _ _ _ _ _	16
WALL AIR - WA _ _ _ _ _	17
WEDGE AIR - WE _ _ _ _ _	17
APEX - XN, XT _ _ _ _ _	23

ORDERING INFORMATION

- All orders are subject to a \$50.00 net minimum billing.
- All orders are subject to Witt's Terms and Conditions of Sale.
- All parts are shipped FOB point of shipping:
 - Parts are typically shipped in cardboard cartons/unless size or weight will not permit.
 - Any PARTS order that requires crating cannot be shipped by United Parcel Service.
 - An example of parts that must be crated are metal components such as; venturi panels, drain pans, long defrost heaters.
 - Defrost heaters are shipped straight whenever possible, all heaters are shipped with heater hooks.
 - PSC motors are shipped less their capacitors, unless specifically ordered.
- Warranty on all parts is 90 days from date of invoice.
- When ordering replacement parts for a unit, if the exact part number is not available, it is very important that the complete model number, serial number, and voltage be provided. This information will help determine the exact vintage of the unit.

NOMENCLATURE

Using the Witt evaporator nomenclature, the following information can be extracted; number of fans, fin spacing. The following example applies to Witt evaporators, with the exception of ASL and SL models which have their defrost designation in the suffix position.

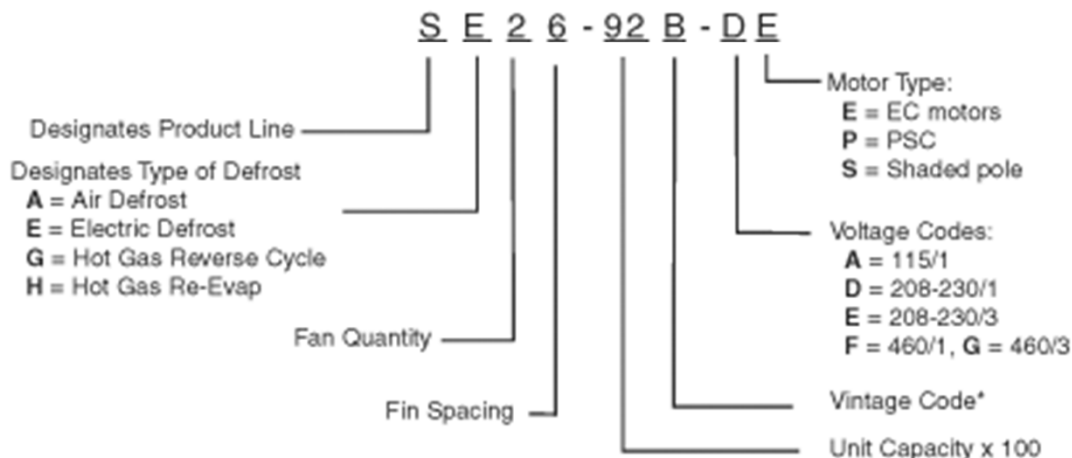

* If an "X" is in the Vintage position, or at the beginning of the model number, the unit was built with a modification or special component that deviates from the standard description.

SERIAL NUMBERS

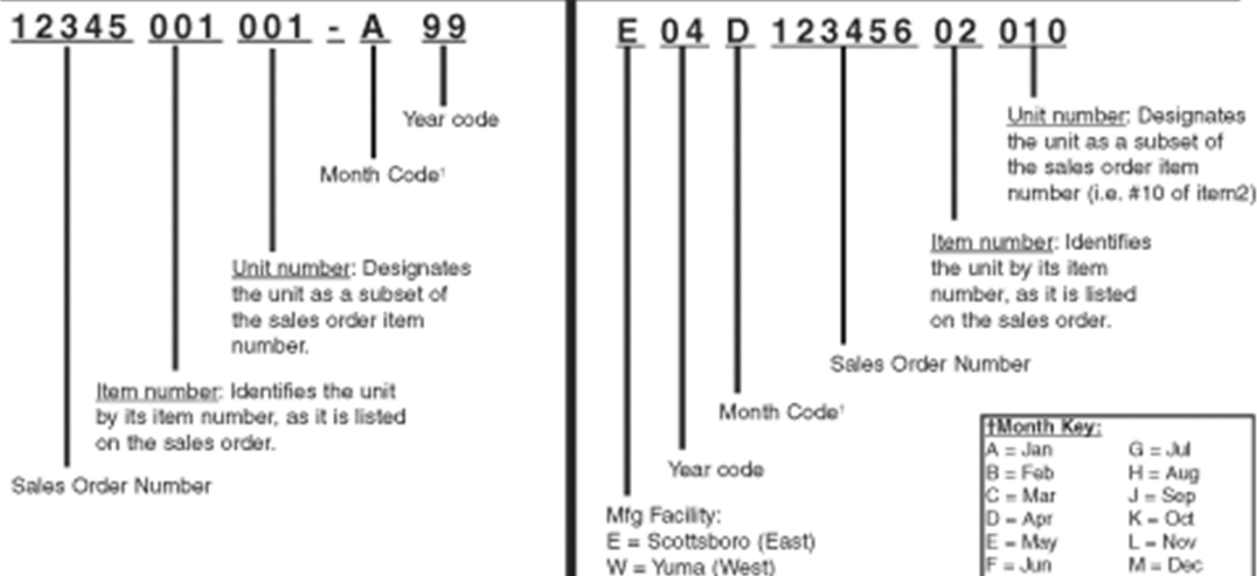

REPLACEMENT PARTS - LISTING BY PRODUCT MODEL NUMBER

SUPER - FLO — MODELS SA, SE, SG, SH

MODEL NUMBER	DESCRIPTION	PART NUMBER	LIST PRICE
ALL "SE" MODELS	DEFROST CONTROL, DEFROST TERMINATION, (TIMER RESET) 2 WIRE	103079010	122
ALL "SE" MODELS	DEFROST CONTROL, FAN DELAY, 2 WIRE	103079009	122
1 - 6 FAN SE MODELS	HEATER SAFETY SWITCH, 2 WIRE	103079003	111
SE14-37, SE16-36, SE16-41, SE16-46	DEFROST HEATER, CORE, 500 WATTS, 26-1/4" LENGTH, 208-230/460 V. DEFROST HEATER, DRAIN PAN, 500 WATTS, 21" LENGTH, 208-230/460 V.	206240006 200172042	343 264
SE24-72, SE24-85, SE26-92	DEFROST HEATER, CORE, 1000 WATTS, 44-1/4" LENGTH, 208-230/460 V. DEFROST HEATER, DRAIN PAN, 1000 WATTS, 39" LENGTH, 208-230/460 V.	206240008 200172044	294 274
SE26-60, SE26-75	DEFROST HEATER, CORE, 800 WATTS, 40-1/4" LENGTH, 208-230/460 V. DEFROST HEATER, DRAIN PAN, 800 WATTS, 35" LENGTH, 208-230/460 V.	206240007 200172043	274 264
SE34-105, SE36-120, SE36-140	DEFROST HEATER, CORE, 1500 WATTS, 62-1/4" LENGTH, 208-230/460 V. DEFROST HEATER, DRAIN PAN, 1500 WATTS, 57" LENGTH, 208-230/460 V.	206240009 200172045	342 325
SE44-140, SE46-164, SE46-185	DEFROST HEATER, CORE, 2000 WATTS, 80-1/4" LENGTH, 208-230/460 V. DEFROST HEATER, DRAIN PAN, 2000 WATTS, 75" LENGTH, 208-230/460 V.	206240010 200172046	435 414
SE54-180, SE56-210	DEFROST HEATER, CORE, 2500 WATTS, 97-3/4" LENGTH, 208-230/460 V. DEFROST HEATER, DRAIN PAN, 2500 WATTS, 93" LENGTH, 208-230/460 V.	206240011 200172047	505 467
SE64-215, SE66-245, SE66-280	DEFROST HEATER, CORE, 3000 WATTS, 115-3/4" LENGTH, 208-230/460 V. DEFROST HEATER, DRAIN PAN, 3000 WATTS, 111" LENGTH, 208-230/460 V.	206240012 200172048	535 524
ALL MODELS	FAN GUARD, PLASTIC, BLACK, 12"	119647000	88
SUPER-FLO MODELS (NOT EC MTRS)	FAN BLADE, 12" DIAM., 24° PITCH, 5-BLADE, CW (For Shaded Pole & PSC motors)	08221153	71
SUPER-FLO MODELS W/PSC OR SHADED POLE MOTORS	MOTOR MOUNT	21062000	122
	MOTOR, PSC, 1/20 HP, 1550 RPM, 115 V (3 MFD CAPACITOR NOT INCLUDED)	08216074	259
	MOTOR, PSC, 1/20 HP, 1550 RPM, 230 V., (2 MFD CAPACITOR NOT INCLUDED)	108178002	296
	CAPACITOR, 3 MFD, FOR 1/20 115 V. PSC MOTOR	202163010	40
	CAPACITOR, 2 MFD, FOR 1/20 230 V. PSC MOTOR	202163009	45
	MOTOR, SHADED POLE, 1/20 HP, 1550 RPM, 115 V.	08216072	189
	MOTOR, SHADED POLE, 1/20 HP, 1550 RPM, 208-230 V.	102540004	189
	MOTOR, SHADED POLE, 1/20 HP, 1550 RPM, 460 V.	08216034	280
SUPER-FLO MODELS W/EC Motors	FAN BLADE, 12" DIAM., 24° PITCH, CW (Required for EC Motors)	08221175	67
SUPER-FLO MODELS W/EC Motors	MOTOR MOUNT LEG (For use with EC Motors) (3 required for complete mount)	08522938	38
	MOTOR, ECM, 50 WATT, 1550 RPM, 115 V, CCW	08216124	579
	MOTOR, ECM, 50 WATT, 1550 RPM, 230 V, CCW	08216125	610
ECM RETRO-FIT KIT FOR	115 V MOTOR, KIT INCLUDES MOTOR, HARDWARE, MOUNT, & BLADE	08523048	818
ALL SUPER-FLO MODELS	230 V MOTOR, KIT INCLUDES MOTOR, HARDWARE, MOUNT, & BLADE	08523049	871

FOR MODELS PRODUCED AFTER APRIL, 2004

1 FAN SA, & SE MODELS	DRAIN PAN, 27" LENGTH	08519592	351
SA28-76, -97, -122, SA26-70, -87, SE26-60, SE26-75	DRAIN PAN, 41" LENGTH	08519593	395
SA28-106, SA28-134, SE24-85	DRAIN PAN, 45" LENGTH	08519594	395
3 FAN SA & SE MODELS	DRAIN PAN, 63" LENGTH	08519595	436
4 FAN SA & SE MODELS*	DRAIN PAN, 81" LENGTH	08519596	608
5 FAN SA & SE MODELS*	DRAIN PAN, 99" LENGTH	08519597	666
6 FAN SA & SE MODELS*	DRAIN PAN, 117" LENGTH	08519598	718
1 FAN SG, & SH MODELS	DRAIN PAN, 27" LENGTH	08525457	351
SG/H26-60, SG/H26-75	DRAIN PAN, 41" LENGTH	08525458	395
SG/H26-92, SG/H24-72, SG/H24-85	DRAIN PAN, 45" LENGTH	08525459	395
3 FAN SH & SG MODELS	DRAIN PAN, 63" LENGTH	08525160	436
4 FAN SH & SG MODELS*	DRAIN PAN, 81" LENGTH	08525461	608
5 FAN SH & SGE MODELS*	DRAIN PAN, 99" LENGTH	08525462	666
6 FAN SH & SG MODELS*	DRAIN PAN, 117" LENGTH	08525463	718
ALL MODELS	ELECTRICAL SIDE HINGED END PANEL	08518612	135
ALL MODELS	PIPING SIDE HINGED END PANEL	08518613	135

FOR MODELS PRODUCED BEFORE APRIL, 2004

1 FAN SA, & SE MODELS	DRAIN PAN, 27" LENGTH	20927501	351
SA28-76, -97, -122, SA26-70, -87, SE26-60, SE26-75	DRAIN PAN, 41" LENGTH	20927502	395
SA28-106, SA28-134, SA26-115, SE24-75, SE24-85, SE26-92	DRAIN PAN, 45" LENGTH	20927503	395
3 FAN SA & SE MODELS	DRAIN PAN, 63" LENGTH	20927601	436
4 FAN SA & SE MODELS*	DRAIN PAN, 81" LENGTH	20927602	608
5 FAN SA & SE MODELS*	DRAIN PAN, 99" LENGTH	20927701	666
6 FAN SA & SE MODELS*	DRAIN PAN, 117" LENGTH	20927702	718
1 FAN SG, & SH MODELS	DRAIN PAN, 27" LENGTH	20935800	351
SG26-60, SH26-60, SE24-72 SG26-75, SH26-75, SE24-85	DRAIN PAN, 41" LENGTH	20935900	395
SG24-72, SG26-92, SG24-85, SH24-72, SH24-85, SH26-92	DRAIN PAN, 45" LENGTH	20936000	395
3 FAN SG, & SH MODELS	DRAIN PAN, 63" LENGTH	20936100	436
4 FAN SG, & SH MODELS*	DRAIN PAN, 81" LENGTH	20936200	608
5 FAN SG, & SH MODELS*	DRAIN PAN, 99" LENGTH	20936300	666
6 FAN SG, & SH MODELS*	DRAIN PAN, 117" LENGTH	20936400	718

* ALL 4 - 6 FAN MODEL DRAIN PANS SHIP VIA COMMON CARRIER ONLY, NO UPS.

SUPER - FLO — EVAPORATORS, SDA, SDE, SDG

MODEL NUMBER	DESCRIPTION	PART NUMBER	LIST PRICE
ALL MODELS	MOTOR, SHADED POLE, 1/20 HP, 1550 RPM, 115 V.	08216072	\$189
	MOTOR, SHADED POLE, 1/20 HP, 1550 RPM, 208-230 V.	102540004	189
	MOTOR, SHADED POLE, 1/20 HP, 1550 RPM, 460 V.	08216034	280
	MOTOR, PSC, 1/20 HP, 1550 RPM, 115 V., (3 MFD CAPACITOR NOT INCLUDED)	08216074	259
	MOTOR, PSC, 1/20 HP, 1550 RPM, 230 V.	08216073	296
	FAN BLADE, 12", 24° PITCH, 5/16 BORE, CW	08221153	71
	MOTOR MOUNT	21062000	122
	ACCESS PANEL, ELECTRICAL END, MILL FINISH ALUM	08513866	124
	ACCESS PANEL, ELECTRICAL END, EMBOSSED ALUM	08513870	133
	ACCESS PANEL, HEADER END, MILL FINISH ALUM	08513867	124
	ACCESS PANEL, HEADER END, EMBOSSED ALUM	08513871	133
	DRAIN PLUG, 3/4" FEMALE COUPLING	08248059	31
	DRAIN PLUG, HEX HEAD MPT	08218111	35
	FAN GUARD, 12" WIRE, EPOXY COATED BEFORE 12/99	08397040	102
	FAN GUARD, 12" POLYPROPYLENE, AFTER JAN, 2000	119647000	88
	SDE038M, 049, 050M, 060M 036LM 040L, 046L, 052L	DEFROST HEATER, 380 WATTS, 24-1/4" LENGTH, 240 VOLT	08215114
085M, 055L, 075L, 078L 088L	DEFROST HEATER, 685 WATTS, 41-1/4" LENGTH, 240 VOLT	08215115	153
080M, 102M, 105M, 124M 065L, 089L, 120L	DEFROST HEATER, 760 WATTS, 45-1/4" LENGTH, 240 VOLT	08215116	207
125M, 150M, 170M 110L, 140L, 160L	DEFROST HEATER, 990 WATTS, 58-1/4" LENGTH, 240 VOLT	08215117	236
168M, 210M, 135L, 180L	DEFROST HEATER, 1150 WATTS, 67-1/4" LENGTH, 240 VOLT	08215118	293
214M, 254M, 215L, 181L	DEFROST HEATER, 1295 WATTS, 75-1/4" LENGTH, 240 VOLT	08215119	301
255M, 305M, 220L, 240L	DEFROST HEATER, 1600 WATTS, 92-1/4" LENGTH, 240 VOLT	08215120	340
225M, 350M, 260L, 265L, 300L	DEFROST HEATER, 1905 WATTS, 109-1/4" LENGTH, 240 VOLT	08215121	491
ALL SDE	DEFROST TERMINATION/FAN DELAY THERMOSTAT	08219247	74
ALL FAN SDE MODELS	HEATER SAFETY SWITCH, 2 WIRE	103079003	111
ALL SDG MODELS	DEFROST TERMINATION THERMOSTAT	08219242	38
LOW TEMP SDG MODELS	FAN DELAY, 1-3 FANS	08219240	35
	FAN DELAY, 4-6 FANS	08219246	68
054H, 066H, 074H, 038M 049M, 050M, 060M, 036L 040L, 046L, 052L,	DRAIN PAN*, 1 FAN, EMBOSSED ALUMINUM, 26 1/2" LENGTH	08513872	303
	DRAIN PAN*, 1 FAN, MILL FINISH ALUMINUM	08513826	321
090H, 108H, 080M, 102M 055L, 075L, 078L, 088L	DRAIN PAN*, 2 FAN, EMBOSSED ALUMINUM, 43 1/2" LENGTH	08513873	345
	DRAIN PAN*, 2 FAN, MILL FINISH ALUMINUM	08513827	359
119H, 139H, 085M, 105M, 124M, 065L, 089L, 120L	DRAIN PAN*, 2 FAN EXT., EMBOSSED ALUMINUM, 47 1/2" LENGTH	08513874	352
	DRAIN PAN*, 2 FAN EXT., MILL FINISH ALUMINUM	08513828	370
171H, 201H, 125M, 150M 170M, 110L, 140L, 160L	DRAIN PAN*, 3 FAN, EMBOSSED ALUMINUM, 60 1/2" LENGTH	08513875	382
	DRAIN PAN*, 3 FAN, MILL FINISH ALUMINUM	08513829	403
230H, 168M, 210M 135L, 180L	DRAIN PAN*, 3 FAN EXT., EMBOSSED ALUMINUM, 69 1/2" LENGTH	08513876	401
	DRAIN PAN*, 3 FAN EXT., MILL FINISH ALUMINUM	08513830	419
270H, 214M, 254M 181L, 215L	DRAIN PAN*, 4 FAN, EMBOSSED ALUMINUM, 77 1/2" LENGTH	08513877	535
	DRAIN PAN*, 4 FAN, MILL FINISH ALUMINUM	08513831	561
330H, 225M, 305M 220L, 240L	DRAIN PAN*, 5 FAN, EMBOSSED ALUMINUM, 94 1/2" LENGTH	08513878	587
	DRAIN PAN*, 5 FAN, MILL FINISH ALUMINUM	08513832	613
410H, 325M, 350M 260L, 265L, 300L	DRAIN PAN*, 6 FAN, EMBOSSED ALUMINUM, 111 1/2" LENGTH	08513879	632
	DRAIN PAN*, 6 FAN, MILL FINISH ALUMINUM	08513833	661

* CALL FACTORY FOR SFG, LOW TEMP DRAIN PANS HOT GAS DEFROST

SUPER-FLO — EVAPORATORS (BLOW THROUGH UNITS) SFA, SFE, SFG

MODEL NUMBER	DESCRIPTION	PART NUMBER	LIST PRICE
ALL MODELS	MOTOR, SHADED POLE, 1/20 HP, 1550 RPM, 115 V.	08216072	\$189
	MOTOR, SHADED POLE, 1/20 HP, 1550 RPM, 208-230 V.	102540004	189
	MOTOR, SHADED POLE, 1/20 HP, 1550 RPM, 460 V.	08216034	280
	MOTOR, PSC, 1/20 HP, 1550 RPM, 115 V., (3 MFD CAPACITOR NOT INCLUDED)	08216074	259
	MOTOR, PSC, 1/20 HP, 1550 RPM, 230 V.	08216073	296
	FAN BLADE, 12", 24° PITCH, 5/16 BORE, CCW	08221169	68
	FAN GUARD 12", WIRE, EPOXY COATED	08397040	102
	MOTOR MOUNT	21062000	122
	ACCESS PANEL, ELECTRICAL END	08512042	124
	ACCESS PANEL, HEADER END	08512041	124
054H, 066H, 074H, 049M, 050M, 060M, 036L, 040L, 046L, 052L	DRAIN PAN*, 1 FAN	08512044	303
090H, 108H, 080H, 102M, 055L, 075L, 078L, 088L	DRAIN PAN*, 2 FAN	08512046	345
119H, 139H, 085M, 105M, 124M, 065L, 089L	DRAIN PAN*, 2 FAN EXTENDED LENGTH	08512047	352
171H, 201H, 125M, 150M, 170M, 110L, 140L, 160L	DRAIN PAN*, 3 FAN	08512048	382
230H, 168M, 210M 120L, 135L, 180L	DRAIN PAN*, 3 FAN EXTENDED LENGTH	08512049	401
270H, 214M, 254M, 181L, 215L	DRAIN PAN*, 4 FAN	08512050	535
330H, 255M, 305M 220L, 240L	DRAIN PAN*, 5 FAN	08512051	587
410H, 325M, 350M 260L, 265L, 300L	DRAIN PAN*, 6 FAN	08512043	632

* FOR LOW TEMP, HOT GAS DRAIN PANS, CONSULT FACTORY FOR PRICING AND AVAILABILITY.

ALL SFE MODELS	DEFROST HEATERS, 987 WATTS, 230V	08215110	\$138
	DEFROST HEATERS, 987 WATTS, 460V	08215111	NLA
	DEFROST TERMINATION THERMOSTAT	NLA	—
	DEFROST HEATER SAFETY	08219243	98
ALL SFG MODELS	DEFROST TERMINATION THERMOSTAT	08219242	38
ALL LOW TEMP	FAN DELAY THERMOSTAT, 1-3 FANS	08219240	35
SFE, SFG MODELS	FAN DELAY THERMOSTAT, 4-6 FANS	08219246	68

MINI-MAX EVAPORATOR - MMA, MME, MMG

MODEL NUMBER	DESCRIPTION	PART NUMBER	LIST PRICE
MMA040 - MMA050	DRAIN PAN*	N / A	—
MMA060 - MMA103	DRAIN PAN*	N / A	—
MMA124 - MMA150	DRAIN PAN*	N / A	—
MMA184 - MMA200	DRAIN PAN*	N / A	—
MMA250	DRAIN PAN*	N / A	—
MMA300	DRAIN PAN*	N / A	—
MME036	DRAIN PAN*	N / A	—
MME060 - MME072	DRAIN PAN*	N / A	—
MME090 - MME120	DRAIN PAN*	N / A	—
MME144 - MME160	DRAIN PAN*	N / A	—
MME180 - MME200	DRAIN PAN*	N / A	—
MME216 - MME240	DRAIN PAN*	N / A	—
ALL MODELS	MOTOR, SHADED POLE, 1/20 HP, 1550 RPM, 115 V.	08216072	\$189
	MOTOR, SHADED POLE, 1/20 HP, 1550 RPM, 208-230 V.	102540004	189
	MOTOR, SHADED POLE, 1/20 HP, 1550 RPM, 460 V.	08216034	280
	MOTOR, PSC, 1/20 HP, 1550 RPM, 115 V.	08216074	259
	MOTOR, PSC, 1/20 HP, 1550 RPM, 230 V.	08216073	296
	MOTOR MOUNT	NLA	—
	FAN BLADE, 10", 31° PITCH, 5/16 BORE, CW	08221006	42
	FAN GUARD, WIRE, EPOXY COATED 10", BLACK	08397002	88
ALL MME, MMG MODELS	FAN DELAY, DEFROST TERMINATION THERMOSTAT, RANCO F-25	204464037	325

*ALL DEFROST HEATERS AND SHEET METAL PARTS OBSOLETE

NLA - No Longer Available

ORIGINAL MOTORS 1/30HP

DUAL- FLO — MODELS DFA, DFE

MODEL NUMBER	DESCRIPTION	PART NUMBER	LIST PRICE
ALL MODELS	DEFROST CONTROL, DEFROST TERMINATION, (TIMER RESET) 2 WIRE	103079010	\$122
ALL MODELS	DEFROST CONTROL, FAN DELAY, 2 WIRE	103079009	122
DFE34-48, DFE34-58, DFE34-65, DFE36-53, DFE36-62, DFE36-69	DEFROST HEATERS, CORE, 1037 WATTS, 55" LENGTH, 208-230/460 V. (2 REQ'D)	208579001	340
DFE44-72, DFE44-84, DFE44-95, DFE46-77, DFE46-90, DFE46-100	DEFROST HEATERS, 1490 WATTS, 79" LENGTH, 208-230/460 V. (2 REQ'D)	208579002	463
DFE54-115, DFE44-152, DFE54-145, DFE64-173, DFE56-125, DFE46-140, DFE56-160, DFE66-218	DEFROST HEATERS, 1943 WATTS, 103 LENGTH, 208-230/460 V. (2 REQ'D)	208579003	510

SPECIFY DRAIN CONNECTION LOCATION WHEN ORDERING DFA/DFE DRAIN PANS, BOTTOM OR SIDE.*

ALL 3 FAN DFA/DFE MODELS	DRAIN PAN, 58-1/2 LENGTH, SPECIFY DRAIN CONNECTION LOCATION	20860901	\$487
ALL 4 FAN DFA/DFE MODELS EXCEPT AS FOLLOWS	DRAIN PAN, 82-1/2 LENGTH, SPECIFY DRAIN CONNECTION LOCATION	20861001	619
DFA46-190, DFA48-210, DFE44-128, DFE46-140	DRAIN PAN, 106-1/2 LENGTH, SPECIFY DRAIN CONNECTION LOCATION	20861101	712
ALL 5 FAN DFA/DFE MODELS	DRAIN PAN, 106-1/2 LENGTH, SPECIFY DRAIN CONNECTION LOCATION	20861201	712
ALL 6 FAN DFA/DFE MODELS	DRAIN PAN, 106-1/2 LENGTH, SPECIFY DRAIN CONNECTION LOCATION	20861301	740
ALL MODELS	FAN BLADE, 10" DIAM., 31° PITCH, CCW, HUBLESS	204395018	47
ALL MODELS	FAN GUARD, PLASTIC, 12" (BLACK) (STANDARD)	119647000	88
ALL MODELS (OPTIONAL)	FAN GUARD, WIRE, EPOXY COATED, 12" (OPTIONAL)	201006011	88
ALL MODELS	HEATER SAFETY SWITCH, 2 WIRE	103079003	111
ALL MODELS	MOTOR, ECM, 16 WATT, 1550 RPM, 115V	107933006	616
EC MOTORS	MOTOR, ECM, 16 WATT, 1550 RPM, 230V	107933003	639
ALL MODELS	MOTOR, SHADED POLE, 16 WATT, 1550 RPM, 115Volts	103104007	174
ALL MODELS	MOTOR, SHADED POLE, 16 WATT, 1550 RPM, 208-230V/1/60	103104008	174
ALL MODELS (OPTIONAL)	CAPACITOR, 1.2 MFD, FOR 16 WATT 230 V. PSC MOTOR	202163015	45
ALL MODELS (OPTIONAL)	MOTOR, PSC, 16 WATTS, 1550 RPM, 115 V., (5 MFD CAPACITOR NOT INCLUDED)	107933001	354
	MOTOR, PSC, 16 WATTS, 1550 RPM, 230 V., (2 MFD CAPACITOR NOT INCLUDED)	107933003	NLA
	CAPACITOR, 1.2 MFD, FOR 16 WATT 230 V. PSC MOTOR	202163015	45
	CAPACITOR, 5 MFD, FOR 16 WATT 115 V. PSC MOTOR	202163004	42
ALL MODELS	CAPACITOR, 2 MFD, FOR 16 WATT 230 V. PSC MOTOR	202163009	45
	MOTOR, MOUNT	10243000	88

* ALL DUAL-FLO DRAIN PANS SHIP VIA COMMON CARRIER ONLY, NO UPS.

EASY- FLO — MODELS WWF

WWF050, 100, 130, 160, 190, 220, 270, 340	115/230 VOLT - FAN BLADE, 10 IN. DIA., 31° PITCH, CCW, HUBLESS	204395018	\$47
WWF - 075	115/230 VOLT - FAN BLADE, 10 IN. DIA., 20° PITCH, CCW, HUBLESS	204395016	47
WWF-050, 100, 130, 160, 190, 220, 270, 340	460V - FAN BLADE, 10 IN. DIA., 28° PITCH, CCW	08221007	47
WWF - 075	460V - FAN BLADE, 10 IN. DIA., 13° PITCH, CCW	08221005	47
All Models	FAN GUARD, 12 IN. BLACK PLASTIC	119647000	88
	MOTOR MOUNT (Except for 460V PSC motor, See Below)	10243000	88
All Models - EC MOTORS	MOTOR, EC, 16W, 1550 RPM, 115V	107933006	616
	MOTOR, EC, 16W, 1550 RPM, 230V	107933003	639
	MOTOR MOUNT	10243000	88
All Models - PSC MOTORS (Optional)	MOTOR, PSC, 16 WATT, 1550 RPM, 115 V.	107933001	354
	CAPACITOR, 5 MFD, FOR 16 WATT 115 V. PSC MOTOR	202163004	42
	MOTOR, PSC, 1/15HP, 1550 RPM, 460V	08216135	461
	MOTOR MOUNT, 460V PSC	0825489400	88
All Models - SHADED POLE MOTORS (Optional)	MOTOR, SHADED POLE, 16 WATT, 1550 RPM, 115 V.	103104007	174
	MOTOR, SHADED POLE, 16 WATT, 1550 RPM, 230 V.	103104008	174
WWF - 050	DRAIN PAN/VENTURI PANEL	0852507601	409
WWF - 075, 100	DRAIN PAN/VENTURI PANEL, 2 FAN	0852507701	561
WWF - 130, 160	DRAIN PAN/VENTURI PANEL, 3 FAN	0852507801	621
WWF - 190, 220	DRAIN PAN/VENTURI PANEL, 4 FAN	0852507901	712
WWF - 270	DRAIN PAN/VENTURI PANEL, 5 FAN	0852508001	809
WWF - 340	DRAIN PAN/VENTURI PANEL, 6 FAN	0852508101	881
WWF - 050 (Optional)	DRAIN PAN/VENTURI PANEL, 1 FAN, WHITE PAINTED	0852507607	612
WWF - 075, 100 (Optional)	DRAIN PAN/VENTURI PANEL, 2 FAN, WHITE PAINTED	0852507707	772
WWF - 130, 160 (Optional)	DRAIN PAN/VENTURI PANEL, 3 FAN, WHITE PAINTED	0852507807	939
WWF - 190, 220 (Optional)	DRAIN PAN/VENTURI PANEL, 4 FAN, WHITE PAINTED	0852507907	947
WWF - 270 (Optional)	DRAIN PAN/VENTURI PANEL, 5 FAN, WHITE PAINTED	0852508000	1,052
WWF - 340 (Optional)	DRAIN PAN/VENTURI PANEL, 6 FAN, WHITE PAINTED	0852508107	1,125
WWF - 050	DEFROST HEATER 545W, 42 IN. LONG (2 PER UNIT)	0821500901	315
WWF - 075, 100	DEFROST HEATER 545W, 61 IN. LONG (2 PER UNIT)	0821500902	336
WWF - 130, 160, 190, 220	DEFROST HEATER 1305W, 79 IN. LONG (2 PER UNIT)	0821500903	388
WWF - 270	DEFROST HEATER 2180W, 90 IN. LONG (2 PER UNIT)	0821500904	439
WWF - 340	DEFROST HEATER 2725W, 114 IN. LONG (2 PER UNIT)	0821500905	497
All Electric and Hot Gas Defrost Models	DEFROST CONTROL, TERMINATION (STANDARD)	103079010	122
	DEFROST CONTROL, ADJUSTABLE (OPTIONAL)	204464037	325
	DEFROST CONTROL, HEATER SAFETY (STANDARD)	103079003	111

LO VELAIR, MODELS LAA, LAE, LAG

MODEL NUMBER	DESCRIPTION	PART NUMBER	LIST PRICE
495	DRAIN PANS	NLA	—
740	DRAIN PANS	NLA	—
975 - 1460	DRAIN PANS	NLA	—
1950 - 2600	DRAIN PANS	NLA	—
ALL MODELS	MOTOR, 1/20 HP, 115 VOLT, 1550 RPM, CW, SHADED POLE	08216072	\$189
	MOTOR, 1/20 HP, 115 VOLT, PSC, 1550 RPM, CW	08216074	259
	MOTOR, 1/20 HP, 230 VOLT, SHADED POLE, 1550 RPM, CW	102540004	189
	MOTOR, 1/20 HP, 230 VOLT, PSC, 1550 RPM, CW	08216073	296
	MOTOR, 1/20 HP, 460 VOLT, SHADED POLE, 1550 RPM, CW	08216034	280
	MOTOR MOUNT	08513975	122
	FAN GUARD, BLACK	08397002	88
95, 1220, 495, 1460 950, 1950, 2600	DEFROST TERMINATION, FAN DELAY	204464037	325
	FAN BLADE, 10" DIAMETER, 28° PITCH, 5/16 BORE, CCW	08221007	47
740, 975	FAN BLADE, 10" DIAMETER, 13° PITCH, 5/16 BORE CCW	08221005	47

EASY-FLO — MODELS, EFA, EFE, AND EFG

MODEL NUMBER	DESCRIPTION	PART NUMBER	LIST PRICE
ALL MODELS	MOTOR, SHADED POLE, 115 VOLT, 1550 RPM	08216072	\$189
	MOTOR, SHADED POLE, 230 VOLT, 1550 RPM	102540004	189
	MOTOR, SHADED POLE, 460 VOLTS, 1550 RPM	08216034	280
	MOTOR, PSC, 115 VOLT, 1550 RPM	08216074	259
	MOTOR, PSC, 230 VOLT, 1550 RPM	08216073	296
	MOTOR, ECM , 1/30 HP, 1550 RPM, 115V	8216126	720
	MOTOR, ECM , 1/30 HP, 1550 RPM, 230V	8216127	751
	DRAIN FITTING, 3/4" FEMALE COUPLING	08248059	31
	DRAIN FITTING, NIPPLE, HEX HEAD, MPT	08218111	35
	FAN BLADE, 10" 13° PITCH, 5/16 BORE, CCW	08221007	47
	FAN GUARD, 10", WIRE, EPOXY, BLACK	08397002	88
	FAN GUARD, AFTER 5/11/00, 10" POLYPROPYLENE, WHITE	08397053	88
	EFA,EFE,EFG, 075M	FAN BLADE, 10" 28° PITCH, 5/16 BORE, CCW	08221005
EFE, ALL ELECTRIC DEFROST MODEL	DEFROST TERMINATION, THERMOSTAT	NLA	—
	DEFROST HEATER SAFETY	08219243	98
EFG, HOT GAS MODELS	DEFROST TERMINATION THERMOSTAT	08219242	38
EFE 050M	DEFROST HEATER, 545 WATTS , 42" LENGTH , 240 V	08215015	120
EFE 75M, 100M	DEFROST HEATER, 545 WATTS , 61" LENGTH , 240 V	08215016	213
EFE 130M, 160M, 190M, 220M	DEFROST HEATER, 1305 WATTS , 79" LENGTH , 240 V	08215018	236
EFE 270M	DEFROST HEATER, 2160 WATTS , 240 V	08215112	377
EFE 340M	DEFROST HEATER, 2125 WATTS , 240 V	08215113	435
FOR MODELS PRODUCED PRIOR TO 2000			
EFA,EFE,EFG, 050M	DRAIN PAN	08512851	\$409
EFA, EG, 075M, 100M	DRAIN PAN	08512852	437
EFA, EG, 130M, 160M	DRAIN PAN	08512853	603
EFA, EG, 190M, 220M	DRAIN PAN	08512854	665
EFA, EG, 270M	DRAIN PAN	08512855	714
EFA, EG, 340M	DRAIN PAN	08512856	785
FOR MODELS PRODUCED AFTER 2000			
EFA, EFE, EFG, 050M	DRAIN PAN	08517434	\$409
EFA, EG, 075M, 100M	DRAIN PAN	08517435	437
EFA, EG, 130M, 160M	DRAIN PAN	08517436	603
EFA, EG, 190M, 220M	DRAIN PAN	08517437	665
EFA, EG, 270M	DRAIN PAN	08517438	714
EFA, EG, 340M	DRAIN PAN	08517439	785
EFA, EFE, EFG, 050M	KIT,DRAIN PAN,EF*050M*	08517825	748
EFA, EG, 075M	KIT,DRAIN PAN,EF*075M*	08517833	1,417
EFA, EG, 100M	KIT,DRAIN PAN,EF*100M*	08517832	1,271
EFA, EG, 130M	KIT,DRAIN PAN,EF*130M*	08517826	1,517
EFA, EG, 160M	KIT,DRAIN PAN,EF*160M*	08517827	1,550
EFA, EG, 190M	KIT,DRAIN PAN,EF*190M*	08517828	2,086
EFA, EG, 220M	KIT,DRAIN PAN,EF*220M*	08517829	2,086
EFA, EG, 270M	KIT,DRAIN PAN,EF*270M*	08517830	2,007
EFA, EG, 340M	KIT,DRAIN PAN,EF*340M*	08517831	2,163
EFA, E, G, 050M 075M, 100M	ACCESS COVERS, ELECTRICAL END	08513130	109
	ACCESS COVER, HEADER END	08513126	109
EFA, E, G, 130M	ACCESS COVERS, ELECTRICAL END	08513131	115
	ACCESS COVER, HEADER END	08513127	115
EFA, E, G, 160M	ACCESS COVERS, ELECTRICAL END	08513132	121
	ACCESS COVER, HEADER END	08513128	121
EFA, E, G, 190M, 220M 270M, 340M	ACCESS COVERS, ELECTRICAL END	08513133	124
	ACCESS COVER, HEADER END	08513129	124

NLA - No Longer Available

SURVEILLANT - Demand Defrost Controller replacement Parts

Demand Defrost Control parts	Surveillant Evaporator Control	08219537	2343
	Electronic Expansion Valve - less cable	08219539	453
	EEV power cable for AA/AE evaporator	08219516	231
	EEV Power Cable for CTA/CTE evaporators	08219517	229
	Return Air Temperature Sensor for AA/AE	08219522	133
	Return Air Temperature Sensor for CTA/CTE	08219523	133
	Air sensor mounting wire	08219978	9
	Coil Temperature sensor for AA/AE	08219524	133
	Coil Temperature sensor for CTA/CTE	08219525	133
	Coil Temperature sensor for CTA/CTE (AUX)	08219526	133
	Suction Temperature sensor for AA/AE	08219520	133
	Suction Temperature sensor for CTA/CTE	08219521	133
	Transducer only - No cable	08219981	356
	Transducer Cable for AA/AE evaporators	08219518	186
	Transducer Cable for CTA/CTE	08219519	186
	Strain relief wire	08219528	3
Smartgate Router	08219541	2778	

INTER - FLO — MODELS IFA, IFE, IFG, IFH PRODUCED BEFORE MARCH, 1996

MODEL NUMBER	DESCRIPTION	PART NUMBER	LIST PRICE
ALL MODELS	FAN BLADES, 14" DIAM., 32° PITCH, CW	214100000	\$190
ALL MODELS	FAN GUARD, WIRE, EPOXY COATED, 14" (original part 213626002 - No Longer A v.)	203626003	NLA
ALL IFA 2 FAN MODELS	DRAIN PAN, 45-1/2" LENGTH*	214147000	NLA
ALL IFA 3 FAN MODELS	DRAIN PAN, 63-1/2" LENGTH*	214148000	NLA
ALL IFA 4 FAN MODELS	DRAIN PAN, 81-1/2" LENGTH*	214149000	NLA
ALL IFA 5 FAN MODELS	DRAIN PAN, 99-1/2" LENGTH*	214150000	NLA
ALL IFE, IFG, IFH MODELS	DEFROST CONTROL, ADJUSTABLE, RANCO F-25	204464037	325
IFE24-110, IFE24-150, IFE26-125, IFE26-170	DEFROST HEATERS, CORE, 671 WATTS, 47" LENGTH, 230 V. (4 REQ'D)	112755000	NLA
	DEFROST HEATERS, DRAIN PAN, 238 WATTS, 97-7/8" LENGTH, 230 V. (2 REQ'D)	113889000	325
	DRAIN PAN, 45-1/2" LENGTH*	214151000	437
IFE34-225, IFE36-256	DEFROST HEATERS, CORE, 959 WATTS, 65" LENGTH, 230 V. (4 REQ'D)	112756000	NLA
	DEFROST HEATERS, DRAIN PAN, 168 WATTS, 70-1/8" LENGTH, 230 V. (4 REQ'D)	113888000	NLA
	DRAIN PAN, 63-1/2" LENGTH*	214152000	NLA
IFE44-300, IFE46-340	DEFROST HEATERS, CORE, 1247 WATTS, 83" LENGTH, 230 V. (4 REQ'D)	112757000	NLA
	DEFROST HEATERS, DRAIN PAN, 213 WATTS, 88-1/4" LENGTH, 230 V. (4 REQ'D)	113887000	NLA
	DRAIN PAN, 81-1/2" LENGTH*	214153000	NLA
IFE54-380, IFE56-430	DEFROST HEATERS, CORE, 1535 WATTS, 101" LENGTH, 230 V. (4 REQ'D)	112758000	NLA
	DEFROST HEATERS, DRAIN PAN, 258 WATTS, 106-1/8" LENGTH, 230 V. (4 REQ'D)	113886000	NLA
	DRAIN PAN, 99-1/2" LENGTH*	214154000	NLA
CONTACT FACTORY FOR HOT GAS DRAIN PAN PRICING			

FOLLOWING MOTORS ARE FOR UNITS PRODUCED BEFORE JANUARY 1, 1994.

ALL MODELS	MOTOR, SHADED POLE, 1/8 HP, 1050 RPM, 115V.(CAPACITOR NOT INCLUDED)	122830000	\$704
	MOTOR , PSC, 1/8 HP, 1050 RPM, 230V. (CAPACITOR NOT INCLUDED)	049-146	NLA
	MOTOR, SHADED POLE, 1/15 HP, 1050 RPM, 460V.	NLA	—
ALL 115V MODELS	CAPACITOR, 10 MFD, FOR 1/15 HP 115 V. PSC MOTOR	08216063	42
ALL 230V MODELS	CAPACITOR, 5 MFD, FOR 1/8 HP 230 V. PSC MOTOR	202163004	42
ALL 460V MODELS	CAPACITOR, 7.5 MFD, FOR 1/8 HP 460 V. PSC MOTOR	202163006	45

FOLLOWING MOTORS ARE FOR UNITS PRODUCED BETWEEN APRIL 30, 1994 AND MARCH, 1996.

ALL MODELS	MOTOR, PSC, 1/8 HP, 1050 RPM, 115 V., (CAPACITOR NOT INCLUDED)	122830000	\$704
	MOTOR, PSC, 1/8 HP, 1050 RPM, 230 V., (CAPACITOR NOT INCLUDED)	049-146	NLA
	MOTOR, PSC, 1/8 HP, 1050 RPM, 460 V., (CAPACITOR NOT INCLUDED)	049-175	748
ALL 115V MODELS	CAPACITOR, 10 MFD, FOR 1/15 HP 115 V. PSC MOTOR	08216063	42
ALL 230V MODELS	CAPACITOR, 5 MFD, FOR 1/8 HP 230 V. PSC MOTOR	202163007	42
ALL 460V MODELS	CAPACITOR, 7.5 MFD, FOR 1/8 HP 460 V. PSC MOTOR	202163006	45

INTER FLO - MODELS IFA, IFE, IFG, IFH PRODUCED AFTER MARCH, 1996

IFA24-126,-169, IFA34-224,-287 IFA26-145,-191, IFA36-240,-305	FAN BLADE, 14" 32° PITCH, CW	214100000	\$190
IFA28-151,-210, IFA38-260,-320	FAN GUARD, 14" WIRE, EPOXY COATED, BLUE	213626002	NLA
IFE24-105, -140, IFE34-175	FAN GUARD, 14" WIRE, EPOXY COATED, BLACK	213626003	111
IFE26-130, -150, IFE36 -185	FAN GUARD, AIR STRAIGHTENER, 14"	113447000	NLA
IFA24-340,-395, IFA34-465,-585 IFA26-370, IFA36-415,-490,-620 IFA28-410,-450, IFA38-540,-690	FAN BLADE, 20" 25° PITCH, CW	213456000	256
IFE24-230,-325, IFE34-390,-510	FAN GUARD, WIRE, EPOXY COATED, 20", BLACK	213484000	210
IFE26-270, IFE26-320, IFE36-385 IFE36-460, IFE36-520	FAN GUARD, EPOXY, AIR STRAIGHTENER, 20"	106923000	358

* "IF" DRAIN PANS MUST SHIP VIA COMMON CARRIER. NO UPS SHIPMENTS
NLA - NO LONGER AVAILABLE

INTER -FLO — MODELS IFA, IFE, IFG, IFH PRODUCED AFTER MARCH, 1996 (CONT.)

MODEL NUMBER	DESCRIPTION	PART NUMBER	LIST PRICE	
IFA24-126,-169, IFA26-145,-191, IFA28-151,-210, IFE24-105,-140, IFE26-130,-150	DRAIN PAN, 55" LENGTH*	11523801	\$761	
IFA34-224,287, IFA36-240,-305, IFA38-260,-320, IFE34-175, IFE36-185	DRAIN PAN, 76" LENGTH*	11523901	841	
IFA24-340,-395, IFA26-370, IFA28-410,-450, IFE24-230,-325, IFE26-270,-320	DRAIN PAN, 76" LENGTH*	NLA	—	
IFA34-465,-585, IFA38-540,-690, IFA36-415,-490,-620, IFE34-390,-510, IFE36-460,-520	DRAIN PAN, 106" LENGTH*	11524101	841	
ALL IFE MODELS	DEFROST TERMINATION CONTROL	103079010	122	
ALL IFE MODELS	FAN DELAY CONTROL	103079009	122	
ALL IFE MODELS	HEATER SAFETY CONTROL	103079003	111	
IFE24-105, IFE24-140, IFE26-130, IFE26-150	DEFROST HEATERS, 240V, 1693 WATTS 50" LENGTH, 3 REQ.	206240022	300	
	DEFROST HEATERS, 460V, 1555 WATTS, 50" LENGTH, 3 REQ.	206240021	468	
	DEFROST HEATERS, 575V, 1555 WATTS, 50" LENGTH, 3 REQ.	206240030	468	
IFE34-175, IFE24-230, IFE24-325 IFE36-185, IFE26-270, IFE26-320	DEFROST HEATERS, 240V, 2458 WATTS, 70" LENGTH, 3 REQ.	206240004	394	
	DEFROST HEATERS, 460V, 2258 WATTS, 70" LENGTH, 3 REQ.	206240020	588	
	DEFROST HEATERS, 575V, 2258 WATTS, 70" LENGTH, 3 REQ.	206240029	588	
IFE34-390, IFE34-510, IFE36-385, IFE36-460, IFE36-520	DEFROST HEATERS, 240V, 3538 WATTS, 100" LENGTH, 3 REQ.	206240005	493	
	DEFROST HEATERS, 460V, 3249 WATTS, 100" LENGTH, 3 REQ.	206240019	673	
	DEFROST HEATERS, 575V, 3249 WATTS, 100" LENGTH, 3 REQ.	206240028	673	
IFA24-126,-169, IFA34-224,-287 IFA26-145,-191, IFA36-240,-305 IFA28-151,-210, IFA38-260,-320	MOTOR, PSC, 115V, 1/8 HP, 1075 RPM (4 MFD CAP. NOT INCLUDED)	115248001	704	
	CAPACITOR, 4MFD, FOR 1/8 HP (115 V, 230V, 460V.) PSC MOTOR	202163012	42	
	MOTOR, ECM , 115V, 1/8 HP, 1075 RPM	08216128	857	
	MOTOR, PSC, 115V, 1/3 HP, 1075 RPM (NO LONGER AVAILABLE use 205051020)	205051005	—	
	MOTOR, PSC, 115V, 1/3 HP, 1075 RPM, LO-GRSE (5 MFD CAP. NOT INCLUDED)	205051020	764	
IFA24-340,-395, IFA34-465,-585 IFA26-370 IFA36,-415, -490,-620 IFA28-410,-450, IFA38-540,-690	CAPACITOR, 5MFD, FOR 1/3 HP (115V) PSC MOTOR	202163004	42	
	MOTOR, ECM , 115V, 1/3 HP, 1075 RPM	08216130	847	
	MOTOR, PSC, 230V, 1/8 HP, 1075 RPM (4 MFD CAP. NOT INCLUDED)	115248002	704	
	CAPACITOR, 4MFD, FOR 1/8 HP (115 V, 230V, 460V.) PSC MOTOR	202163012	42	
	MOTOR, ECM , 230V, 1/8 HP, 1075 RPM	08216129	888	
IFA24-340,-395, IFA34-465,-585 IFA26-370, IFA36-415, -490,-620 IFA28-410,-450, IFA38-540,-690 IFE24-230,-325, IFE34-390,-510 IFE26-270, IFE26-320 IFE36-385, IFE36-460, IFE36-520	MOTOR, PSC, 230V, 1/3 HP, 1075 RPM (NO LONGER AVAILABLE use 205051019)	205051004	—	
	MOTOR, PSC, 230V, 1/3 HP, 1075 RPM, LO-GRSE (5.0 MFD CAP. NOT INCLUDED)	205051019	865	
	CAPACITOR, 7.5 MFD, FOR 1/3 HP (230V, 460V) PSC MOTOR	202163006	45	
	MOTOR, ECM , 230V, 1/3 HP, 1075 RPM	08216131	1033	
	MOTOR, PSC, 460V, 1/8 HP, 1075 RPM (4 MFD CAP. NOT INCLUDED)	115248003	748	
IFA24-126,-169, IFA34-224,-287 IFA26-145,-191, IFA36-240,-305 IFA28-151,-210, IFA38-260,-320 IFE24-105, IFE24-140, IFE34-175 IFE26-130, IFE26-150, IFE36-185	MOTOR, PSC, 575V, 1/8 HP, 1075 RPM (4 MFD CAP. NOT INCLUDED)	115951000	830	
	CAPACITOR, 4MFD, FOR 1/8 HP (115 V, 230V, 460V.) PSC MOTOR	202163012	42	
	MOTOR, PSC, 460V, 1/3 HP, 1075 RPM (NO LONGER AVAILABLE use 205051021)	205051006	—	
IFA24-340,-395, IFA34-465,-585 IFA26-370, IFA36-415, -490,-620 IFA28-410,-450, IFA38-540,-690 IFE24-230,-325, IFE34-390,-510 IFE26-270, IFE26-320 IFE36-385, IFE36-460, IFE36-520	MOTOR, PSC, 460V, 1/3 HP, 1075 RPM, LO-GRSE (7.5 MFD CAP. NOT INCLUDED)	205051021	932	
	MOTOR, PSC, 575V, 1/3 HP, 1075 RPM (7.5 MFD CAP. NOT INCLUDED)	115950000	887	
	CAPACITOR, 7.5 MFD, FOR 1/3 HP (230V, 460V) PSC MOTOR	202163006	45	
	MODELS WITH 14" FANS	MOTOR MOUNT 14"	21483700	119
	MODELS WITH 20" FANS	MOTOR MOUNT 20"	21022500	206

* "IF" DRAIN PANS MUST SHIP VIA COMMON CARRIER. NO UPS SHIPMENTS

BOLD PART NUMBERS ARE FOR REPLACEMENT MOTORS

POLAR - FLO — MODELS P*U, P*L, P*M, PAH

MODEL NUMBER	DESCRIPTION	PART NUMBER	LIST PRICE
ALL MODELS	DEFROST CONTROL, ADJUSTABLE, RANCO F-25	204464037	\$325
ALL 1 FAN MODELS	DEFROST HEATERS, CORE, 1378 WATTS, 40" LENGTH, 208-230/460 V. (4 REQ'D)	206240003	244
	DEFROST HEATERS, CORE, 1378 WATTS, 40" LENGTH, 575 V. (4 REQ'D)	206240025	306
ALL 2 FAN MODELS	DEFROST HEATERS, CORE, 2458 WATTS, 70" LENGTH, 208-230/460 V. (4 REQ'D)	206240004	394
	DEFROST HEATERS, CORE, 2458 WATTS, 70" LENGTH, 575 V. (4 REQ'D)	206240026	499
ALL 3 FAN MODELS	DEFROST HEATERS, CORE, 3538 WATTS, 100" LENGTH, 208-230/460 V. (4 REQ'D)	206240005	493
	DEFROST HEATERS, CORE, 3538 WATTS, 100" LENGTH, 575 V. (4 REQ'D)	206240027	639
PEU4-711	DEFROST HEATERS, CORE, 2305 WATTS, 132" LENGTH, 208-230/460 V. (8 REQ'D)	206240002	392
PEL4-817, PEL4-722	DEFROST HEATERS, CORE, 2305 WATTS, 132" LENGTH, 575 V. (8 REQ'D)	206240024	499
PEM4-780, PEM4-882			
PEU4-851, PEU4-1080,	DEFROST HEATERS, CORE, 2305 WATTS, 132" LENGTH, 208-230/460 V. (12 REQ'D)	206240002	392
PEL4-950, PEL4-1100, PEL4-1260,	DEFROST HEATERS, CORE, 2305 WATTS, 132" LENGTH, 575 V. (12 REQ'D)	206240024	499
PEL4-1380, PEM4-1100			
PEM4-1320, PEM4-1656			
PEU5-1350, PEL5-1575	DEFROST HEATERS, CORE, 2837 WATTS, 162" LENGTH, 208-230/460 V. (12 REQ'D)	206240017	453
PEL5-1725, PEM5-2065	DEFROST HEATERS, CORE, 2837 WATTS, 162" LENGTH, 575 V. (12 REQ'D)	NLA	—
PEU6-1620, PEL6-1890	DEFROST HEATERS, CORE, 3369 WATTS, 192" LENGTH, 208-230/460 V. (12 REQ'D)	206240018	543
PEL6-2070, PEM6-2480	DEFROST HEATERS, CORE, 3369 WATTS, 192" LENGTH, 575 V. (12 REQ'D)	NLA	—
ALL MODELS	DEFROST HEATER, DRAIN PLUG, 540 WATTS, 208-230/460 V.	10780703	NLA

FOLLOWING DRAIN PANS ARE FOR UNITS PRODUCED BEFORE JULY 31, 1995 (contact factory for Hot Gas Pans)**

1 FAN MODELS	DRAIN PAN, 46-1/2"LENGTH - (SHIPS FROM YUMA, AZ) SPECIFY MOD# AND S/N.	12270501	\$671
2 FAN MODELS	DRAIN PAN, 76-1/2"LENGTH - (SHIPS FROM YUMA, AZ) SPECIFY MOD# AND S/N.	12270502	753
3 FAN MODELS	DRAIN PAN, 106-1/2"LENGTH - (SHIPS FROM YUMA, AZ) SPECIFY MOD# AND S/N.	12270503	831
4 FAN MODELS**	DRAIN PAN, 136-1/2"LENGTH - (SHIPS FROM YUMA, AZ) SPECIFY MOD# AND S/N.	12270504	913
5 FAN MODELS**	DRAIN PAN, 166-1/2"LENGTH - (SHIPS FROM YUMA, AZ) SPECIFY MOD# AND S/N.	12270505	1105
6 FAN MODELS**	DRAIN PAN, 196-1/2"LENGTH - (SHIPS FROM YUMA, AZ) SPECIFY MOD# AND S/N.	21505600	1370

FOLLOWING DRAIN PANS ARE FOR UNITS PRODUCED AFTER JULY 31, 1995 (contact factory for Hot Gas Pans)**

1 FAN MODELS	DRAIN PAN, 46-1/2"LENGTH - (SHIPS FR YUMA, AZ) SPECIFY MOD# AND S/N.	10642401	\$671
2 FAN MODELS	DRAIN PAN, 76-1/2"LENGTH - (SHIPS FR YUMA, AZ) SPECIFY MOD# AND S/N.	10642402	753
3 FAN MODELS	DRAIN PAN, 106-1/2"LENGTH - (SHIPS FROM YUMA, AZ) SPECIFY MOD# AND S/N.	10642403	831
4 FAN MODELS (AIR DEFROST)	DRAIN PAN, 136-1/2"LENGTH - (SHIPS FROM YUMA, AZ) SPECIFY MOD# AND S/N.	10642404	913
5 FAN MODELS (AIR DEFROST)	DRAIN PAN, 166-1/2"LENGTH - (SHIPS FROM YUMA, AZ) SPECIFY MOD# AND S/N.	21884500	1105
6 FAN MODELS (AIR DEFROST)	DRAIN PAN, 196-1/2"LENGTH - (SHIPS FROM YUMA, AZ) SPECIFY MOD# AND S/N.	21884600	1214
4 FAN MODELS (ELEC. DEF)	DRAIN PAN, 136-1/2"LENGTH - (SHIPS FROM YUMA, AZ) SPECIFY MOD# AND S/N.	21485900	1069
5 FAN MODELS (ELEC. DEF)	DRAIN PAN, 166-1/2"LENGTH - (SHIPS FROM YUMA, AZ) SPECIFY MOD# AND S/N.	21512700	1260
6 FAN MODELS (ELEC. DEF)	DRAIN PAN, 196-1/2"LENGTH - (SHIPS FROM YUMA, AZ) SPECIFY MOD# AND S/N.	21505600	1370
4,5,6, FAN MODELS	DRAIN PAN, CONNECTION 1-1/4"	114896001	47

FOLLOWING DRAIN PAN HEATERS ARE FOR UNITS PRODUCED AFTER JULY 31, 1995**

1-3 FAN MODELS*	NOT AVAILABLE	NLA	—
4 FAN MODELS	DRAIN PAN HEATER, 133-1/2"LENGTH, SPEC. MOD# AND S/N. (2 REQ.), 540 WATTS	115098000	\$422
5 FAN MODELS	DRAIN PAN HEATER, 163-1/2"LENGTH, SPEC. MOD# AND S/N. (2 REQ.), 660 WATTS	115099000	476
6 FAN MODELS	DRAIN PAN HEATER, 196-1/2"LENGTH, SPEC. MOD# AND S/N. (2 REQ.), 780 WATTS	115100000	582

FOLLOWING FAN BLADES ARE FOR UNITS PRODUCED BEFORE APRIL 1, 1990.

ALL 1, 2, & 3 FAN P*U, AND P*L MODELS, AND P*U4-711, P*L4-722, P*L4-817	FAN BLADES, 20" DIAM., 23° PITCH, CCW, 1/2" BORE	202147008	\$293
P*U4-851, P*U4-1080, P*L4-1100, P*L4-1380 P*M4-1320, P*M4-1656, PAH4-1452, PAH4-1821	FAN BLADES, 24" DIAM., 32° PITCH, CW, 1/2" BORE	213455000	293
ALL 1, 2, & 3 FAN P*M, AND PAH MODELS, AND P*M4-780, P*M4-822, PAH4-866, PAH4-980	FAN BLADES, 20" DIAM., 25° PITCH, CW, 1/2" BORE	213456000	256

* NO DRAIN PAN HEATERS FOR 1 - 3 FAN MODELS (BOTTOM CORE HEATER DEFROSTS THE DRAIN PAN.)

** MUST SHIP VIA COMMON CARRIER. NO UPS SHIPMENTS

NLA - NO LONGER AVAILABLE

POLAR - FLO — MODELS P*U, P*L, P*M, PAH (Con't)

FOLLOWING FAN BLADES ARE FOR UNITS PRODUCED AFTER APRIL 1, 1990.			
P*U1-118, P*U2-236, P*L1-125 P*L1-152, P*L1-193, P*L2-240, P*L2-304	FAN BLADES, 20" DIAM., 23° PITCH, CCW , 1/2" BORE	202147008	\$293
P*U2-355, P*L2-361, P*L2-408, P*M4-1100, P*M4-1320, P*M4-1656, PAH4-1452, PAH4-1821, PAH5-2275, PAH6-2730, & ALL 3, 4, 5, & 6 FAN P*U AND P*L MODELS	FAN BLADES, 24" DIAM., 32° PITCH, CW, 1/2" BORE	213455000	293
P*M1-164, P*M1-209, P*M2-270, P*M2-239, PAH1-182, PAH1-232, PAH2-300, PAH2-365	FAN BLADES, 20" DIAM., 25° PITCH, CW, 1/2" BORE	213456000	256
P*M2-390, P*M2-441, PAH2-433, PAH2-490, ALL 3 FAN P*M, AND PAH MODELS P*M4-780, P*M4-882, P*M5-2065, P*M6-2480, PAH4-866, PAH4-980, PAH4-1100	FAN BLADES, 24" DIAM., 14° PITCH, CW , 1/2" BORE	214041000	283
P*U1-118, P*U2-236, P*L1-125, P*L1-152, P*L1-193, P*L2-240, P*L2-304, P*M1-164, P*M1-209, P*M2-270, P*M2-329, PAH1-182, PAH1-232, PAH2-300, PAH2-365	FAN GUARD, AIR STRAIGHTENER (20" FANS)	10692300	358
	FAN GUARD, WIRE, EPOXY COATED, 20"	213484000	210
P*U2-355, P*L2-361, P*L2-408, P*M2-390, P*M2-441, PAH2-433, PAH2-490, AND ALL 3, 4, 5, & 6 FAN P*U, P*L, P*M, PAH MODELS	FAN GUARD, AIR STRAIGHTENER (24" FANS)	10709900	430
	FAN GUARD, WIRE, EPOXY COATED, 24"	202136001	430

FOLLOWING MOTORS ARE FOR UNITS PRODUCED BEFORE APRIL 1, 1990.

ALL 1, 2, & 3 FAN P*M, AND PAH MODELS, & P*M4-780, P*M4-822, PAH4-866, PAH4-980, PAH4-1100	MOTOR, PSC, 1/3 HP, 1075 RPM, 115V (5 MFD CAPACITOR NOT INCLUDED)	205051005	NLA
	MOTOR, PSC, 115V, 1/3 HP, 1075 RPM, LO-GRSE (5 MFD CAP. NOT INCLUDED)	205051020	764
	MOTOR, PSC, 1/3 HP, 1075 RPM, 208-230/60/1 (5 MFD CAPACITOR NOT INCLUDED)	205051004	NLA
	MOTOR, PSC, 230V, 1/3 HP, 1075 RPM, LO-GRSE (5.0 MFD CAP. NOT INCLUDED)	205051019	865
	MOTOR, PSC, 1/3 HP, 1075 RPM, 460/60/1 (7.5 MFD CAPACITOR NOT INCLUDED)	205051006	NLA
P*U4-851, P*U4-1080, P*L4-1100, P*L4-1380 P*M4-1320, P*M4-1656, PAH4-1452, PAH4-1821	MOTOR, PSC, 3/4 HP, 1075RPM, 208-230/60/1 (5 MFD CAPACITOR NOT INCLUDED)	205051009	NLA
	MOTOR, PSC, 3/4 HP, 1075RPM, 208-230/60/1 (5 MFD CAPACITOR NOT INCLUDED)	118187000	1176
	MOTOR, PSC, 3/4 HP, 1075RPM, 460/60/1 (5 MFD CAPACITOR NOT INCLUDED)	205051002	NLA
	MOTOR, PSC, 3/4 HP, 1075RPM, 460/60/1 (5 MFD CAPACITOR NOT INCLUDED)	118186000	1348
	MOTOR, PSC, 3/4 HP, 1625 RPM, 208-230/60/1 (7.5 MFD CAPACITOR NOT INCLUDED)	205051007	954
ALL 1, 2, & 3 FAN P*U, AND P*L MODELS, AND P*U4-711, P*L4-722, P*L4-817	MOTOR, PSC, 3/4 HP, 1625 RPM, 460/60/1 (7.5 MFD CAPACITOR NOT INCLUDED)	205051008	1026
	MOTOR, PSC, 3/4 HP, 1625 RPM, 460/60/1 (7.5 MFD CAPACITOR NOT INCLUDED)	205051008	1026
ALL MODELS	MOTOR, MOUNT, 24"	205269000	206

NOTE: SOME MOTORS REQUIRE LOW TEMP GREASE, ASK FOR OPERATING TEMPERATURE.

FOLLOWING MOTORS ARE FOR UNITS PRODUCED AFTER APRIL 1, 1990.

ALL 1, 2, 3, FAN P*M, AND PAH MODELS, AND P*M4-780, P*M4-882, PAH4-866, PAH4-980, PAH4-1100	MOTOR, PSC, 115V, 1/3 HP, 1075 RPM (NO LONGER AVAILABLE FOR EVAP. UNITS)	205051005	NLA
	MOTOR, PSC, 115V, 1/3 HP, 1075 RPM, LO-GRSE (5 MFD CAP. NOT INCLUDED)	205051020	764
	MOTOR, ECM , 1/3 HP, 1075 RPM, CCW, 115V	08216130	847
	MOTOR, PSC, 230V, 1/3 HP, 1075 RPM (NO LONGER AVAILABLE FOR EVAP. UNITS)	205051004	NLA
	MOTOR, PSC, 230V, 1/3 HP, 1075 RPM, LO-GRSE (5.0 MFD CAP. NOT INCLUDED)	205051019	865
	MOTOR, ECM , 1/3 HP, 1075 RPM, CCW, 230V	08216131	1033
	MOTOR, PSC, 460V, 1/3 HP, 1075 RPM (NO LONGER AVAILABLE FOR EVAP UNITS)	205051006	NLA
P*U2-355, P*L2-361, P*L2-408, AND ALL 3, 4, 5, & 6 FAN P*U, AND P*L MODELS, P*M4-1100, P*M4-1320, P*M4-1656, P*M5-2065 P*M6-2480, PAH4-1452, PAH4-1821 PAH5-2275, PAH6-2730	MOTOR, PSC, 460V, 1/3 HP, 1075 RPM, LO-GRSE (7.5 MFD CAP. NOT INCLUDED)	205051021	932
	MOTOR, PSC, 1/3 HP, 1075 RPM, 575/60/1 (7.5 MFD CAPACITOR NOT INCLUDED)	115950000	887
	MOTOR, PSC, 3/4 HP, 1075RPM, 208-230/60/1 (NO LONGER AVAILABLE FOR EVAPS)	205051009	NLA
	MOTOR, PSC, 3/4 HP, 1075RPM, 208-230/60/1 (5 MFD CAPACITOR NOT INCLUDED)	118187000	1176
	MOTOR, PSC, 3/4 HP, 1075RPM, 460/60/1 (NO LONGER AVAILABLE FOR EVAP UNITS)	205051002	NLA
	MOTOR, PSC, 3/4 HP, 1075RPM, 460/60/1 (5 MFD CAPACITOR NOT INCLUDED)	118186000	1348
	MOTOR, PSC, 1/2 HP, 1075RPM, 575/60/1 (5 MFD CAPACITOR NOT INCLUDED)	115952000	841
P*U1-118, P*U2-236, P*L1-125, P*L1-152, P*L1-193, P*L2-240 P*L2-304	MOTOR, ECM , 3/4 HP, 1075 RPM, CCW, 230V	08216132	1333
	MOTOR, PSC, 3/4 HP, 1625 RPM, 208-230/60/1 (7.5 MFD CAPACITOR NOT INCLUDED)	205051007	954
	MOTOR, PSC, 3/4 HP, 1625 RPM, 460/60/1 (7.5 MFD CAPACITOR NOT INCLUDED)	205051008	1026
	MOTOR, PSC, 1/2 HP, 1075RPM, 575/60/1 (5 MFD CAPACITOR NOT INCLUDED)	115952000	841
ALL MODELS	MOTOR, ECM , 3/4 HP, 1625 RPM, CCW, 230V	08216133	1097
	MOTOR, MOUNT, 24"	205269000	206
ALL MODELS	CAPACITOR, 5 MFD	202163004	42
	CAPACITOR, 7.5 MFD	202163006	45

NOTE: SOME MOTORS REQUIRE LOW TEMP GREASE, ASK FOR OPERATING TEMPERATURE.

BOLD PART NUMBERS ARE FOR REPLACEMENT MOTORS

POWER-MAX, PMA, PME, PMG

MODEL NUMBER	DESCRIPTION	PART NUMBER	LIST PRICE
PMA 060-300, PME, G 044-225	MOTOR, 1/6 HP, 115/230/1 VOLT, 1/2 SHAFT, 1550 RPM, CW	NLA	—
PMA 400-900, PME, G 350 -760	MOTOR, 1/2 HP, 208-230/460/3, 5/8 SHAFT, 1125 RPM, REV	08216007	\$1,224
PMA 1100, 1370 PME, G 897, 1150	MOTOR, 1-1/2 HP, 208-230/460/3, 5/8 SHAFT, 1140 RPM, REV * ORIGINAL MOTOR, 1 HP	08216082	1493
PMA 060-176	FAN BLADE 14", 30° PITCH, CW, 1/2" BORE	NLA	—
PME, G 044-130	FAN GUARD, 14", WIRE, EPOXY COATED, BLACK	08397013	66
PMA 232, 300	FAN BLADE 16", 22° PITCH, CW, 1/2" BORE	08221020	115
	FAN GUARD, 16", WIRE, EPOXY COATED, BLACK	NLA	—
PME, G 168 225	FAN GUARD, 16", WIRE, EPOXY COATED, WHITE	08397055	94
PMA 400-900	FAN BLADE 22", 28° PITCH, CW, 5/8" BORE	08221023	119
PME, G 350-760	FAN GUARD, 22", WIRE, EPOXY COATED, BLACK	08397012	135
PMA 1100, 1370	FAN BLADE 26", 29° PITCH, CW, 5/8" BORE	08221047	98
PME, G 897, 1150	FAN GUARD, 26", WIRE, EPOXY COATED	08397010	139
ALL MODELS	FAN DELAY, DEFROST TERMINATION, THERMOSTAT, F25	204464037	325

ALL DEFROST HEATERS AND SHEET METAL PARTS ARE **NO LONGER AVAILABLE**.

FLEX TEMP-MODELS FT

MODEL NUMBER	DESCRIPTION	PART NUMBER	LIST PRICE
FT18-6, FT18-8	DRAIN PAN-VENTURI	20985600	\$124
	FAN BLADES, PLASTIC, 6" DIAM., 21° PITCH, CW, HUBLESS	105849001	51
	FAN GUARD, PLASTIC, 6"	205932000	80
	MOTOR, SKELETON FRAME, SHADED POLE, 43 WATT INPUT, 3000 RPM, 115 V.	102249005	148
	MOTOR, SKELETON FRAME, SHADED POLE, 43 WATT INPUT, 3000 RPM, 230 V.	102249007	148
FT28-12	DRAIN PAN-VENTURI	20985500	163
	FAN BLADES, PLASTIC, 6" DIAM., 21° PITCH, CW, HUBLESS	105849001	51
	FAN GUARD, PLASTIC, 6"	205932000	80
	MOTOR, SKELETON FRAME, SHADED POLE, 43 WATT INPUT, 3000 RPM, 115 V.	102249005	148
	MOTOR, SKELETON FRAME, SHADED POLE, 43 WATT INPUT, 3000 RPM, 230 V.	102249007	148
FT18-17	DRAIN PAN-VENTURI	20985400	197
	FAN BLADES, 8" DIAM., 31° PITCH, CW, HUBLESS	204395010	43
	FAN GUARD, PLASTIC, 8"	206569000	82
	MOTOR, SHADED POLE, 9 WATT, 1550 RPM, 115 V.	103104004	146
	MOTOR, SHADED POLE, 9 WATT, 1550 RPM, 230 V.	103104005	146
	MOTOR, ECM , 16W, 1550 RPM, 115V	107933006	616
	MOTOR, ECM , 16W, 1550 RPM, 230V	107933003	639
FT18-23, FT18-31	DRAIN PAN-VENTURI	20985300	250
	FAN BLADES, 10" DIAM., 25° PITCH, CCW	214022000	47
	FAN BLADES, REVERSE FLOW, 10" DIAM., 25° PITCH, CCW	12755	31
	FAN GUARD, WIRE, EPOXY COATED , 10", WHITE	08397053	88
	FAN GUARD, WIRE, EPOXY COATED , 10", BLACK	08397002	88
	MOTOR, SHADED POLE, 1/20 HP, 1550 RPM, 115 V.	102540003	189
	MOTOR, SHADED POLE, 1/20 HP, 1550 RPM, 208-230 V.	102540004	189
	MOTOR, ECM , 1/30 HP, 1550 RPM, 115V	08216126	720
	MOTOR, ECM , 1/30 HP, 1550 RPM, 230V	08216127	751

NLA - NO LONGER AVAILABLE

ASL MODELS

MODEL NUMBER	DESCRIPTION	PART NUMBER	LIST PRICE
ASL25-46E	DEFROST HEATERS, CORE, 1300 WATTS, 39" LENGTH, 230 V.	205221013	\$274
	DRAIN PAN, 46" LENGTH	20248901	411
ASL25-58E	DEFROST HEATERS, CORE, 1970 WATTS, 48" LENGTH, 230 V.	200172026	294
	DRAIN PAN	202489001	411
ASL35-70E	DEFROST HEATERS, CORE, 1850 WATTS, 62" LENGTH, 230 V.	205221016	430
	DRAIN PAN, 69" LENGTH	20248902	493
ASL45-94E	DEFROST HEATERS, CORE, 1250 WATTS, 42" LENGTH, 230 V. (2 REQ'D)	205221007	354
	DRAIN PAN, 92" LENGTH	20248903	546
ASL55-117E	DEFROST HEATERS, CORE, 1600 WATTS, 54" LENGTH, 230 V. (2 REQ'D)	205221010	406
	DRAIN PAN, 115" LENGTH	20248904	598
ALL "ASL" MODELS	DEFROST CONTROL, NON-ADJUSTABLE, 3 WIRE	103079002	122
ALL "ASL" MODELS	HEATER SAFETY SWITCH, 2 WIRE	103079003	111
ALL "ASL" MODELS	FAN BLADES, 10" DIAM., 31° PITCH, CW, HUBLESS, 1/4" BORE	204395018	47
ALL "ASL" MODELS	FAN GUARD, WIRE, EPOXY COATED, 10", WHITE	08397053	88
ALL "ASL" MODELS	FAN GUARD, WIRE, EPOXY COATED, 10", BLACK	08397002	88
ALL "ASL" MODELS	MOTOR MOUNT	10243000	88
ALL "ASL" MODELS	MOTOR, SHADED POLE, 16 WATT, 1550 RPM, 115 V.	103104007	174
	MOTOR, SHADED POLE, 16 WATT, 1550 RPM, 230 V.	103104008	174
ALL "ASL" MODELS	MOTOR, PSC, 16 WATT, 1550 RPM, 115 V.	107933001	354
	MOTOR, PSC, 16 WATT, 1550 RPM, 230 V.	107933003	NLA
ALL MODELS	MOTOR, ECM , 16 WATT, 1550 RPM, 115 V.	107933006	616
Electronically Commutated Motors	MOTOR, ECM , 16 WATT, 1550 RPM, 230 V.	107933003	639

ASLA & ASLE

ASLE 25-46	DEFROST HEATERS, CORE, 1300 WATTS, 39" LENGTH, 230 V.	205221013	\$274
	DRAIN PAN	202489001	411
ASLE 25-58	DEFROST HEATERS, CORE, 1970 WATTS, 48" LENGTH, 230 V.	200172026	294
	DRAIN PAN	202489001	411
ASLE 35-70	DEFROST HEATERS, CORE, 1850 WATTS, 62" LENGTH, 230 V.	205221016	430
	DRAIN PAN	202489002	493
ASLE 45-94	DEFROST HEATERS, CORE, 1250 WATTS, 42" LENGTH, 230 V. (2 REQ'D)	205221007	354
	DRAIN PAN	202489003	546
ASLE55-117	DEFROST HEATERS, CORE, 1600 WATTS, 54" LENGTH, 230 V. (2 REQ'D)	205221010	406
	DRAIN PAN	202489004	598
ALL "ASL" MODELS	DEFROST CONTROL, DEFROST TERMINATION, (TIMER RESET) 2 WIRE	08219241	122
ALL "ASL" MODELS	DEFROST CONTROL, FAN DELAY, 2 WIRE	103079009	122
ALL "ASLE" MODELS	HEATER SAFETY SWITCH, 2 WIRE	103079003	111
ALL "ASL" MODELS	FAN BLADES, 10" DIAM., 31° PITCH, CW, HUBLESS, 1/4" BORE	204395018	47
ALL "ASL" MODELS	FAN GUARD, WIRE, EPOXY COATED, 10", WHITE	08397053	88
ALL "ASL" MODELS	FAN GUARD, WIRE, EPOXY COATED, 10", BLACK	08397002	88
ALL "ASL" MODELS	MOTOR, SHADED POLE, 16 WATT, 1550 RPM, 115 V.	103104007	174
	MOTOR, SHADED POLE, 16 WATT, 1550 RPM, 230 V.	103104008	174
ALL "ASL" MODELS	MOTOR, PSC, 16 WATT, 1550 RPM, 115 V.	107933001	354
	MOTOR, PSC, 16 WATT, 1550 RPM, 230 V.	107933003	NLA
ALL MODELS	MOTOR, ECM , 16 WATT, 1550 RPM, 115 V.	107933006	616
Electronically Commutated Motors	MOTOR, ECM , 16 WATT, 1550 RPM, 230 V.	107933003	639

MINI TWIN AIR - MODELS MTW

MODEL NUMBER	DESCRIPTION	PART NUMBER	LIST PRICE
MTW18-8	DRAIN PAN (VENTURI)	20317800	\$160
MTW28-13	DRAIN PAN (VENTURI)	20317900	212
MTW28-18	DRAIN PAN (VENTURI)	20317900	212
MTW38-27	DRAIN PAN (VENTURI)	203176000	219
ALL "MTW" MODELS	FAN BLADES, 6" DIAM., 21° PITCH, CW, 1/4" BORE, PLASTIC	105849001	51
ALL "MTW" MODELS	FAN GUARD, PLASTIC, 6"	205932000	80
ALL "MTW" MODELS	MOTOR, SKELETON FRAME, SHADED POLE, 43 WATT INPUT, 3000 RPM, 115 V.	102249005	148
	MOTOR, SKELETON FRAME, SHADED POLE, 43 WATT INPUT, 3000 RPM, 230 V.	102249007	148

MULLION AIR - MODELS MUF, MDF, WAX

ALL 27-13, AND 27-17 MODELS	DRAIN PAN	20782200	\$124
ALL 37-23 MODELS	DRAIN PAN	20988300	151
ALL 27-13, AND 27-17 MODELS	FAN GUARD, 5" DIAM., 2 FAN MODELS	207824000	78
ALL 37-23 MODELS	FAN GUARD, 5" DIAM., 3 FAN MODELS	209885000	78
ALL MUF MODELS	FAN BLADES, 5" DIAM., CCW , PLASTIC	105849004	38
ALL MDF MODELS	FAN BLADES, 5" DIAM., CW, PLASTIC	105849002	38
ALL MODELS	MOTOR, SKELETON FRAME, SHADED POLE, 43 WATT INPUT, 3000 RPM, 115 V.	102249005	148
	MOTOR, SKELETON FRAME, SHADED POLE, 43 WATT INPUT, 3000 RPM, 230 V.	102249007	148

SLIM AIR - MODELS SL, AIR AND ELECTRIC DEFROST

SLE- ALL MODELS	DEFROST TERMINATION / FAN DELAY 3 WIRE NON-ADJUSTABLE	103079002	\$122
SL15-9E	DEFROST HEATER, CORE, 420 WATTS, 10" LENGTH, 115 V.	NLA	—
	DEFROST HEATER, CORE, 420 WATTS, 10" LENGTH, 230 V.	NLA	—
SL15-11E	DEFROST HEATERS, CORE, 500 WATTS, 14" LENGTH, 115 V.	NLA	—
	DEFROST HEATERS, CORE, 500 WATTS, 14" LENGTH, 230 V.	NLA	—
SL25-15E	DEFROST HEATERS, CORE, 700 WATTS, 17" LENGTH, 115 V.	NLA	—
	DEFROST HEATERS, CORE, 700 WATTS, 17" LENGTH, 230 V.	NLA	—
SL25-20E	DEFROST HEATERS, CORE, 900 WATTS, 24" LENGTH, 115 V.	NLA	—
	DEFROST HEATERS, CORE, 900 WATTS, 24" LENGTH, 230 V.	NLA	—
SL35-26E	DEFROST HEATERS, CORE, 1300 WATTS, 33" LENGTH, 115 V.	NLA	—
	DEFROST HEATERS, CORE, 1300 WATTS, 33" LENGTH, 230 V.	NLA	—
SL45-33E	DEFROST HEATERS, CORE, 1600 WATTS, 41" LENGTH, 115 V.	NLA	—
	DEFROST HEATERS, CORE, 1600 WATTS, 41" LENGTH, 230 V.	NLA	—
SL55-44E	DEFROST HEATERS, CORE, 2100 WATTS, 56" LENGTH, 115 V.	NLA	—
	DEFROST HEATERS, CORE, 2100 WATTS, 56" LENGTH, 230 V.	NLA	—
SL35-58E	DEFROST HEATERS, CORE, 2200 WATTS, 56" LENGTH, 230 V.	200172027	325
SL35-70E	DEFROST HEATERS, CORE, 1220 WATTS, 30 LENGTH, 230 V. (1 REQ'D)	200172023	305
	DEFROST HEATERS, CORE, 1760 WATTS, 42 LENGTH, 230 V. (1 REQ'D)	205221007	354
SL45-87E	DEFROST HEATERS, CORE, 1300 WATTS, 39 LENGTH, 230 V. (1 REQ'D)	205221013	274
	DEFROST HEATERS, CORE, 1970 WATTS, 48 LENGTH, 230 V. (1 REQ'D)	200172026	294
SL17-10, SL15-9E	DRAIN PAN	NLA	—
SL17-13, SL15-11E	DRAIN PAN	NLA	—
SL27-17, SL25-15E	DRAIN PAN	NLA	—
SL27-23, SL25-20E	DRAIN PAN	NLA	—
SL37-30, SL35-26E	DRAIN PAN	NLA	—
SL47-37, SL45-33E	DRAIN PAN	NLA	—
SL57-50, SL55-44E	DRAIN PAN	NLA	—
SL35-58E	DRAIN PAN	NLA	—
SL35-70E	DRAIN PAN	NLA	—
SL45-87E	DRAIN PAN	NLA	—
SL15-9(E) THRU SL55-44(E)	FAN BLADES, 6" DIAM., 21° PITCH, CW , 1/4" BORE, PLASTIC	105849001	51
SL35-58(E), SL35-70(E), SL45-87(E)	FAN BLADES, 10" DIAM., 31° PITCH, CCW , HUBLESS, 1/4" BORE	204395018	47
SL15-9(E) THRU SL55-44(E)	FAN GUARD, PLASTIC, 6"	205932000	80
SL35-58(E), SL35-70(E), SL45-87(E)	FAN GUARD, WIRE, EPOXY COATED, 10", WHITE	08397053	88
SL15-9(E) THRU SL55-44(E)	MOTOR, SKELETON FRAME, SHADED POLE, 43 WATT INPUT, 3000 RPM, 115 V.	102249005	148
	MOTOR, SKELETON FRAME, SHADED POLE, 43 WATT INPUT, 3000 RPM, 230 V.	102249007	148
SL35-58(E), SL35-70(E), SL45-87(E)	MOTOR, SHADED POLE, 16 WATT, 1550 RPM, 115 V.	103104007	174
	MOTOR, SHADED POLE, 16 WATT, 1550 RPM, 230 V.	103104008	174
SL15-9(E) THRU SL55-44(E)	MOTOR MOUNT, 43 WATT MOTORS	12003600	43
SL35-58(E), SL35-70(E), SL45-87(E)	MOTOR MOUNT, 16 WATT MOTORS	10243000	88

NLA - NO LONGER AVAILABLE

SLIM AIR - MODELS SLA

MODEL NUMBER	DESCRIPTION	PART NUMBER	LIST PRICE
SLA 17-10	DRAIN PAN (VENTURI)	20997400	\$160
SLA 17-13	DRAIN PAN (VENTURI)	20997600	176
SLA27-17	DRAIN PAN (VENTURI)	20997800	207
SLA27-23	DRAIN PAN (VENTURI)	20996600	244
SLA 37-30	DRAIN PAN (VENTURI)	20996800	289
SLA 47-40	DRAIN PAN (VENTURI)	20997000	319
SLA 57-50	DRAIN PAN (VENTURI)	20997200	395
ALL MODELS	FAN BLADES, 6" DIAM., 21° PITCH, CW, PLASTIC	105849001	51
ALL MODELS	FAN GUARD, PLASTIC,(CLEAR), 6"	205932000	80
ALL MODELS	MOTOR, SKELETON FRAME, SHADED POLE, 43 WATT INPUT, 3000 RPM, 115 V.	102249005	148
ALL MODELS	MOTOR, SKELETON FRAME, SHADED POLE, 43 WATT INPUT, 3000 RPM, 230 V.	102249007	148
ALL MODELS	MOTOR MOUNT	12003600	43

SLIM AIR - MODELS SLE

ALL "SLE" MODELS	DEFROST CONTROL, DEFROST TERMINATION, (TIMER RESET) 2 WIRE	103079010	\$122
ALL "SLE" MODELS	DEFROST CONTROL, FAN DELAY, 2 WIRE	103079009	122
ALL "SLE" MODELS	DEFROST CONTROL, DEFROST TERMINATION, FAN DELAY, 3 WIRE	103079002	122
SLE 15-9	DEFROST HEATER, 400 WATTS, 10-1/4" LENGTH, 115V.	220150001	206
	DEFROST HEATER, 400 WATTS, 10-1/4" LENGTH, 230V.	220150031	236
	DRAIN PAN	20997400	160
SLE 15-12	DEFROST HEATER, 500 WATTS, 14-1/4" LENGTH, 115V.	220150002	207
	DEFROST HEATER, 500 WATTS, 14-1/4" LENGTH, 230V.	220150032	240
	DRAIN PAN	20997600	176
SLE 25-16	DEFROST HEATER, 700 WATTS, 17-3/4" LENGTH, 115V.	220150003	239
	DEFROST HEATER, 700 WATTS, 17-3/4" LENGTH, 230V.	220150033	228
	DRAIN PAN	20997800	207
SLE 25-21	DEFROST HEATER, 700 WATTS, 17-3/4" LENGTH, 115V.	220150003	239
	DEFROST HEATER, 700 WATTS, 17-3/4" LENGTH, 230V.	220150033	228
	DRAIN PAN	20998000	244
SLE 25-28	DEFROST HEATER, 900 WATTS, 25-1/4" LENGTH, 115V.	220150004	264
	DEFROST HEATER, 900 WATTS, 25-1/4" LENGTH, 230V.	220150034	316
	DRAIN PAN	20998200	300
SLE 35-36	DEFROST HEATER, 1200 WATTS, 32-1/4" LENGTH, 115V.	220150005	293
	DEFROST HEATER, 1200 WATTS, 32-1/4" LENGTH, 230V.	220150035	343
	DRAIN PAN	20998400	332
SLE 45-54	DEFROST HEATER, 1500 WATTS, 42" LENGTH, 115V.	220150006	372
	DEFROST HEATER, 1500 WATTS, 42" LENGTH, 230V.	220150036	376
	DRAIN PAN	20998600	411
SLE 35-70	DEFROST HEATER, 2300 WATTS, 69-1/4" LENGTH, 230V.	220150037	422
	DEFROST HEATER, 2300 WATTS, 69-1/4" LENGTH, 115V.	220150007	350
	DRAIN PAN	20998800	454
SLE 15-9 THRU 25-16	FAN BLADES, 6" DIAM., 21° PITCH, CW, PLASTIC	105849001	51
	FAN GUARD, PLASTIC, (CLEAR), 6"	205932000	80
SLE 25-21 THRU 45-54	FAN BLADES, 8" DIAM., 31° PITCH, CCW	204395010	43
	FAN GUARD, PLASTIC, (CLEAR), 8"	206569000	82
SLE 35-70	FAN BLADES, 10" DIAM., 31° PITCH, CCW	204395018	47
	FAN GUARD, WIRE, EPOXY COATED, 10" (WHITE)	08397053	88
SLE 15-9 THRU 25-16	MOTOR, SKELETON FRAME, SHADED POLE, 43 WATT INPUT, 3000 RPM, 115 V.	102249005	148
	MOTOR, SKELETON FRAME, SHADED POLE, 43 WATT INPUT, 3000 RPM, 230 V.	102249007	148
SLE 25-21 THRU 45-54	MOTOR, SKELETON FRAME, SHADED POLE, 9 WATT, 1550 RPM, 115 V.	103104004	146
	MOTOR, SKELETON FRAME, SHADED POLE, 9 WATT, 1550 RPM, 230 V.	103104005	146
	MOTOR, ECM , 16 WATT, 1550 RPM, 115V	107933006	616
	MOTOR, ECM , 16 WATT, 1550 RPM, 208-230V	107933003	639
SLE 35-70	MOTOR, SKELETON FRAME, SHADED POLE, 16 WATT, 1550 RPM, 115 V.	103104007	174
	MOTOR, SKELETON FRAME, SHADED POLE, 16 WATT, 1550 RPM, 230 V.	103104008	174
SLE 15-9 THRU 25-16	MOTOR MOUNT	12003600	43
SLE 25-21 THRU 45-54	MOTOR MOUNT	12003000	47
SLE 35-70	MOTOR MOUNT	10243000	88

NLA - NO LONGER AVAILABLE

T TEMP - MODELS TT

MODEL NUMBER	DESCRIPTION	PART NUMBER	LIST PRICE
TT18-8	DRAIN PAN	20316400	\$160
TT28-13	DRAIN PAN	20316501	176
TT28-17	DRAIN PAN	20316502	207
ALL "TT" MODELS	FAN BLADES, 6" DIAM., 21° PITCH, CW , 1/4" BORE, PLASTIC	105849001	51
ALL "TT" MODELS	FAN GUARD, PLASTIC, (CLEAR), 6"	205932000	80
ALL "TT" MODELS	MOTOR, SKELETON FRAME, SHADED POLE, 43 WATT INPUT, 3000 RPM, 115 V.	102249005	148
ALL "TT" MODELS	MOTOR, SKELETON FRAME, SHADED POLE, 43 WATT INPUT, 3000 RPM, 230 V.	102249007	148
ALL "TT" MODELS	MOTOR MOUNT	12003600	43

TWIN TEMP - MODELS TW

TW17-9, TW17-12, TW17-18	DRAIN PAN	20870100	\$142
TW17-25, TW17-35	DRAIN PAN	20873500	142
TW17-45, TW17-55, TW18-65	DRAIN PAN	20874600	274
TW17-75, 18-85, TW17-105, TW18-120	DRAIN PAN	10574400	293
TW17-150,180	DRAIN PAN	NLA	—
TW17-9	FAN BLADES, 8" DIAM., 20° PITCH, CCW, HUBLESS	204395008	43
TW17-12, TW17-18	FAN BLADES, 8" DIAM., 31° PITCH, CCW , HUBLESS	204395010	43
TW17-25, TW17-35	FAN BLADES, 10" DIAM., 20° PITCH, CW , HUBLESS	204395016	47
TW17-45	FAN BLADES, 12" DIAM., 18° PITCH, CCW , 5/16" BORE	214118000	142
TW17-55	FAN BLADES, 12" DIAM., 23° PITCH, CCW , 5/16" BORE	08221169	68
TW18-65	FAN BLADES, 12" DIAM., 23° PITCH, CCW , 5/16" BORE	08221169	68
TW17-75, TW18-85, TW17-105, TW18-120	FAN BLADES, 16" DIAM., 16° PITCH, CCW , 1/2" BORE	11904	192
TW17-150, TW27-300	FAN BLADES, 18" DIAM., 18° PITCH, CCW , 1/2" BORE	NLA	—
TW17-180	FAN BLADES, 18" DIAM., 18° PITCH, CCW , 1/2" BORE	NLA	—
TW27-240	FAN BLADES, 16" DIAM., 23° PITCH, CCW , 1/2" BORE	NLA	—
TW17-9, TW17-12, TW17-18	FAN GUARD, PLASTIC, 8"	206569000	82
TW17-25, TW17-35	FAN GUARD, WIRE, EPOXY COATED , 10", (WHITE)	08397053	88
TW17-45, TW17-55, TW18-65	FAN GUARD, WIRE, EPOXY COATED , 12"	201006011	88
TW17-75, TW18-85, TW17-105, TW18-120, TW27-240	FAN GUARD, WIRE, EPOXY COATED , 16"	201006004	119
TW17-150, TW17-180, TW27-300	FAN GUARD, WIRE, EPOXY COATED , 18"	NLA	—
TW17-9, TW17-12	MOTOR, SHADED POLE, 4 WATT,1550 RPM, 115 V (USE 103104004)	NLA	—
	EVAP MTR, ECM , 16 W, 1550 RPM, 115v	107933006	616
TW17-18, TW17-25, TW17-35	MOTOR, SHADED POLE, 9 WATT, 1550 RPM, 115 V.	103104004	146
	MOTOR, SHADED POLE, 9 WATT, 1550 RPM, 230 V.	103104005	146
	MOTOR, ECM , 16 WATT, 1550 RPM, 115V	107933006	616
	MOTOR, ECM , 16 WATT, 1550 RPM, 208-230V	107933003	639
TW17-45, TW17-55, TW18-65	MOTOR, SHADED POLE, 1/20 HP, 1550 RPM, 115 V.	102540003	189
	MOTOR, SHADED POLE, 1/20 HP, 1550 RPM, 208-230 V.	102540004	204
	MOTOR, ECM , 1/30 HP, 1550 RPM, 115V	08216126	720
	MOTOR, ECM , 1/30 HP, 1550 RPM, 230V	08216127	751
TW17-75, TW18-85, TW17-105, TW18-120, TW27-240	MOTOR ASSEMBLY, 1/12 HP, 115/230 V.	08522774	714
	MOTOR, SHADED POLE, 1/12 HP, 1050 RPM, 230 V.	08216119	NLA
TW17-150, TW17-180, TW27-300	MOTOR, SHADED POLE, 1/6 HP, 1050 RPM, 115/230/1 V.	NLA	—
TW17-9, TW17-12	MOTOR MOUNT (SPECIFY UNIT MODEL AND SERIAL NUMBERS WHEN ORDERING)	NLA	—
TW17-18	MOTOR MOUNT (SPECIFY UNIT MODEL AND SERIAL NUMBERS WHEN ORDERING)	10870202	616
TW17-25	MOTOR MOUNT (SPECIFY UNIT MODEL AND SERIAL NUMBERS WHEN ORDERING)	10873801	639
TW17-35	MOTOR MOUNT (SPECIFY UNIT MODEL AND SERIAL NUMBERS WHEN ORDERING)	10873802	67
TW17-45	MOTOR MOUNT (SPECIFY UNIT MODEL AND SERIAL NUMBERS WHEN ORDERING)	10874700	38
TW17-55, TW18-65	MOTOR MOUNT (SPECIFY UNIT MODEL AND SERIAL NUMBERS WHEN ORDERING)	10874800	566
TW17-75 THRU TW17-180	MOTOR MOUNT (SPECIFY UNIT MODEL AND SERIAL NUMBERS WHEN ORDERING)	10019700	566
TW27-210 THRU TW27-240	MOTOR MOUNT (SPECIFY UNIT MODEL AND SERIAL NUMBERS WHEN ORDERING)	10101200	NLA
TW27-300	MOTOR MOUNT (SPECIFY UNIT MODEL AND SERIAL NUMBERS WHEN ORDERING)	10575000	NLA

NLA - NO LONGER AVAILABLE

WALL TEMP - MODELS WA

MODEL NUMBER	DESCRIPTION	PART NUMBER	LIST PRICE
WA17-6	DRAIN PAN (VENTURI)	105633001	\$141
	FAN BLADES, 8" DIAM., 20° PITCH, CCW , HUBLESS	204395008	43
	FAN GUARD, PLASTIC, 8"	206569000	82
	MOTOR, SHADED POLE, 4 WATT,1550 RPM, 115 V. (USE 103104004)	NLA	—
	MOTOR, ECM , 16 WATT, 1550 RPM, 115V	107933006	616
WA17-9	DRAIN PAN (VENTURI)	105633001	141
	FAN BLADES, 8" DIAM., 20° PITCH, CCW , HUBLESS	204395008	43
	FAN GUARD, PLASTIC, 8"	206569000	82
WA17-12, WA17-18	DRAIN PAN (VENTURI)	105633002	141
	FAN BLADES, 8" DIAM., 31° PITCH, CCW , HUBLESS	204395010	43
	FAN GUARD, PLASTIC, 8"	206569000	82
MOTORS: WA17-9 WA17-12, WA17-18	MOTOR, SHADED POLE, 9 WATT, 1550 RPM, 115 V.	103104004	146
	MOTOR, SHADED POLE, 9 WATT, 1550 RPM, 230 V.	103104005	146
	MOTOR, ECM , 16 WATT, 1550 RPM, 115V	107933006	616
	MOTOR, ECM , 16 WATT, 1550 RPM, 208-230V	107933003	639
WA17-25, WA17-35	DRAIN PAN (VENTURI)	105633003	165
	FAN BLADES, 10" DIAM., 20° PITCH, CCW , 5/16" BORE	204395016	47
	FAN GUARD, WIRE, EPOXY COATED, 10", (WHITE)	08397053	88
	MOTOR, SHADED POLE, 1/20 HP, 1550 RPM, 115 V.	08216072	189
	MOTOR, SHADED POLE, 1/20 HP, 1550 RPM, 230 V.	102540004	204
	MOTOR, ECM , 1/30 HP, 1550 RPM, 115V	08216126	720
	MOTOR, ECM , 1/30 HP, 1550 RPM, 230V	08216127	751
WA17-45	DRAIN PAN (VENTURI)	105633004	165
	FAN BLADES, 12" DIAM., 23° PITCH, CCW , 1/2" BORE	11860	142
	FAN GUARD, WIRE, EPOXY COATED, BLUE, 12"	201006011	88
	MOTOR ASSY., 1/12 HP, 115/230 V.	8522774	768
	MOTOR, SHADED POLE, 1/12 HP, 1050 RPM, 115 V.	NLA	—
	MOTOR, SHADED POLE, 1/12 HP, 1050 RPM, 230 V.	NLA	—

WEDGE TEMP - MODELS WE

WE17-12	DRAIN PAN (VENTURI)	20193200	274
	FAN BLADES, 8" DIAM., 31° PITCH, CCW , HUBLESS	204395010	43
	FAN GUARD, PLASTIC, 8"	206569000	82
	MOTOR, SHADED POLE, 4 WATT,1550 RPM, 115 V. (USE 103104004)	NLA	—
WE17-15	DRAIN PAN (VENTURI)	20193200	274
	FAN BLADES, 8" DIAM., 31° PITCH, CCW , HUBLESS	204395010	43
	FAN GUARD, PLASTIC, 8"	206569000	82
	MOTOR, SHADED POLE, 9 WATT, 1550 RPM, 115 V.	103104004	146
	MOTOR, SHADED POLE, 9 WATT, 1550 RPM, 230 V.	103104005	146
WE17-18	DRAIN PAN (VENTURI)	20193000	274
	FAN BLADES, 8" DIAM., 31° PITCH, CCW , HUBLESS	204395010	43
	FAN GUARD, PLASTIC, 8"	206569000	82
	MOTOR, SHADED POLE, 9 WATT, 1550 RPM, 115 V.	103104004	146
	MOTOR, SHADED POLE, 9 WATT, 1550 RPM, 230 V.	103104005	146
WE17-25	DRAIN PAN (VENTURI)	105633003	310
	FAN BLADES, 10" DIAM., 20° PITCH, CCW , HUBLESS	204395016	47
	FAN GUARD, WIRE, EPOXY COATED, 10"	8397053	88
	MOTOR, SHADED POLE, 9 WATT, 1550 RPM, 115 V.	103104004	146
	MOTOR, SHADED POLE, 9 WATT, 1550 RPM, 230 V.	103104005	146
WE17-35	DRAIN PAN (VENTURI)	20192400	310
	FAN BLADES, 10" DIAM., 31° PITCH, CCW , HUBLESS	204395018	47
	FAN GUARD, WIRE, EPOXY COATED, 10"	8397053	88
	MOTOR, SHADED POLE, 16 WATT, 1550 RPM, 115 V.	103104007	174
	MOTOR, SHADED POLE, 16 WATT, 1550 RPM, 230 V.	103104008	174
EC MOTORS: WE17-12, -15,-18, -25, -35	MOTOR, ECM , 16 WATT, 1550 RPM, 115V	107933006	616
	MOTOR, ECM , 16 WATT, 1550 RPM, 208-230V	107933003	639
WE17-45, WE18-55	DRAIN PAN (VENTURI)	20192400	332
	FAN BLADES, 12" DIAM., 23° PITCH, CCW , 5/16" BORE	08221169	68
	FAN GUARD, WIRE, EPOXY COATED, 12"	201006011	88
	MOTOR, SHADED POLE, 1/20 HP, 1550 RPM, 115 V.	08216072	189
	MOTOR, SHADED POLE, 1/20 HP, 1550 RPM, 230 V.	102540004	204
	MOTOR, ECM , 1/30 HP, 1550 RPM, 115V	08216126	720
	MOTOR, ECM , 1/30 HP, 1550 RPM, 230v	08216127	751

NOTE: CHECK "CS" FOR STYLE OF 1/20 HP MOTOR FOR WE-17-45, 18-55, AND 28-110

WE28-110	DRAIN PAN / VENTURI (220061 OR 220061BLK)	NLA	—
	FAN BLADES, 12" DIAM., 19° PITCH, CCW , 5/16" BORE	11860	142
	FAN GUARD, WIRE, EPOXY COATED, 12"	201006011	88
	MOTOR, SHADED POLE, 1/20 HP, 1550 RPM, 115 V.	102540001	189
	MOTOR, SHADED POLE, 1/20 HP, 1550 RPM, 230 V.	102540002	204

NLA - NO LONGER AVAILABLE

AIR COOLED CONDENSERS - Common Parts

MODEL NUMBER	DESCRIPTION	PART NUMBER	LIST PRICE
COMMON PARTS	Disconnect, thru the door, 30A	08218990	\$505
	Disconnect, thru the door, 60A	08218991	602
	Disconnect, thru the door, 80A	08218992	797
	Disconnect, thru the door, 100A	08218993	853
	Disconnect, thru the door, 30A, 18"/ 22" fans	08218379	399
	Contact, 3P, 25-30A, 24V control	08219028	86
	Contact, 3P, 25-30A, 115V control	08219002	86
	Contact, 3P, 25-30A, 208-230V control	08219018	93
	Contact, 3P, 25-30A, 460V control	08219012	96
	Contact, NEMA1,3P,27A,208-230V control	104461733	641
	Fan Cycling, Pressure, Standard, R12,R22,R404A,R134A	08219003	348
	Fan Cycling, Ambient, Standard, R12,R22,R404A,R134A	08219006	154
	Fan Cycling, Pressure, R410A	08219463	386
	P66, Single Tap, R22/R404	08219427	1024
	P66, Dual Tap, R22/R404	08219429	1603
	P66, Single Tap, R134A	08219437	909
	P66, Single Tap,R410A	08219461	1422
	P66,Dual Tap, R410A	08219462	1976
	Shut Off Valve (P66 and Pressure cycling)	08356559	161

SMALL AIR COOLED CONDENSERS - MODELS WDS

MODEL NUMBER	DESCRIPTION	PART NUMBER	LIST PRICE	
Models 001 thru 011	MOTOR, .33 HP, 1140RPM, 208-230/3/60/50	08216106	\$463	
	MOTOR, PSC, .33 HP, 1140RPM, 208-230/1/60/50	205051004	362	
	5 MFD CAPACITOR FOR MOTOR 205051004	202163004	42	
	FAN BLADE, 22" DIA., 28" PITCH, 5/8" bore.	08221154	119	
	MOTOR, PSC, .33 HP, 1140 RPM, 208-230/1/60/50 for use with P-66	08216008	574	
	15 MFD CAPACITOR FOR MOTOR 008216008	08352607	45	
	MOTOR, .33 HP, 1140 RPM, 460/3/60/50	08216107	769	
	MOTOR, PSC, .33 HP, 1140 RPM, 460/1/60/50 for use with P-66	08216009	590	
	15 MFD CAPACITOR FOR MOTOR 08216009	08352607	45	
	MOTOR, .25 HP, 850 RPM, 208-230/460/3/60/50	08216075	1085	
	MOTOR, PSC, .25 HP, 850 RPM, 208-230/1/60/50 (Cap. On motor)	08216076	919	
	MOTOR, TOTALLY ENCL., 1/2 HP, 1140 RPM, 208-230/460/3/60/50	08352607	45	
	MOTOR, PSC, TOT. ENCL., 1/2 HP, 1140 RPM, 208-230//460/1/60/50	08216081	870	
	MOTOR MOUNT FOR .33 HP MOTORS	08397056	184	
	MOTOR MOUNT FOR .25 HP MOTOR 08216075 & 08216046 WITH 22" FAN	08519019	184	
	MOTOR MOUNT FOR .25 HP MOTOR 08216075 & 08216046 WITH 18" FAN	08519022	184	
	FAN GUARD, 18" DIAM., EPOXY COATED WIRE.	08397011	113	
	FAN GUARD, 22" DIAM., EPOXY COATED WIRE.	08397012	135	
	MODELS 001 & 002	FAN BLADE, 18" DIAM., 34" PITCH, CW, 5/8" BORE (for 1140 RPM MTRS)	08221022	121
	MODELS 003 thru 011	FAN BLADE, 22" DIAM., 28" PITCH, 1/2" BORE (for 1140 RPM MTRS)	08221154	119
MODELS 001 & 002	FAN BLADE, 18" DIAM., 34" PITCH, CW, 1/28" BORE (for 850 RPM MTRS)	08221076	117	
MODELS 003 thru 009	FAN BLADE, 22" DIAM., 28" PITCH, 5/8" BORE. (for 850 RPM MTRS)	08221023	119	

LARGE AIR COOLED CONDENSERS - MODELS WDS/WDD

MODEL NUMBER	DESCRIPTION	PART NUMBER	LIST PRICE
1140 RPM MODELS 009 THRU 229	MOTOR, 1.5 HP, 1140 RPM, 208-230/460/3/60/50	110204000	\$1,493
	MOTOR, 1.5 HP, 1140 RPM, 575/3/60	118570001	2227
	MOTOR, TOTALLY ENCLOSED, 1.5 HP, 1140 RPM, 208/230/3/60/50	08216154	2501
	FAN BLADE, 30" DIAM., 24" PITCH, 4 BLADE, CW, 5/8 BORE	08221151	466
	MOTOR, 1.0 HP, 1140 RPM, 208-230/1/60/50 (USE WITH P-66 CONTROLLER)	08216098	2079
	30 MFD CAPACITOR FOR MOTOR 008216098 (USE WITH P-66 CONT)	08352555	66
	FAN BLADE, 30" DIAM., 21" PITCH, 3 BLADE, CW, 5/8 BORE (USE WITH P-66)	08221180	385
	MOUNT FOR 1140 RPM MOTORS ABOVE	08522568	412
	FAN GUARD, 30" DIAM., EPOXY COATED WIRE.	08221151	466
850 RPM MODELS 009 THRU 213	MOTOR, 1.5 HP, 850 RPM, 208-230/460/3/60/50	08216100	2079
	FAN BLADE, 30" DIAM., 31" PITCH, 5 BLADE, CW, 5/8 BORE (use with 08216100)	08221152	257
	MOTOR, 1.0 HP, 850 RPM, 208-230/460/3/60/50	114105000	2079
	MOTOR, 1.0 HP, 850 RPM, 575/3/60	114105002	2540
	MOTOR, 1.0 HP, 850 RPM, 380/3/60	114105001	2184
	FAN BLADE, 30" DIAM., 28" PITCH, 4 BLADE, CW, 5/8 BORE (for 1 HP's above)	08221151	466
	MOUNT FOR 850 RPM MOTORS ABOVE	08522568	412
FAN GUARD, 30" DIAM., EPOXY COATED WIRE.	08397044	191	
550 RPM MODELS 008 THRU 158	MOTOR, 1/3 HP, 550 RPM, 208-230/460/3/60/50	119226000	1151
	METAL FAN BLADE, 30" DIAM., 31" PITCH, 5 BLADE, CW, 5/8 BORE	08221152	257
	SWEPT WING FAN, 30" DIAM., 25" PITCH, CW, 1/2 BORE	08221181	466
	FAN BLADE, 30" FB II	121424000	655
	MOUNT FOR 550 RPM MOTORS ABOVE	08522568	412
	FAN GUARD, 30" DIAM., EPOXY COATED WIRE. (Not for FB II)	08397044	191
VSEC MODELS RDS011 THRU 250	FAN GUARD, 30" DIAM. FOR FB II FANS	119397000	124
	SHEET METAL STACK FOR FB II FANS	08518318	191
	ELECTRONICALLY COMMUTATED MOTOR & FAN ASSEMBLY, 460/3/60	08216161	7661
	ELECTRONICALLY COMMUTATED MOTOR & FAN ASSEMBLY, 208-230/3/60	C/F	C/F

AIR COOLED CONDENSERS, CDS, CDL

MODEL NUMBER	DESCRIPTION	PART NUMBER	LIST PRICE
ALL MODELS	CONTACTOR, 24 VOLT COIL	08219028	\$86
	CONTACTOR, 115 VOLT COIL	08219002	86
	CONTACTOR, 208-230 VOLT COIL	08219018	93
	CONTACTOR, 460 VOLT COIL	08219012	96
CDS 008 THRU 142 CDL 008 THRU 114	FAN CYCLING CONTROL, AMBIENT	08219006	154
	FAN CYCLING CONTROL, PRESSURE	08219003	348
	P-66 FAN SPEED CONTROL, SINGLE PORT	08219427	1024
CDS 001 THRU 012	SHUT OFF VALVE, 1/4", (FOR USE ON P-66 FAN SPEED CONTROL MOTOR ONLY)	08396559	97
	MOTOR, 1/2 HP, 208-230/460/3, 1125 RPM, REV, 5/8 SHAFT	08216007	1224
	MOTOR*, 1/2 HP, 208-230/460/1, 1075 RPM, PSC, 5/8 SHAFT	8216006*	698
CDS 015 THRU 142	MOTOR+, 1-1/2 HP, 208-230/460/3, 1140 RPM, REV, 5/8 SHAFT	8216082+	1493
	MOTOR*, 1 HP, 208-230/460/1, 1100 RPM, PSC, 5/8 SHAFT	8216024*	1229
CDS 001, 002	FAN BLADE, 18", 34° PITCH, 5/8" BORE, CW	08221022	121
	FAN GUARD, 18", WIRE EPOXY COATED	08397011	113
CDS 004, THRU 012	FAN BLADE, 22", 28° PITCH, 5/8" BORE, CW	08221023	119
	FAN GUARD, 22", WIRE, EPOXY COATED	08397012	135
CDS 015, THRU 142	FAN BLADE, 26", 29° PITCH, 5/8" BORE, CW	08221047	98
	FAN GUARD, 26", WIRE EPOXY COATED	08397010	139
CDL 001 THRU 009	MOTOR, 1/4 HP, 208-230/460/3, 825 RPM, REV, 5/8 SHAFT	08216075	1085
	MOTOR, 1/4 HP, 208-230/460/1, 825 RPM, PSC, 5/8 SHAFT	08216076	919
CDL 013 THRU 114	MOTOR+, 1-1/2 HP, 208-230/460/3, 1140 RPM, REV, 5/8 SHAFT	8216082+	1493
	MOTOR*, 1/2 HP, 208-230/460/1, 825 RPM, PSC, 5/8 SHAFT	08216077	NLA
	FAN BLADE, 26" 29° PITCH, 5/8 BORE, CW	08221047	98
	FAN GUARD, 26", WIRE, EPOXY COATED	08397010	139
CDL 001, 002	FAN BLADE, 18" 34° PITCH, 5/8 BORE, CW	08221022	121
	FAN GUARD, 18", WIRE, EPOXY COATED	08397011	113
CDL 003 THRU 009	FAN BLADE, 22" 28° PITCH, 5/8 BORE, CW	08221023	119
	FAN GUARD, 22", WIRE, EPOXY COATED	08397010	139

* DSC MOTOR MUST BE USED ON FAN SPEED CONTROL APPLICATION

+ORIGINAL MOTOR, 1HP, 8216020, NO LONGER AVAILABLE

AIR COOLED CONDENSERS, MODELS RCS, RCL, WCS, WFS, WFL

MODEL NUMBER	DESCRIPTION	PART NUMBER	LIST PRICE
ALL RCS, RCL MODELS	MOTOR, 1 HP, 208-230/460/1, PSC, 1100 RPM, 5/8 SHAFT, CW FOR USE WITH P-66 FAN SPEED CONTROL ONLY	08216024	\$1,229
	FAN BLADE, 26", 29° PITCH, CW, 5/8 BORE FOR USE WITH P-66 FAN SPEED CONTROL MOTOR ONLY	08221047	98
	FAN GUARD, 26", WIRE EPOXY COATED, FAN SPE FOR USE ON P-66 FAN SPEED CONTROL MOTOR ONLY	08397010	139
ALL MODELS	P-66 FAN SPEED CONTROL DUAL PORT	08219429	1603
	SHUT OFF VALVE, 1/4", (FOR USE ON P-66 FAN SPEED CONTROL MOTOR ONLY)	08396559	97
	FAN GUARD, 30" WIRE, EPOXY COATED	08397044	191
	CONTACTOR, 24 VOLT COIL	08219028	86
	CONTACTOR, 115 VOLT COIL	08219002	86
	CONTACTOR, 208-230 VOLT COIL	08219018	93
	CONTACTOR, 460 VOLT COIL	08219012	96
	FAN CYCLING CONTROL, AMBIENT	08219006	154
	FAN CYCLING CONTROL, PRESSURE	08219003	348
	SERV. KIT, 30" MTR MT, WC* COND.	08522568	412
RCS MODELS ONLY	MOTOR, 1-1/2 HP, 208-230/460/3, REV, 1140 RPM, 5/8 SHAFT	08216082	1493
	FAN BLADE, 30" 24° PITCH, 5/8 BORE, CW	08221151	466
RCL MODELS ONLY	MOTOR, 1-1/2 HP, 208-230/460/3, REV, 850 RPM, 5/8 SHAFT	08216083	1392
	FAN BLADE, 30" 31° PITCH, 5/8 BORE, CW	08211152	257
ALL WFS, WFL, MODELS WCS, WCL MODELS 013 THRU 022	MOTOR, 1HP, 208-230/460/1, PSC, 1100 RPM, 5/8 SHAFT, CW FOR USE WITH P-66 FAN SPEED CONTROL ONLY	08216098	2079
	FAN BLADE, 26", 29° PITCH, CW, 5/8 BORE FOR USE WITH P-66 FAN SPEED CONTROL MOTOR ONLY	08221047	98
	FAN GUARD, 26", WIRE EPOXY COATED, FAN SPE FOR USE WITH P-66 FAN SPEED CONTROL MOTOR ONLY	08397010	139
WCS, WFS ONLY 029 — 212	MOTOR, 1-1/2HP, 208-230/460/3, REV, 1140 RPM, 5/8 SHAFT, CW	110204000	1493
	MOTOR, 1-1/2HP, 575/3, REV, 1140 RPM, 5/8 SHAFT, CW	118570001	2227
	FAN BLADE, 30", 24° PITCH, CW, 5/8 BORE	08221151	466
WCL, WFL, ONLY 027 — 196	MOTOR, 1-1/2 HP, 208-230/460/3, REV, 825 RPM, 5/8 SHAFT, CW	08216100	2079
	FAN BLADE, 30", 31° PITCH, CW, 5/8 BORE	08221152	257

SMALL AIR COOLED CONDENSERS - MODELS WCS, WCL

MODEL NUMBER	DESCRIPTION	PART NUMBER	LIST PRICE
ALL MODELS	FAN BLADES, 22" DIAM., 29° PITCH, CW, 1/2" BORE	08221154	\$119
	FAN CYCLING CONTROL, PRESSURE	08219003	348
	FAN CYCLING CONTROL, AMBIENT	08219006	154
	P-66 FAN SPEED CONTROL, SINGLE PORT	08219427	1,024
	P-66 FAN SPEED CONTROL, DUAL PORT	08219429	1,603
	P-66 FAN SPEED CONTROL	08219437	909
	CONTACTOR, 24 VOLT COIL, 3 POLE	08219028	\$86
	CONTACTOR, 115 VOLT COIL, 3 POLE	08219002	86
	CONTACTOR, 208-230 VOLT COIL, 3 POLE	08219018	93
	CONTACTOR, 460 VOLT COIL, 3 POLE	08219012	96
	TRANSFORMER, 208-230 TO 24V	08218258	60
	TRANSFORMER, 480 TO 24V	08218259	63
	MOTOR MOUNT, 22"	08397056	184
WCS 001 THRU 012	MOTOR, PSC, 1/3 HP, 208-230/1, 1075 RPM, CW†‡	08216089	427
	MOTOR, PSC, 1/3 HP, 208-230/3, 1075 RPM, CW†‡	08216106	463
	MOTOR, PSC, 1/3 HP, 460/1, 1075 RPM, CW†‡	08216088	534
	MOTOR, PSC, 1/3 HP, 460/3, 1075 RPM, CW†‡	08216107	769
	MOTOR, PSC, 1/2 HP, 230-460/3, 1075 RPM, CW†‡	08216068	1,040
	MOTOR, PSC, 1/2 HP, 575/1, 1075 RPM, CW†‡	08216036	1,490
	CAPACITOR(LOOSE) 208-230 OR 460 MOTORS, 7.5 MFD	08216057	26
WCS 001 THRU 012	MOTOR, PSC, 1/2 HP, 208-230/460/1, 1075 RPM†	08216006	698
	MOTOR, REV, 1/2 HP, 208-230/460/3, 1125 RPM, 5/8 SHAFT†	08216007	1,224
WCL 001 THRU 011	MOTOR, REV, 1/4 HP, 208-230/3, 825 RPM, 5/8 SHAFT†	08216075	1,085
	MOTOR, PSC, 1/4 HP, 460/3, 825 RPM, 5/8 SHAFT†	08216076	919
WCS, WCL 001 THRU 002	FAN GUARD, WIRE, EPOXY COATED, 18"	08397011	113
	MOTOR RAIL 25" (18" FAN)	08519022	184
WCS, WCL 003 THRU 012	FAN GUARD, WIRE, EPOXY COATED, 22"	08397012	\$135
	MOTOR RAIL 30" (22" FAN)	08519019	\$184

† FOR USE WITH P-66 FAN SPEED CONTROL MOTOR ONLY

‡ CAPACITOR REQUIRED

AIR COOLED CONDENSERS, CDC

MODEL NUMBER	DESCRIPTION	PART NUMBER	LIST PRICE
006 THRU 055	MOTOR, 1/2 HP, 208-230/460/1, 1075 RPM, PSC, 5/8 SHAFT	08216006	\$698
	MOTOR, 1/2 HP, 208-230/460/3, 1125 RPM, REV, 5/8 SHAFT	08216007	1,224
080 THRU 690	MOTOR*, 1-1/2 HP, 208-230/460/3, 1140 RPM, REV, 5/8 SHAFT	08216082	1493
	FAN BLADE, 26", 29° PITCH, 5/8 BORE, CW	08221047	98
	FAN GUARD, 26", WIRE, EPOXY COATED	08397010	139
006, 012	FAN BLADE, 16", 34° PITCH, 5/8 BORE, CW	08221022	121
	FAN GUARD, 16", WIRE, EPOXY COATED	08397011	113
018 THRU 055	FAN BLADE, 22", 28° PITCH, 5/8 BORE, CW	08221023	119
	FAN GUARD, 22", WIRE, EPOXY COATED	08397012	135
036 THRU 690	FAN CYCLING CONTROL, AMBIENT	08219006	154
	FAN CYCLING CONTROL, PRESSURE	08219003	348
ALL MODELS	CONTACTOR, 115 VOLT COIL	08219002	86
	CONTACTOR, 208-230 VOLT COIL	08219018	93

*ORIGINAL MOTOR, 1 HP, #8216020, NO LONGER AVAILABLE

AIR COOLED CONDENSERS, WCE

550 RPM MODELS 017 THRU 152	MOTOR, 1/3 HP, 550 RPM, 208-230/460/3/60/50	119226000	1151
	METAL FAN BLADE, 30" DIAM., 31° PITCH, 5 BLADE, CW, 5/8 BORE	08221152	257
	SWEPT WING FAN, 30" DIAM., 25° PITCH, CW, 1/2 BORE	08221181	466
	FAN BLADE, 30" FB II	121424000	655
	MOUNT FOR 550 RPM MOTORS ABOVE	08522568	412
	FAN GUARD, 30" DIAM., EPOXY COATED WIRE. (Not for FB II)	08397044	191
	FAN GUARD, 30" DIAM. FOR FB II FANS	119397000	124
	SHEET METAL STACK FOR FB II FANS	08518318	191

PROLINE AIR COOLED CONDENSING UNITS, PWS, PWH, PWZ

ALL MODELS	LOW PRESSURE CONTROL, P70AB-Z	08219422	\$119
	HIGH PRESSURE CONTROL, P100CA-1D	08219424	46
	DUAL PRESSURE CONTROL, P70LB-22D	08219017	228
	DEFROST TIMER, PARAGON 8145-20	08219016	243
	OIL FAILURE CONTROL, P445NCB-22	08219200	534
<i>MODELS MANUFACTURED BEFORE MAY, 1997</i>			
PWS, PWH, 1/2 HP THRU 2-1/2 HP	MOTOR, 1/10 HP, 208-230, PSC, 1550 RPM, CCW	08216026	340
	FAN BLADE, 14", 30° PITCH, 5/16 BORE, CW	08221077	63
	MOTOR MOUNT	08515526	122
	MOTOR, 1/10 HP, 460, PSC, 1550 RPM, CW	08216040	NLA
<i>MODELS MANUFACTURED AFTER MAY, 1997</i>			
PWS, PWH 1/2 THRU 2-1/2 PWH 030L44, 038L44, 033E44	MOTOR, 1/20 HP, 208-230, SP, 1550 RPM, CW	08216071	189
	MOTOR, 1/20 HP, 460, SP, 1550 RPM, CW	08216034	280
	FAN BLADE, 12" 24° PITCH, 5/16 BORE, CCW	08221169	68
	MOTOR MOUNT	21062000	122
PWS, PWH 3 HP THRU 5 HP PWZ 2 HP THRU 6 HP	MOTOR, 1/3 HP, 208-230, PSC, 1075 RPM, CW	08216089	427
	CAPACITOR (LOOSE) 208-230 OR 460 MOTORS	08216062	32
	MOTOR, 1/3 HP, 460 PSC, 1075 RPM, CW	08216088	534
	FAN BLADE, 18", 38° PITCH, 5/16 BORE, CW	08221155	97
	FAN GUARD, 18" WIRE (INDOOR)	08397043	212
	MOTOR MOUNT (OUTDOOR)	08397047	179

PROLINE AIR COOLED CONDENSING UNITS (1/2 - 6 HP)

MODELS P*H, P*S, P*O, P*D, G*H, G*S, G*O, G*D

1/2 THRU 2 HP MODELS BUILT BEFORE 10/02	FAN BLADE, 12" DIAM., 24° PITCH, CW	08221153	\$71
	FAN GUARD, WIRE, EPOXY COATED, WHITE, 12" (INDOOR MODELS ONLY) †	201006010	88
	FAN GUARD, WIRE, EPOXY COATED, BLACK, 12" (INDOOR MODELS ONLY) †	08397040	88
	MOTOR, SHADED POLE, 1/20 HP, 1550 RPM, 230/1	08216071	189
	OUTDOOR HOUSING	OH-MC1	735
	MOTOR MOUNT (OUTDOOR MODELS)	21062000	122
"G" SERIES 1/2 THRU 3 HP MODELS BUILT 10 / 2002 AND AFTER	FAN BLADE, 12" DIAM., 24° PITCH, CCW	119103001	71
	FAN GUARD, WIRE, EPOXY COATED, 12" (INDOOR MODELS ONLY)	123334000	159
	GRILLE, WIRE, EPOXY COATED (OUTDOOR MODELS ONLY)	123064000	66
	FIXED LOW CUT OUT CONTROL - HIGH/MED TEMP MODELS (EXCEPT "CR" COMP'S)	204464232	285
	HIGH CUT OUT CONTROL	204464208	221
	MOTOR MOUNT (OUTDOOR MODELS)	21062000	122
	MOTOR, SHADED POLE, 1/20 HP, 1550 RPM, 230/1	08216071	189
	MOTOR, SHADED POLE, 1/20 HP, 1550 RPM, 460/1	102540005	280
	MOTOR, PSC, 1/20 HP, 1550 RPM, 230 V., (2 MFD CAPACITOR NOT INCLUDED)	8216112**	296
	MOTOR, ECM , 16 WATT, 1550 RPM, 230 V	107933003	639
2-1/2 THRU 3 HP MODELS BUILT BEFORE 4 / 2003	FAN BLADE, 20" DIAM., 18° PITCH, CW	214040000	256
	FAN GUARD, WIRE, EPOXY COATED, BLACK, 20" (INDOOR MODELS ONLY)	213484000	210
	MOTOR, SHADED POLE, 1/6 HP, 1050 RPM, 230/1 (UNITS BUILT BEFORE MAR. 31, 2001)	NLA	—
	MOTOR, PSC, 1/3 HP, 1075 RPM, 208-230/1 (UNITS BUILT AFTER MAR. 31, 2001)	205051004	362
	MOTOR, ECM , 1/3 HP, 1075 RPM, CCW, 230V	08216131	1033
ALL 4 THRU 6 HP MODELS AND 2 - 3 HP SCROLLS BUILT BEFORE 4 / 2003	FAN BLADE, 20" DIAM., 29° PITCH, CW‡	213156000	256
	FAN BLADE, 24" DIAM., 28° PITCH, CCW (G-SERIES ONLY)	213266000	293
	FAN GUARD, WIRE, EPOXY COATED, BLACK, 20" (INDOOR MODELS ONLY)	213484000	210
	MOTOR, PSC, 1/3 HP, 1075 RPM, 208-230/1	205051004	362
	MOTOR, PSC, 3/4 HP, 1075 RPM, 460/1	205051002	1,026
	MOTOR, ECM , 1/3 HP, 1075 RPM, CCW, 230V	08216131	1,033
	GRILLE, WIRE, EPOXY COATED, 30"	124027000	293
	CAPACITOR, 5 MFD, 230/460/1/60 MOTORS ONLY	202163004	42
	MOTOR MOUNT - WIRE, 24"	212837000	206
	MOTOR MOUNT - WIRE, 20" ‡	210225000	206
ALL MODELS 1/2 THRU 6 HP	ADJUSTABLE LOW CUT OUT CONTROL ‡ (STD ON "CR" COMP'S)	204464021	285
	HIGH CUT OUT CONTROL - ALL MODELS	204464208	221
	HIGH CUT OUT CONTROL‡	204464049	221
	RELAY - DELAY, 90 SEC, D.O.B., 230V	104799010	112
	SEQUENCING RELAY - R2, DPDT, 30 AMP, 208/240 V, "ICE CUBE RELAY"	104799020	213

NOTES: * - REPLACE WITH "E" = INDOOR, "C" = OUTDOOR, "L" = FLOODED OUTDOOR

† - NOT AVAILABLE FOR "P" REVISION MODELS

‡ - EXCLUDES "G" SERIES UNITS. SEE "P" SERIES FOR REPLACEMENT

"W" SERIES — CONDENSING UNITS

MODEL NUMBER	DESCRIPTION	PART NUMBER	LIST PRICE
WS/NS WH/NH 1/2HP THRU 2-½ HP	MOTOR 1/10 HP, 208-230/1, PSC, 1550 RPM, CCW	08216026	\$340
	FAN BLADE, 14", 30 PITCH, 5/16 BORE, CW	08221077	63
	MOTOR 1/10 HP, 460/1, PSC, 1550 RPM, CW	08216040	401
	FAN GUARD, 14" WIRE, EPOXY COATED	08397013	66
WS/NS, WH/NH, 1-½ HP THRU 2-½ HP	FAN CYCLING CONTROL, AMBIENT	08219027	NLA
WS/NS WH/NH 3 HP THRU 5 HP	MOTOR, 1/2 HP, 208-230/460/1, 1075 RPM, CW	08216006	698
	FAN BLADE, 22", 28° PITCH, 5/8 BORE, CW	08221023	119
	FAN GUARD, 22", WIRE, EPOXY COATED	08397013	66
	FAN CYCLING CONTROL, AMBIENT	08219027	NLA
ALL MODELS	DUAL PRESSURE CONTROL, RANCO 020-7041	08219017	228
	DEFROST TIMER, PARAGON 8145-20	08219016	243
	OIL FAILURE CONTROL, PENN P445NCB-22	08219200	534
	MOTOR MOUNT, (NA ON 3HP AND ABOVE)	08515526	122

"WD" SERIES — AIR COOLED CONDENSING UNITS (3-22 HP) PRIOR TO 1999

MODELS WS, WD, WH, NS, ND, NH

ALL MODELS	DUAL PRESSURE CONTROL	08219017	\$228
	DEFROST TIMER, PARAGON 8145-20	08219016	243
	OIL FAILURE CONTROL, AMBIENT	08219000	534
	FAN CYCLING CONTROL, AMBIENT	08219027	NLA
	MOTOR, PSC, 1/2 HP, 1075 RPM, 208-230/460/1	08216006	698
	FAN BLADE, 22" 28° PITCH, 5/8 BORE, CW	08221023	119
	FAN GUARD, 22", WIRE, EPOXY COATED	08397012	135

"WD" SERIES AIR COOLED COND. UNITS (3 THRU 22 HP) AFTER 1999

MODELS WDC, WDE, WDL, WDS

MODEL NUMBER	DESCRIPTION	PART NUMBER	LIST PRICE
3L22, 3L52, 3L44, 3L57, 4L22, 4L44, 4L57, 5L22, 5L52, 5L44, 5L57, 6M44, 6L22, 6L52, 6L44, 6L57, 7H22, 7M52, 7M44, 7M57, 8H22, 8M52, 8M44, 8M57, 8L22, 8L44, 8L57, 9L22, 9L52, 9L44, 9L57, 10L22, 10L52, 10L44, 10L57	MOTOR, PSC, 1/3 HP, 1075 RPM, 208-230/1 V. (CAPACITOR NOT INCLUDED)	205051004	\$362
	MOTOR, PSC, 3/4 HP, 1075 RPM, 460/1 V. (CAPACITOR NOT INCLUDED)	205051002	1026
5H22, 5M22, 5M44, 5M57, 10H22, 10M52, 10M44, 10M57, 12M44, 15H22, 15M52, 15L52, 15L22, 15L44, 15L57, 22L22, 22L52, 22L44, 22L57	MOTOR, ECM , 1/3 HP, 1075 RPM, CCW, 230V	08216131	1033
	CAPACITOR, 7.5 MFD, 230/1 V. MOTORS ONLY	202163006	45
	MOTOR, PSC, 3/4 HP, 1075 RPM, 208-230/1 V. (CAPACITOR NOT INCLUDED)	205051009	954
	MOTOR, PSC, 3/4 HP, 1075 RPM, 460/1 V. (CAPACITOR NOT INCLUDED)	205051002	1026
	MOTOR, PSC, 1/2 HP, 1075RPM, 575/1/60	115952000	841
	MOTOR, ECM , 3/4 HP, 1075 RPM, CCW, 230V	08216132	1333
	CAPACITOR, 5MFD, 230/1 V. MOTORS ONLY	202163004	42
ALL MODELS	CAPACITOR, 5MFD, 460/1 V. MOTORS ONLY	202163004	42
ALL MODELS	FAN BLADE, 24" DIAM., 28° PITCH, CCW, 1/2" HUB	213266000	293
ALL MODELS	MOTOR MOUNT / FAN GUARD COMBINATION	204340000	210
ALL MODELS	HI-LO PRESSURE CONTROL	204464041	533
ALL MODELS	OIL FAILURE CONTROL	204464009	552

"WV" SERIES — AIR COOLED CONDENSING UNITS (20 THRU 80 HP)

ALL MODELS	FAN BLADES, 30" DIAM., 24° PITCH, CW, 5/8" BORE	210385000	\$466
ALL MODELS	FAN GUARD, WIRE, EPOXY COATED, 30"	202136006	561
ALL MODELS	MOTOR, 1-1/2 HP, 1140RPM, 208-230/460/60/3	110204000	1493
ALL MODELS	MOTOR, 1-1/2 HP, 1140RPM, 575/3	118570000	2227
ALL MODELS	MOTOR MOUNT, 30"	1252150010	412

MISCELLANEOUS SPARE PARTS

DESCRIPTION	PART NUMBER	LIST PRICE
THERMOSTAT, AMBIENT FAN CYCLE	204464002	412
3/4" BRASS DRAIN FITTING	102938025	NLA
SLINGER SHIELD - 1/2" SHAFT	102548002	42
SLINGER SHIELD - 5/8" SHAFT	102548001	46
CONTACTOR, 25 AMP, 3 POLE, 208-230/460	104461097	402
CONTACTOR, 30 AMP, 3 POLE, 208-230/460	104461098	424
CONTACTOR, 40 AMP, 3 POLE, 208-230/460	104461099	486
CONTACTOR, 50 AMP, 3 POLE, 208-230/460	104461111	603
CONTACTOR, 75 AMP, 3 POLE, 208-230/460	104461115	1050

NLA - NO LONGER AVAILABLE

APEX REFRIGERATION SYSTEM, XN, XT

MODEL NUMBER	DESCRIPTION	PART NUMBER	LIST PRICE
XN026M THRU XN037M, XN018L	CONDENSER AND EVAP. MOTOR, PSC, 16W, 1550 RPM, 115V	107933001	\$354
	CAPACITOR FOR THIS MOTOR, 5µF, 440V	202163004	42
	EVAPORATOR MOTOR, SP, 16W, 1550 RPM, 115V	103104007	174
	EVAPORATOR MOTOR, ECM, 16W, 1550 RPM, 115V	107933006	616
XN050M, XN024LE	CONDENSER AND EVAP. MOTOR, PSC, 1/20 HP, 1550 RPM, 115V	08216074	259
	CAPACITOR FOR THIS MOTOR, 3µF, 370V	202163010	40
	EVAPORATOR MOTOR, SP, 1/20 HP, 1550 RPM, 115 VOLT	08216072	189
	EVAPORATOR MOTOR, ECM, 50 W, 1550 RPM, 115 VOLT	08216124	579
X*050M THRU X*134M, X*024L THRU X*068L	CONDENSER AND EVAPORATOR MOTOR, 208-230V, 1/20 HP, 1550 RPM, PSC	08216073	296
	CAPACITOR FOR THIS MOTOR, 2µF, 370V	202163009	45
	EVAPORATOR MOTOR, SP, 1/20 HP, 1550 RPM, 208-230/1	08216071	204
	EVAPORATOR MOTOR, ECM, 50 W, 1550 RPM, 208-230/1	08216125	610
XN026M THRU XN037M, XN018L	CONDENSER MOTOR MOUNT	10243000	117
	EVAPORATOR MOTOR MOUNT	12003000	121
X*050M THRU X*134M, X*024L THRU X*068L	CONDENSER FAN, 12 INCH DIAM., 23° PITCH, CCW	08221169	68
	CONDENSER AND EVAPORATOR MOTOR MOUNT (FOR SP & PSC MOTORS)	21062000	122
	CONDENSER AND EVAPORATOR MOTOR MOUNT LEG (FOR ECM, 3 LEGS REQUIRED PER MOTOR)	08522938	38
XN026M THRU XN037M, XN018L	CONDENSER FAN, 10 INCH DIAM., 31° PITCH, CCW	204395018	47
X*050M THRU X*134M, X*024L THRU X*068L	CONDENSER FAN, 12 INCH DIAM., 23° PITCH, CCW	08221169	68
XN026M THRU XN037M, XN018L	EVAPORATOR FAN, 8 INCH DIAM., 36° PITCH, CCW	08221167	40
X*050M THRU X*134M, X*024L THRU X*068L	EVAPORATOR FAN, 10 INCH DIAM., 31° PITCH, CW (SP & PSC MOTORS)	08221168	43
	EVAPORATOR FAN, 10 INCH DIAM., 30° PITCH, CW (EC MOTORS)	08221174	43
ALL	HIGH PRESSURE CONTROL, 400 PSIG	08219424	87
XT050M THRU XT134M, XT024L THRU XT068L	CONDENSER MOTOR PRESSURE CONTROL	08219417	350
XT106M AND XT134M, XT051L AND 068L	CONDENSER MOTOR TEMPERATURE CONTROL	08219019	68
XN018L THRU X*068L	DEFROST HIGH LIMIT THERMOSTAT	103079003	111
XN050M AND XN024L	EVAPORATOR MOTOR RELAY, 115 VOLT COIL	08218979	45
X*050M THRU X*134M, X*024L THRU X*068L	EVAPORATOR MOTOR RELAY, 208-230 VOLT COIL	08218181	48
XN026M THRU XN037M, XN018L	COMPRESSOR CONTACTOR, 115 VOLT COIL	08218979	45
XN050M AND XN024L	COMPRESSOR CONTACTOR, 115 VOLT COIL	08219002	86
X*050M THRU X*134M, X*024L THRU X*068L	COMPRESSOR CONTACTOR, 208-230 VOLT COIL	08219018	93
ALL 115 VOLT FREEZERS	ELECTRONIC CONTROLLER , PROGRAMMED - LOW TEMP	08522796	\$584
ALL 208-230 VOLT FREEZERS	ELECTRONIC CONTROLLER, PROGRAMMED- LOW TEMP	08522797	\$584
ALL 115 VOLT COOLERS	ELECTRONIC CONTROLLER , PROGRAMMED - HIGH TEMP	08522798	\$584
ALL 208-230 VOLT COOLERS	ELECTRONIC CONTROLLER, PROGRAMMED - HIGH TEMP	08522799	\$584
ALL	ELECTRONIC COMTROLLER BOX AND DEFROST TEMPERATURE SENSOR	08219958	67
ALL	LATCHES FOR EVAPORATOR COVER	08326021	23
ALL	GASKET FOR TOP AND BOTTOM OF EVAPORATOR SECTION (ORDER/ FT)	08343051	16
XN018L	DEFROST HEATER, COIL, 400 WATTS, 22.5" LONG, 120 VOLT	08215137	239
XN024L	DEFROST HEATER, COIL, 375 WATTS, 26.5" LONG, 120 VOLT	08215144	220
X*024L THRU THRU X*043L	DEFROST HEATER, COIL, 375 WATTS, 26.5" LONG, 240 VOLT	08215138	241
X*051L AND X*068L	DEFROST HEATER, COIL, 600 WATTS, 40.5" LONG, 240 VOLT	08215139	338
XN018L	DEFROST HEATER, DP, 400 WATTS, 19.5" LONG, 120 VOLT	08215140	221
XN024L	DEFROST HEATER, DP, 500 WATTS, 22.0" LONG, 120 VOLT	08215145	230
X*024L THRU THRU X*043L	DEFROST HEATER, DP, 500 WATTS, 22.0" LONG, 240 VOLT	08215141	246
X*051L AND X*068L	DEFROST HEATER, DP, 600 WATTS, 35.0" LONG, 240 VOLT	08215142	293
XT050M THRU XT134M, XT024L THRU XT068L	DRAIN LINE HEATER	08215143	151
XT050M THRU XT134M, XT024L THRU XT068L	DRAIN LINE THERMOSTAT	103079003	111

** REQUIRES THE PURCHASE OF A NEW MOTOR MOUNT (21062000) TO FIT THE MOTOR

MOTOR HP	VOLT	PH.	RPM	MODEL APPLICATION	PART NUMBER	LIST PRICE	SHPG WT LBS
43 WATTS (INPUT) CW ROTATION	115V	1	3000	FT, MDF, MUF, MTW, SL, TT	102249005	\$148	2
	230 V	1	3000		102249007	148	2
4 WATTS	115V	1	1550	HI, TW, WA, WE	103104002	121	2
9 WATTS	115V	1	1550	FT, HI, TW, WA, WE	103104004	146	2
	230V	1	1550	FT, HI, TW, WA, WE	20192600	146	2
16 WATTS (ALL ANGLE)	115 V	1	1550	DFA, DFE, FL, FT, SL, ASL, WE	103104007	174	4
	230 V	1	1550		103104008	174	3
16 WATTS PSC (OPTIONAL no cap.)	115 V	1	1550	DFA, DFE, FL, SL, ASL, WE	107933001	354	4
	230 V	1	1550		107933002	NLA	—
1/20HP SHADED POLE	115 V	1	1550	SUPER TEMP	102540003	189	3
	230 V	1	1550	&	102540004*	189	3
	230 V	1	1550	PROLINE G-SERIES 1/2 - 2 HP	102540004	204	3
	460 V	1	1550		102540005	280	3
1/20HP PSC (OPTIONAL)	115 V	1	1550	SUPER TEMP	108178001	259	4
	230 V	1	1550		108178002	296	4
	230 V	1	1550	PROLINE G-SERIES 1/2 - 2 HP	108178002	296	4
1/20HP SHADED POLE	115 V	1	1550	HI, TW, WA, WE	102540001	189	3
	230 V	1	1550		102540002	204	3
1/15 HP SHADED POLE	115 V	1	1050	INTER FLO Prior to April, 1994	NLA	—	—
	460 V	1	1050		NLA	—	—
1/12HP SHADED POLE	115 / 230 V	1	1050	HI, TW, WA, RAC	08216119	530	8
1/8 HP PSC	115 V	1	1075	INTER FLO after March, 1996	115248001	704	11
	230 V	1	1075	(between 4/94 & 3/96 see page 9)	115248002	704	11
	460 V	1	1075		115248003	748	11
	460 V	1	1075		115248003	748	11
1/6 HP SHADED POLE	115/230V	1	1050	SU, HI, TW, RAC, GE, GC, GS, PROLINE 3 HP	102542007 08216025	NLA NLA	— —
1/3 HP PSC	115 V	1	1075	SU Hi-Cap, PA,	205051005	680	12
	230 V	1	1075	PROLINE 4-6 HP	205051004	362	12
	460 V	1	1075	SU, PA	205051006	804	12
1/3 HP PSC LO-GREASE	115 V	1	1075	INTER-FLO, POLAR-FLO	205051020	764	12
	230 V	1	1075		205051019	865	12
	460 V	1	1075		205051021	932	12
1/3 HP	230/460 V	3	550	VRQ	119226000	1,151	13
3/4HP PSC	230 V	1	1075	WDE, WDS	205051009	954	18
	460 V	1	1075		205051002	1,026	17
3/4HP PSC	230 V	1	1075	VARI SPEED	205051015	1,140	20
	460 V	1	1075		205051016	1,234	20
3/4HP PSC	208-230 V	1	1625	POLAR-FLO	205051007	954	18
	460 V	1	1625		205051008	1,026	17
3/4HP	230/460 V	3	1725	POLAR-FLO	123123000	1,031	18
3/4HP LO-GREASE	230/460 V	3	1725	POLAR-FLO	125101000	1,864	18
3/4HP PSC LO-GREASE	208-230 V	1	1075	POLAR-FLO	118187000	1,176	18
	460 V	1	1075		118186000	1,348	17
1 HP	230/460 V	3	850	VEQ	114105000	2,079	24

NLA - NO LONGER AVAILABLE

PRINCIPAL TERMS AND CONDITIONS OF SALE

1. **Applicable Law and Terms of Sale:** All orders shall be subject to the following terms and conditions notwithstanding any additional or contrary printed terms and conditions of Buyer. Such additional or contrary terms shall not bind Seller unless accepted in writing even though such terms do not materially alter the terms hereof. No oral statements, warranties, stipulations, representations or terms shall have any binding effect or be any part of the contract whatsoever.
2. **Orders:** All orders must be in writing and will be binding when our order acknowledgment is mailed. Orders are accepted subject to strikes, fires, accidents, and other causes beyond our reasonable control. Acceptance of your order is conditioned upon an agreement to hold us harmless by reason of delivery delays.
3. **Prices:** Prices are subject to change without notice, and all quotations, unless otherwise specified, are binding only for immediate acceptance. Prices are based on material made to Seller's standard tolerances, unless otherwise specified.
4. **Freight:** All products are shipped FOB Point of Shipment. Routing and selection of carrier will be made by Seller. For special routing requests, Buyer will bear all additional costs for such routing. Equipment is shipped at Buyer's risk. Buyer should examine equipment before signing transportation receipt. If equipment is received damaged or if quantity received does not match freight bill, the Buyer should require agent to so indicate on freight bill and immediately file a damage/missing claim. Our liability ceases upon delivery of equipment in good order to the freight carrier.
5. **Taxes:** Any sales, use, excise, or similar tax payable by Seller which is or may be imposed by any taxing authority upon manufacture, sale or delivery of goods covered by any order or any increase in rate of any such tax now in force, shall be added to the sales price; if not collected at the time of payment of sales price, Buyer will hold Seller harmless.
6. **Limited Warranty:** Seller warrants against defect in materials and workmanship in products which it manufactures for (1) year from date of installation or up to (18) eighteen months from the date of shipment, whichever event occurs first, when properly installed and operated under normal use. This guarantee does not include any labor or other charges made outside of the Seller's factory for replacement or repair of defective parts unless specifically stated in the body of the Sellers invoice. On parts not manufactured by Seller, such as motors, controls, valves and compressors we extend to the Buyer the same warranties made to us by the manufacturer. Sellers only liability under this warranty or otherwise shall be the repair or replacement (at Seller's option) of non-conforming goods or parts. Seller assumes no liability for incidental or consequential damages such as injury to person or property, or lost profits.
7. **THIS GUARANTEE SUPERSEDES AND IS IN LIEU OF ANY AND ALL OTHER WARRANTIES BY LAW OR CUSTOM, EITHER EXPRESSED OR IMPLIED INCLUDING, BUT NOT LIMITED BY THIS ENUMERATION, ANY GUARANTEE AS TO QUALITY OR FITNESS FOR ANY PARTICULAR PURPOSE, EXCEPT AS SET FORTH ABOVE. NO PERSON, AGENT, OR DEALER IS AUTHORIZED TO GIVE ANY WARRANTIES ON BEHALF OF SELLER NOR TO ASSUME FOR SELLER ANY OTHER LIABILITY IN CONNECTION WITH ANY OF THE SELLER'S PRODUCTS.**
8. **Delivery:** Seller shall not be liable for any delays in or failure of delivery due to acts of God or public authority, labor disputes, accidents, fires, floods, extreme weather conditions, failure of and delays by carriers, shortages of material, delays of a supplier, and any other cause beyond Seller's control. In no event shall Seller be liable for consequential or special damages arising out of a delay in or failure of delivery. Failure to meet estimated ship dates will not be considered sufficient cause of cancellation of orders.
9. **Cancellations and Returned Goods:** Permission to return any part or product must be obtained from Seller and may be subject to a restocking charge. Credits for new material accepted for return will be at the original sales price or current market price, whichever is lower, less handling and restocking charges. Buyer must prepay all transportation charges. Any costs for putting material in condition for resale will be charged to the Buyer. Shipment of material returned without factory authorization or not properly tagged with a Return Material Authorization Number or not freight prepaid cannot be received by Seller. Obsolete products or material made to special order are not returnable.
10. **Catalog Materials and Drawings:** Seller is not responsible for typographical errors or other errors of omission in Seller's catalogs or drawings.
11. **Late Charge Provision:** Buyer agrees to pay a late charge of 1-1/2% per month (18% per year) for any invoice or bill not paid within (30) thirty days of the date of the billing invoice.
12. **Choices of law, Disputes:** This agreement and the performance of the parties hereunder shall be construed in accordance with and governed by the laws of the State of California and shall be deemed made in the state. Buyer irrevocably consents to the exclusive jurisdiction of the courts of Orange County, California, on all matters arising out of or relating to this sale and Buyer further irrevocably consents to service of process by certified mail, return receipt requested, at Buyers address set forth in the order acknowledgement.

The above terms and conditions apply to all orders placed with the Seller. Buyer acknowledges having read and understood these terms and conditions and agrees to abide by them upon placement of any order with the Seller. In the event it becomes necessary to refer the account to a collection agency or to institute legal action to obtain payment of the account, Buyer agrees to pay all reasonable attorney fees and court costs incurred by such action.

