



Supersedes all earlier versions

LIST PRICES

Prices effective 7/2/18

All products, except surface coils and parts, are shipped F.O.B. point of shipment with full freight allowed on single orders with a net price value of \$10,000 or more, within the continental USA (excluding Alaska and Hawaii). Buyer will bear all additional costs for special routing or handling requests. See page 44 additional freight instructions.

Table with 2 columns: Product Category and Page. Categories include Reach-In Unit Coolers, Walk-In Unit Coolers, Condensing Units, and Air Cooled Condensers.

Due to ongoing product development, specification and prices are subject to change without notice.

ASL SPECIAL UNIT COOLERS

COOLER APPLICATION - AIR DEFROST

AIR DEFROST MODEL NUMBER	EC MOTORS	PSC MOTORS	SP MOTORS	RUSS PROOF MODEL NUMBER	RUSS PROOF COIL w/ ECM	RUSS PROOF COIL w/ PSC	RUSS PROOF COIL w/ SP	DIMENSIONS			SHIP WT. (LBS)
	115 or 230V	115V only	115 or 230V		115 or 230V	115 or 230V	115V only	115 or 230V	HT (IN)	LT (IN)	
ASLA 25-48	\$3,277	\$2,423	\$2,312	ASLA 25-48RP	\$4,384	\$3,637	\$3,253	9-3/16	46-3/16	19-3/16	83
ASLA 25-61	3,373	2,773	2,364	ASLA 25-61RP	4,449	3,686	3,337	9-3/16	56-3/16	19-3/16	105
ASLA 35-73	3,616	2,826	2,418	ASLA 35-73RP	4,791	3,866	3,390	9-3/16	69-3/16	19-3/16	125
ASLA 45-98	4,343	3,337	2,819	ASLA 45-98RP	5,459	4,340	3,902	9-3/16	92-3/16	19-3/16	151
ASLA 55-122	5,092	3,855	3,218	ASLA 55-122RP	6,214	4,873	4,375	9-3/16	115-3/16	19-3/16	185
ASLA 65-158	5,786	4,325	3,576	ASLA 65-158RP	6,989	5,211	4,828	9-3/16	138-3/16	19-3/16	222

Specify voltage when ordering - add an "A" for 115V and "D" for 230V. See example below.
230V PSC motors are not available for ASLA or ASLE models



For normal and low temperature glass display and solid door uprights, walk-ins salad boxes and back bars from 4,600 to 15,800 BTUH.

FREEZER APPLICATION - ELECTRIC DEFROST

ELECTRIC DEFROST MODEL NUMBER	230V EC MOTORS 230V1 HEATERS	230V/1 w/ SP MOTORS and 230V1 HEATERS	DIMENSIONS			SHIP WT. (LBS)
			HT (IN)	LT (IN)	DP (IN)	
ASLE 25-46	\$3,505	\$2,607	9-3/16	46-3/16	19-3/16	83
ASLE 25-58	\$3,668	2,684	9-3/16	56-3/16	19-3/16	105
ASLE 35-70	\$3,943	2,809	9-3/16	69-3/16	19-3/16	125
ASLE 45-94	\$4,729	3,507	9-3/16	92-3/16	19-3/16	151
ASLE 55-117	\$5,505	4,312	9-3/16	115-3/16	19-3/16	185
ASLE 65-150	\$6,244	4,703	9-3/16	138-3/16	19-3/16	222

\$332 List adder for adjustable termination/fan delay control in lieu of a fixed controls.
230V PSC motors are not available for ASLA or ASLE models

SLIM TEMP UNIT COOLERS

Space saving design for reach-ins, salad bars, back bars, etc. from 900 to 7,000 BTUH.



COOLER APPLICATION

MODEL NUMBER	UNCOATED CORE		RUSS PROOF MODEL NO.	RUSS PROOF COIL		DIMENSIONS			SHIP WT. (LBS)
	115V	230V		115V	230V	HT (IN)	LT (IN)	DP (IN)	
SLA 17-10	\$691	\$722	SLA 17-10RP	\$760	\$799	4-3/4	16-1/2	13-1/2	15
SLA 17-13	888	956	SLA 17-13RP	957	1,024	4-3/4	20-1/2	13-1/2	18
SLA 27-17	1,042	1,118	SLA 27-17RP	1,093	1,168	4-3/4	24	14-1/2	22
SLA 27-23	1,300	1,359	SLA 27-23RP	1,394	1,456	4-3/4	31-1/2	14-1/2	29
SLA 37-30	1,590	1,723	SLA 37-30RP	1,718	1,837	4-3/4	40	14-1/2	37
SLA 47-40	2,167	2,338	SLA 47-40RP	2,310	2,471	4-3/4	53-1/2	14-1/2	45
SLA 57-50	2,802	2,990	SLA 57-50RP	2,972	3,155	6-3/4	53-1/2	14-1/2	61

Specify voltage when ordering - add an "A" for 115V and "D" for 230V.

No EC or PSC motors for SLA models.

FREEZER APPLICATION - ELECTRIC DEFROST

MODEL NUMBER	SINGLE SPEED EC MOTORS		SHADED POLE MOTORS		DIMENSIONS			SHIP WT. (LBS)
	115V	230 V	115V	230V	HT (IN)	LT (IN)	DP (IN)	
SLE 15-9	N/A	N/A	\$1,141	\$1,141	4-3/4	16-1/2	13-1/2	16
SLE 15-12	N/A	N/A	1,371	1,371	4-3/4	20-1/2	13-1/2	19
SLE 25-16	N/A	N/A	1,712	1,712	4-3/4	24	14-1/2	23
SLE 25-21	\$3,151	\$3,151	1,934	1,934	6-3/4	24	15-1/2	31
SLE 25-28	3,568	3,568	2,389	2,389	6-3/4	31-1/2	15-1/2	39
SLE 35-36	4,477	4,477	2,690	2,690	6-3/4	38-1/2	15-1/2	48
SLE 45-54	6,086	6,086	3,726	3,726	6-3/4	48-1/4	16-1/2	70
SLE 35-70	N/A	6,537	N/A	4,695	6-3/4	76-1/2	20-1/2	105

Specify voltage when ordering

\$319 List adder for adjustable termination/fan delay control in lieu of a fixed controls on defrost models.

\$47 List adder for 3-prong electrical connector.

ECM = Electronically Commutated Motors

PSC = Permanent Split Capacitor

SP = Shaded Pole

Reach-In Nomenclature

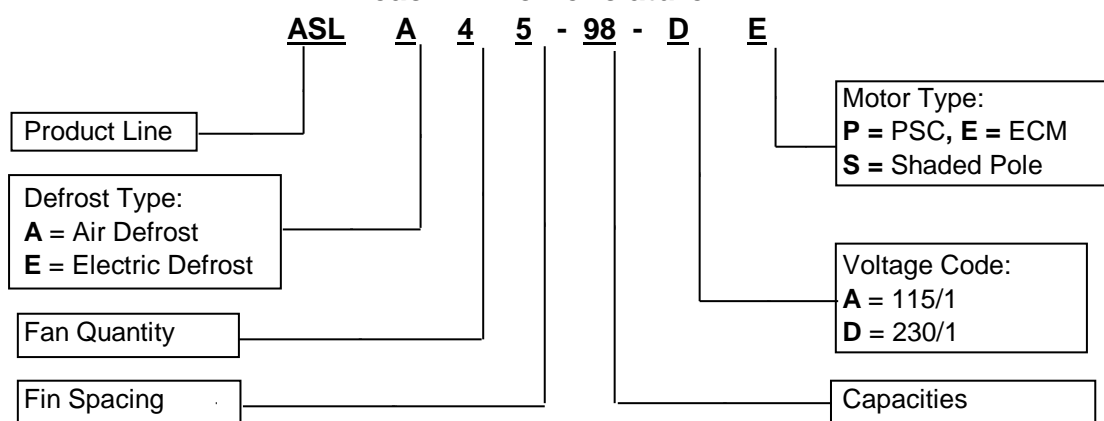

WEDGE-TEMP - CEILING MOUNTED UNIT COOLERS

Designed for reach-ins, beverage coolers and back bars from 1,200 to 5,500 BTU/HR



COOLER APPLICATION

MODEL NUMBER	UNCOATED CORE		UNCOATED CORE		RUSS PROOF CORE	RUSS PROOF CORE		RUSS PROOF CORE		DIMENSIONS			SHIP WT. (LBS)	
	Single speed ECM		SHADED POLE			MODEL NO.	Single speed ECM		SHADED POLE		HT (IN)	LT (IN)		DP (IN)
	115V	230V	115V	230V			115V	230V	115V	230V				
WE17-12	\$1,483	\$1,500	\$881	\$899	WE17-12RP	\$1,539	\$1,587	\$944	\$991	8-5/16	15-1/4	15-7/8	16	
WE17-15	1,493	1,500	901	933	WE17-15RP	1,585	1,634	983	1,032	8-5/16	15-1/4	15-7/8	19	
WE17-18	1,519	1,526	930	977	WE17-18RP	1,605	1,673	1,007	1,074	8-5/16	17-3/4	15-7/8	22	
WE17-25	1,691	1,565	1,089	1,135	WE17-25RP	1,763	1,843	1,156	1,237	8-5/16	19-7/8	16-7/8	29	
WE17-35	1,924	1,738	1,342	1,500	WE17-35RP	2,194	2,288	1,591	1,687	9-1/2	22-7/8	17-7/8	36	
WE17-45	2,266	2,081	1,688	1,797	WE17-45RP	2,649	2,825	2,050	2,226	9-5/8	26-3/4	20-1/2	57	
WE18-55	2,884	2,375	2,269	2,382	WE18-55RP	3,202	3,316	2,588	2,701	9-5/8	26-3/4	20-1/2	65	

Specify voltage when ordering - add an "A" for 115V and "D" for 230V. See Page 2 for nomenclature.

\$49 List adder for 3-prong electrical connector.

FLEX-TEMP LIMITED SPACE UNIT COOLERS

Designed for limited space, reach-ins, back bars, and beverage coolers, 600 to 3,100 BTU/HR.



COOLER APPLICATION

MODEL NUMBER	UNCOATED CORE		UNCOATED CORE		RUSS PROOF CORE	RUSS PROOF CORE		RUSS PROOF CORE		DIMENSIONS			SHIP WT. (LBS)	
	Single speed ECM		SHADED POLE			MODEL NO.	Single speed ECM		SHADED POLE		HT (IN)	LT (IN)		DP (IN)
	115V	230V	115V	230V			115V	230V	115V	230V				
FT18-6	N/A	N/A	\$662	\$685	FT18-6RP	N/A	N/A	\$692	\$708	6-3/4	12-1/2	9	9	
FT18-8	N/A	N/A	717	740	FT18-8RP	N/A	N/A	745	762	6-3/4	12-1/2	9	9	
FT28-12	N/A	N/A	816	889	FT28-12RP	N/A	N/A	905	993	7-3/4	18	9	14	
FT18-17	\$1,526	\$1,607	930	1,011	FT18-17RP	\$1,620	\$1,701	1,035	1,123	9-5/8	14	10-1/2	15	
FT18-23	2,111	2,221	1,497	1,607	FT18-23RP	2,236	2,346	1,602	1,690	11-5/8	16-3/4	13	20	
FT18-31	2,332	2,460	1,717	1,846	FT18-31RP	2,471	2,610	1,856	1,990	11-5/8	16-3/4	13	23	

Specify voltage when ordering - add an "A" for 115V and "D" for 230V. See Page 2 for nomenclature.

Unit is supplied with a three prong electrical connector.

MULLION-TEMP PANEL UNIT COOLERS

Designed for mullion, back wall, and side wall mounting from 1,300 to 2,300 BTU/HR.



COOLER APPLICATION

MODEL NUMBER	UNCOATED CORE		RUSS PROOF CORE	RUSS PROOF CORE		DIMENSIONS			SHIP WT. (LBS)
	MUF/MDF	115V		230V	MODEL NO.	115V	230V	HT (IN)	
27-13	\$1,233	\$1,297	27-13RP	\$1,254	\$1,342	17-1/8	15-5/8	5-5/8	20
27-17	1,472	1,519	27-17RP	1,504	1,592	17-1/8	15-5/8	5-5/8	22
37-23	1,760	1,883	37-23RP	1,790	1,922	17-1/8	22	5-5/8	30

Specify voltage when ordering - add an "A" for 115V and "D" for 230V. See Page 2 for nomenclature.

Unit is supplied with a three prong electrical connector.

T-TEMP UNIT COOLERS

Designed for reach-ins, beverage coolers and back bars from 800 to 1,700 BTU/HR



COOLER APPLICATION - AIR DEFROST									
MODEL NUMBER	UNCOATED CORE		RUSS PROOF CORE MODEL NO.	RUSS PROOF CORE		DIMENSIONS			SHIP WEIGHT (LBS)
	115V	230V		115V	230V	HT (IN)	LT (IN)	DP (IN)	
	TT18-8	\$618	\$667	TT18-8RP	\$703	\$752	7-1/4	13-3/4	7-1/2
TT28-13	849	906	TT28-13RP	903	969	7-1/4	19-1/4	7-1/2	15
TT28-17	946	1,011	TT28-17RP	1,009	1,084	7-1/4	19-1/4	8-1/2	16

Specify voltage when ordering - add an "A" for 115V and "D" for 230V. See Page 2 for nomenclature.

TWIN-TEMP TWO WAY CEILING UNIT COOLERS

Designed for reach-ins, beverage coolers and back bars from 900 to 12,000 BTU/HR.



COOLER APPLICATION													
MODEL NUMBER	UNCOATED CORE Single speed ECM		UNCOATED CORE SHADED POLE		RUSS PROOF CORE MODEL NO.	RUSS PROOF CORE Single speed ECM		RUSS PROOF CORE SHADED POLE		DIMENSIONS			SHIP WT. (LBS)
	115V	230V	115V	230V		115V	230V	115V	230V	HT (IN)	LT (IN)	DP (IN)	
	TW17-9	\$1,328	\$1,375	\$726	\$773	TW17-9RP	\$1,447	\$1,493	\$851	\$898	7-5/8	19	16-1/2
TW17-12	1,540	1,375	939	1,008	TW17-12RP	1,616	1,691	1,020	1,095	7-5/8	19	16-1/2	19
TW17-18	1,663	1,610	1,078	1,156	TW17-18RP	1,861	1,933	1,271	1,344	9-1/8	19	16-1/2	23
TW17-25	1,905	1,741	1,321	1,404	TW17-25RP	2,168	2,256	1,576	1,663	9-5/8	21	18-1/2	26
TW17-35	2,297	1,988	1,714	1,809	TW17-35RP	2,593	2,692	2,010	2,107	11-1/4	11	18-1/2	28
TW17-45	2,772	2,393	2,181	2,338	TW17-45RP	3,126	3,282	2,530	2,686	10	32	21-1/2	44
TW17-55	3,322	2,929	2,746	2,881	TW17-55RP	3,721	3,860	3,131	3,271	12	32	21-1/2	50
TW18-65	3,909	3,457	3,295	3,295	TW18-65RP	4,141	4,141	3,527	3,527	12	32	21-1/2	55
TW17-75	3,759	3,759	3,407	3,407	TW17-75RP	N/A	N/A	3,647	3,647	11	36-1/2	36	109
TW18-85	N/A	N/A	3,958	3,958	TW18-85RP	N/A	N/A	4,233	4,233	11	36-1/2	36	115
TW17-105	N/A	N/A	4,531	4,531	TW17-105RP	N/A	N/A	4,848	4,848	13	36-1/2	36	121
TW18-120	N/A	N/A	5,052	5,052	TW18-120RP	N/A	N/A	5,202	5,410	13	36-1/2	36	128

Specify voltage when ordering - add an "A" for 115V and "D" for 230V. See Page 2 for nomenclature.

ECM = Electronically Commutated Motors

MINI TWIN-TEMP TWO WAY UNIT COOLER ONLY 3-1/4" HIGH



COOLER APPLICATION									
MODEL NUMBER	UNCOATED CORE SHADED POLE		RUSS PROOF CORE MODEL NO.	RUSS PROOF CORE SHADED POLE		DIMENSIONS			SHIP WT. (LBS)
	115V	230V		115V	230V	HT (IN)	LT (IN)	DP (IN)	
	MTW18-8	\$724	\$724	MTW18-8RP	\$858	\$858	3-1/4	14-1/4	13
MTW28-13	954	954	MTW28-13RP	1,033	1,033	3-1/4	19-1/4	13	15
MTW28-18	1,086	1,086	MTW28-18RP	1,275	1,275	3-1/4	19-1/4	13	18
MTW28-21	1,217	1,217	MTW28-21RP	1,305	1,305	3-1/4	19-1/4	13	20
MTW38-27	1,355	1,355	MTW38-27RP	1,562	1,562	3-1/4	28-1/2	13	23

Specify voltage when ordering - add an "A" for 115V and "D" for 230V. See Page 2 for nomenclature.

WALL-TEMP PANEL UNIT COOLERS

Designed for mullion back wall and side wall mounting.
From 600 to 4,500 BTU/HR.



COOLER APPLICATION

MODEL NUMBER	UNCOATED CORE ECM	UNCOATED CORE SHADED POLE	RUSS PROOF MODEL NO.	RUSS PROOF CORE ECM	RUSS PROOF CORE SHADED POLE	DRAIN PAN*	DIMENSIONS			SHIP WT. (LBS)
	115V/230V	115V/230V		115V/230V	115V/230V		HT (IN)	WD (IN)	DP (IN)	
WA17-6	\$1,777	\$1,132	WA17-6RP	\$1,864	\$1,220	\$154	20-7/8	12	4-3/8	11
WA17-9	2,085	1,440	WA17-9RP	2,172	1,526	154	20-7/8	12	4-3/8	14
WA17-12	2,591	1,878	WA17-12RP	2,677	2,032	154	22-7/8	18	4-3/4	20
WA17-18	2,679	2,027	WA17-18RP	2,765	2,120	154	22-7/8	18	4-3/4	24
WA17-25	2,765	2,123	WA17-25RP	2,858	2,212	181	29	18	8-1/2	28
WA17-35	2,955	2,340	WA17-35RP	3,047	2,401	181	29	18	8-1/2	29
WA17-45	N/A	2,654	WA17-45RP	N/A	2,715	181	32-1/8	18	10-1/2	40

Specify voltage when ordering - add an "A" for 115V and "D" for 230V. See Page 2 for nomenclature.

\$49 List adder for 3-prong electrical connector.

*Drain Pan is optional.

ECM = Electronically Commutated Motors

NEXT-GEN ALL-TEMP LOW PROFILE UNIT COOLERS

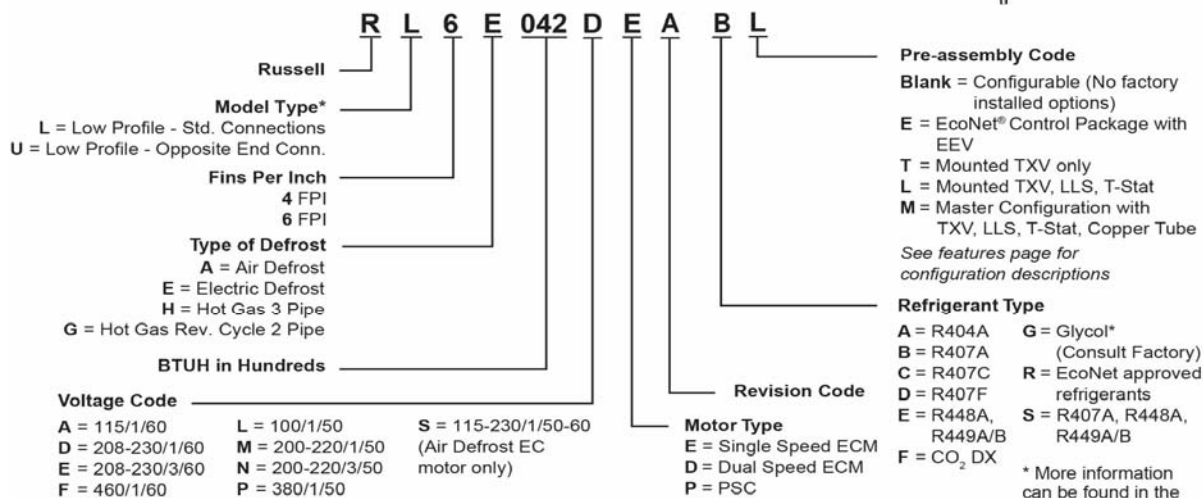

* NOTE: Refrigerant and electrical connection locations have been changed for the Next-Gen All-Temp design. Standard connections ("L") are now opposite of the legacy All-Temp models. Mirror image connections ("U" - same end as legacy All-Temp models) are available only as built-to-order base units with no installed options.

STANDARD FEATURES

- Textured aluminum construction
- All units are provided with sweat refrigerant connections
- All units suitable for use with R404A, R407A, R407C, R407F, R448A, R449A/B. Can be configured for use with CO₂ DX or Glycol
- U. L. approved black plastic fan guards and deep draw venturi provide optimal air flow
- Flush ceiling mount with slotted hangers and hinged access end panels
- Face mounted heaters and fixed defrost termination, fan delay and heater safety controls
- Single or dual voltage EC motors. Optional Dual speed available

ORDERING INFORMATION

1. Model number
2. Motor Type
3. Motor electrical (voltage/phase/frequency)
4. Heater electrical (voltage/phase/frequency)
5. Units with mounted components require the following information: refrigerant type, evaporator temperature and T.D.

NO. OF FANS	MODEL NUMBER	Electronically Commutated Motors†				Single Speed PSC Motors					Russ-Proof Coating (Other coatings are also available. Contact Applications for a special quote). See note 6 below.	Insulated Drain Pan	Heat Exchanger (Shipped loose) selected @10" T.D./R407A		Unit Cooler Approx. Ship Wt (LBS)
		Configurable Model - Single speed operation (Motor code "E". No accessories mounted)	Configurable Model - Dual speed operation (Motor code "D". No accessories mounted)	EcoNet® Control Package Pre-Assembled with factory mounted accessories - Assembly Code E (Motor code "D") See note 8 below.	Pre-Assembled with factory mounted accessories - Assembly Code L or M (Motor code "E" or "D"). See notes 1, 2 & 3 below.	Configurable Model - Single speed operation (Motor code "P". No accessories mounted)	Pre-Assembled with factory mounted accessories - Assembly Code L or M (Motor code "P"). See notes 1, 2 & 3 below.	Configurable Model - Single speed operation (Motor code "P". No accessories mounted)	Pre-Assembled with factory mounted accessories - Assembly Code L or M (Motor code "P"). See notes 1, 2 & 3 below.	Configurable Model - Single speed operation (Motor code "P". No accessories mounted)					
		115V/208-230V/1 (Voltage code "S")	115V/208-230V/1 (Voltage code "S")	115V/208-230V/1 (Voltage code "S")	115V (Voltage code "A")	115V/1 (Voltage code "A")	115V/1 (Voltage code "A")	208-230V/1 (Voltage code "D")	208-230V/1 (Voltage code "D")	460V/1 (Voltage code "F")					
1	RL6A041*	\$1,761	\$1,761	\$3,627	\$2,792	\$1,393	\$2,424	\$1,447	\$2,478	\$1,621	\$413	\$567	HX-25	\$163	41
	RL6A052*	1,809	1,809	3,675	2,840	1,445	2,476	1,467	2,498	1,648	423	567	HX-25	163	44
	RL6A066*	2,099	2,099	3,965	3,143	1,735	2,766	1,864	2,895	2,045	453	567	HX-50	192	47
2	RL6A073*	2,742	2,742	4,608	3,773	1,993	3,024	2,151	3,182	2,521	617	716	HX-50	192	52
	RL6A094*	3,106	3,106	4,972	4,137	2,357	3,388	2,394	3,425	2,767	639	716	HX-50	192	55
	RL6A117*	3,264	3,264	5,130	4,295	2,564	3,595	2,598	3,629	2,942	671	716	HX-75	264	58
	RL6A130*	3,485	3,485	5,351	4,516	2,809	3,840	2,850	3,881	3,207	702	716	HX-75	264	62
3	RL6A141*	4,216	4,216	6,082	5,247	3,131	4,162	3,176	4,207	3,711	951	869	HX-75	264	72
	RL6A161*	4,682	4,682	6,548	5,713	3,569	4,600	3,629	4,660	4,176	977	869	HX-75	264	78
	RL6A181*	5,103	5,103	6,969	6,134	4,013	5,044	4,071	5,102	4,613	1,004	869	HX-100	337	85
	RL6A195*	5,497	5,497	7,363	6,528	4,331	5,362	4,388	5,419	4,964	1,043	999	HX-100	337	115
4	RL6A235*	6,667	6,667	8,533	7,698	5,044	6,075	5,445	6,476	6,249	1,094	999	HX-150	389	124
	RL6A260*	7,265	7,265	9,131	8,296	5,290	6,321	5,699	6,730	6,377	1,145	999	HX-150	389	147
	RL6A295*	8,332	8,332	10,198	9,363	6,295	7,674	6,801	8,180	7,804	1,351	1,140	HX-150	389	218
5	RL6A330*	8,943	8,943	10,809	9,974	6,665	8,044	7,198	8,577	8,325	1,672	1,296	HX-250	538	257
	RL6A390*	10,041	10,041	11,907	11,072	7,770	9,149	8,257	9,636	9,383	1,735	1,296	HX-250	538	262

†Electronically Commutated motors are not available for 380V, 460V, or 575V. Use PSC motors for 460V volts. Use EC motors for 100-230V 50HZ operations.

††These models utilize dual voltage EC motors that are configurable for single or dual speed operation. **Dual speed EC motors are compliant with California Title 24 regulations.**

†††Dual speed motor operation employs a relay to control motor speed. LLS voltage must match the voltage applied to the motor. **Electric default: dual speed relay voltage is 230V.**

††††Specify motor speed: single (motor code E) or dual speed (motor code D) at time of order. (115 and 230 volt dual speed relays are both included with S voltage code.)

FINS PER INCH (FPI)	NO. OF FANS	MODEL NUMBER	Electronically Commutated Motors††				Single Speed PSC Motors					Contact Applications for Coil Coating prices for electric defrost models	Insulated Drain Pan	Heat Exchanger (Shipped loose) selected @10" T.D./R407A		Unit Cooler Approx. Ship Wt (LBS)
			Configurable Model - Single speed operation (Motor code "E". No accessories mounted)	Configurable Model - Dual speed operation (Motor code "D". No accessories mounted)	EcoNet® Control Package Pre-Assembled with factory mounted accessories - Assembly Code E (Motor code "D") See note 8 below.	Pre-Assembled with factory mounted accessories - Assembly Code L or M (Motor code "E" or "D"). See notes 1, 2 & 3.	Configurable Model - Single speed operation (Motor code "P". No accessories mounted)	Pre-Assembled with factory mounted accessories - Assembly Code L or M (Motor code "P"). See notes 1, 2 & 3 below.	Configurable Model - Single speed operation (Motor code "P". No accessories mounted)	Pre-Assembled with factory mounted accessories - Assembly Code L or M (Motor code "P"). See notes 1, 2 & 3 below.	Configurable Model - Single speed operation (Motor code "P". No accessories mounted)					
			208-230V/1 or 3ph† (Voltage code "D" or "E")	208-230V/1 or 3ph† (Voltage code "D" or "E")	208-230V/1 (Voltage code "D")	208-230V/1 or 3ph† (Voltage code "D" or "E")	208-230V/1 or 3ph† (Voltage code "D" or "E")	208-230V/1 or 3ph† (Voltage code "D" or "E")	460V/1 (Voltage code "F")							
6	1	RL6E035*	\$2,449	\$2,449	\$4,315	\$3,480	\$2,104	\$3,135	\$2,397	C/F	\$567	HX-25	\$163	41		
		RL6E042*	2,724	2,724	4,590	3,755	2,347	3,378	2,614	C/F	567	HX-25	163	44		
		RL6E049*	2,998	2,998	4,864	4,029	2,623	3,654	2,980	C/F	567	HX-25	163	47		
	2	RL6E066*	3,778	3,778	5,644	4,809	3,049	4,080	3,405	C/F	716	HX-50	192	52		
		RL6E077*	3,974	3,974	5,840	5,005	3,236	4,267	3,830	C/F	716	HX-50	192	55		
		RL6E090*	4,091	4,091	5,957	5,122	3,389	4,420	4,025	C/F	716	HX-50	192	58		
	3	RL6E105*	4,792	4,792	6,658	5,823	3,955	4,986	4,311	C/F	716	HX-50	192	62		
		RL6E121*	5,359	5,359	7,225	6,390	4,272	5,303	5,089	C/F	869	HX-75	264	78		
		RL6E142*	6,115	6,115	7,981	7,146	5,022	6,053	5,871	C/F	869	HX-75	264	85		
	4	RL6E162*	7,171	7,171	9,037	8,202	5,717	6,748	6,718	C/F	999	HX-75	264	124		
		RL6E182*	7,913	7,913	9,779	8,944	6,460	7,491	7,544	C/F	999	HX-100	337	147		
		RL6E200*	8,900	8,900	10,766	9,981	7,195	8,574	8,362	C/F	1,140	HX-100	337	195		
5	RL6E244*	10,441	10,441	12,307	11,820	8,245	9,624	9,614	C/F	1,296	HX-150	389	238			
	RL6E281*	11,559	11,559	13,425	12,938	9,395	10,774	10,901	C/F	1,296	HX-150	389	238			
4	1	RL4E027*	\$1,575	\$1,575	\$3,441	\$2,606	\$1,404	\$2,435	\$1,673	C/F	\$567	HX-25	\$163	40		
		RL4E032*	1,968	1,968	3,834	2,999	1,665	2,696	1,934	C/F	567	HX-25	163	42		
		RL4E038*	2,475	2,475	4,341	3,506	2,142	3,173	2,419	C/F	567	HX-25	163	46		
	2	RL4E051*	3,019	3,019	4,885	4,050	2,679	3,710	2,960	C/F	716	HX-25	163	50		
		RL4E064*	3,790	3,790	5,656	4,821	3,113	4,144	3,429	C/F	716	HX-50	192	52		
		RL4E080*	4,318	4,318	6,184	5,349	3,600	4,631	3,899	C/F	716	HX-50	192	55		
	3	RL4E094*	4,856	4,856	6,722	5,887	3,864	4,895	4,612	C/F	869	HX-50	192	79		
		RL4E110*	5,684	5,684	7,550	6,715	4,521	5,552	5,347	C/F	869	HX-50	192	84		
		RL4E125*	6,404	6,404	8,270	7,435	5,086	6,117	6,094	C/F	999	HX-75	264	124		
	4	RL4E141*	7,225	7,225	9,091	8,256	5,736	6,767	6,759	C/F	999	HX-75	264	144		
		RL4E155*	8,028	8,028	9,894	9,109	6,392	7,771	7,456	C/F	1,140	HX-75	264	191		
		RL4E195*	9,622	9,622	11,488	10,703	8,040	9,419	9,431	C/F	1,296	HX-100	337	257		
	5	RL4E230*	11,080	11,080	12,946	12,117	8,971	10,350	10,364	C/F	1,296	HX-150	389	262		

†† Electronically Commutated motors are not available for 380V, 460V, or 575V. Use PSC motors for 460V volts. Use EC motors for 100-230V 50HZ operations.

†††These models utilize dual voltage EC motors that are configurable for single or dual speed operation. **Dual speed EC motors are compliant with California Title 24 regulations.**

††††Dual speed motor operation employs a relay to control motor speed. LLS voltage must match the voltage applied to the motor. **Electric default: Dual speed relay voltage is 230V.**

†††††Specify operating voltage 230V/1 (voltage code D) or 230/3 (voltage code E) and motor speed, single (motor code E) or dual speed (motor code D) operation at time of order. (All motors are single phase.)

* Refer to nomenclature example to complete the model number.

† Reference the catalog for 3 phase heater availability.

1. Pre-Assembly code L indicates that the unit includes factory mounted txv, liquid line solenoid, mechanical room t-stat.

2. Pre-Assembled code M designates a Master unit for a 2 evaporator Master / Slave evaporator setup. A master unit includes a mounted txv, liquid line solenoid, mechanical room t-stat and copper tee. Code M models are to be matched with an identical model, suffix code T, in order to complete the Master/Slave combination. See note 3 for description of code T models.

3. For Pre-Assembled code T (mounted TXV only), select a configurable model then add \$393 for up to 3 ton requirement or \$691 for 4 to 9 ton mounted txv to price of the configurable unit.

4. See page 18 for expansion valve pricing.

5. \$332 List adder for adjustable termination/fan delay control in lieu of a fixed control.

6. Russ-Proof coating covers the coil only. Contact Application Engineering for coated housing or alternate coil coating. ElectroFin, Bronz-Glow and Heresite are available coating options.

7. Electric default: Dual speed relay voltage is 230V.

8. EcoNet® Control package includes: Sporlan EEE; suction pressure transducer; suction, entering air, coil temp thermistors; local on-board two-row LCD display and push button adjustments. Controller replaces TXV, liquid solenoid valve, room thermostat, defrost termination and fan delay, and time clock.

NEXT-GEN ALL-TEMP

HOT GAS DEFROST / REVERSE CYCLE MODELS

FINS PER INCH (FPI)	NO. OF FANS	MODEL NUMBER	Electronically Commutated Motors†				PSC Motors			Insulated Drain Pan	Heat Exchanger Field Installed		Unit Cooler Approx. Ship Wt. (LBS)	
			Configurable Model <u>Single</u> speed operation (Motor code "E". No accessories mounted)		Configurable Model - <u>Dual</u> speed motor operation (Motor code "D". No accessories mounted.)		Configurable Model - <u>Single</u> speed operation (Motor code "P". No accessories mounted)				Model	List Price		
			115V/1 (Voltage code "A")	208-230V/1 (Voltage code "D")	115V/1 (Voltage code "A")	208-230V/1 (Voltage code "D")	115V/1 (Voltage code "A")	208-230V/1 (Voltage code "D")	460V/1 (Voltage code "F")					
6	1	RL6G035*	\$2,384	\$2,439	\$2,384	\$2,439	\$2,026	\$2,080	\$2,261	\$567	HX-25	\$163	41	
		RL6G042*	2,693	2,756	2,693	2,756	2,315	2,377	2,566	567	HX-25	163	44	
		RL6G049*	3,039	3,110	3,039	3,110	2,664	2,736	2,927	567	HX-25	163	47	
	2	RL6G066*	3,648	3,882	3,648	3,882	2,918	3,152	3,513	716	HX-25	163	52	
		RL6G077*	4,039	4,271	4,039	4,271	3,303	3,535	3,896	716	HX-50	192	55	
		RL6G090*	4,280	4,568	4,280	4,568	3,564	3,853	4,216	716	HX-50	192	58	
	3	RL6G105*	5,017	5,306	5,017	5,306	4,179	4,547	4,914	716	HX-50	192	62	
		RL6G121*	5,269	5,605	5,269	5,605	4,193	4,518	5,056	869	HX-75	264	78	
		RL6G142*	6,167	6,388	6,167	6,388	5,074	5,295	5,835	869	HX-75	264	85	
	4	RL6G162*	6,848	7,280	6,848	7,280	5,393	5,825	6,553	999	HX-75	264	124	
		RL6G182*	7,670	8,238	7,670	8,238	6,218	6,786	7,510	999	HX-75	264	147	
	5	RL6G200*	8,108	8,621	8,108	8,621	6,321	6,834	7,740	1,140	HX-100	337	195	
	6	RL6G244*	9,819	10,539	9,819	10,539	7,618	8,353	9,468	1,296	HX-100	337	238	
		RL6G281*	10,935	11,799	10,935	11,799	8,772	9,628	10,726	1,296	HX-100	337	262	
	4	1	RL4G027*	\$1,642	\$1,706	\$1,642	\$1,706	\$1,404	\$1,467	\$2,001	\$567	HX-25	\$163	40
			RL4G032*	1,938	2,000	1,938	2,000	1,659	1,721	2,256	567	HX-25	163	42
			RL4G038*	2,452	2,508	2,452	2,508	2,097	2,153	2,342	567	HX-25	163	46
		2	RL4G051*	3,114	3,221	3,114	3,221	2,575	2,851	3,126	716	HX-25	163	50
RL4G064*			3,907	4,014	3,907	4,014	3,231	3,330	3,584	716	HX-25	163	52	
RL4G080*			4,392	4,519	4,392	4,519	3,673	3,800	4,071	716	HX-50	192	55	
3		RL4G094*	4,728	5,060	4,728	5,060	3,737	4,150	4,562	869	HX-50	192	79	
		RL4G110*	5,533	5,864	5,533	5,864	4,371	4,718	5,156	869	HX-50	192	84	
4		RL4G125*	6,159	6,580	6,159	6,580	4,839	5,384	5,928	999	HX-50	192	124	
		RL4G141*	6,947	7,368	6,947	7,368	5,458	5,879	6,433	999	HX-75	264	144	
5		RL4G155*	7,552	8,069	7,552	8,069	5,914	6,380	6,998	1,140	HX-75	264	191	
6		RL4G195*	9,270	9,876	9,270	9,876	7,203	7,778	8,557	1,296	HX-100	337	257	
		RL4G230*	10,685	11,421	10,685	11,421	8,576	9,290	10,085	1,296	HX-100	337	262	

- \$395 List adder for liquid txv bypass check valve, shipped loose. \$606 list price adder for liquid txv bypass check valve - factory mounted.
- Consult factory for installed suction check valve prices.
- Hot Gas reverse cycle includes a fixed defrost termination control and a fixed fan delay control, factory wired.

HOT GAS DEFROST / 3 PIPE DEFROST MODELS

FINS PER INCH (FPI)	NO. OF FANS	MODEL NUMBER	Electronically Commutated Motors†				PSC Motors			Insulated Drain Pan	Unit Cooler Approx. Ship Wt (LBS)	
			Configurable Model <u>Single</u> speed operation (Motor code "E". No accessories mounted)		Configurable Model - <u>Dual</u> speed motor operation (Motor code "D". No accessories mounted.)		Configurable Model - <u>Single</u> speed operation (Motor code "P". No accessories mounted)					
			115V/1 (Voltage code "A")	208-230V/1 (Voltage code "D")	115V/1 (Voltage code "A")	208-230V/1 (Voltage code "D")	115V/1 (Voltage code "A")	208-230V/1 (Voltage code "D")	460V/1 (Voltage code "F")			
6	1	RL6H035*	\$2,384	\$2,439	\$2,384	\$2,439	\$2,026	\$2,080	\$2,261	\$567	41	
		RL6H042*	2,693	2,756	2,693	2,756	2,315	2,377	2,566	567	44	
		RL6H049*	3,039	3,110	3,039	3,110	2,664	2,736	2,927	567	47	
	2	RL6H066*	3,648	3,882	3,648	3,882	2,918	3,152	3,513	716	52	
		RL6H077*	4,039	4,271	4,039	4,271	3,303	3,535	3,896	716	55	
		RL6H090*	4,280	4,568	4,280	4,568	3,564	3,853	4,216	716	58	
	3	RL6H105*	5,017	5,306	5,017	5,306	4,179	4,547	4,914	716	62	
		RL6H121*	5,269	5,605	5,269	5,605	4,193	4,518	5,056	869	78	
		RL6H142*	6,167	6,388	6,167	6,388	5,074	5,295	5,835	869	85	
	4	RL6H162*	6,848	7,280	6,848	7,280	5,393	5,825	6,553	999	124	
		RL6H182*	7,670	8,238	7,670	8,238	6,218	6,786	7,510	999	147	
	5	RL6H200*	8,108	8,621	8,108	8,621	6,321	6,834	7,740	1,140	195	
	6	RL6H244*	9,819	10,539	9,819	10,539	7,618	8,353	9,468	1,296	238	
		RL6H281*	10,935	11,799	10,935	11,799	8,772	9,628	10,726	1,296	262	
	4	1	RL4H027*	\$1,642	\$1,706	\$1,642	\$1,706	\$1,404	\$1,467	\$2,001	\$567	40
			RL4H032*	1,938	2,000	1,938	2,000	1,659	1,721	2,256	567	42
			RL4H038*	2,452	2,508	2,452	2,508	2,097	2,153	2,342	567	46
		2	RL4H051*	3,114	3,221	3,114	3,221	2,575	2,851	3,126	716	50
RL4H064*			3,907	4,014	3,907	4,014	3,231	3,330	3,584	716	52	
RL4H080*			4,392	4,519	4,392	4,519	3,673	3,800	4,071	716	55	
3		RL4H094*	4,728	5,060	4,728	5,060	3,737	4,150	4,562	869	79	
		RL4H110*	5,533	5,864	5,533	5,864	4,371	4,718	5,156	869	84	
4		RL4H125*	6,159	6,580	6,159	6,580	4,839	5,384	5,928	999	124	
		RL4H141*	6,947	7,368	6,947	7,368	5,458	5,879	6,433	999	144	
5		RL4H155*	7,552	8,069	7,552	8,069	5,914	6,380	6,998	1,140	191	
6		RL4H195*	9,270	9,876	9,270	9,876	7,203	7,778	8,557	1,296	257	
		RL4H230*	10,685	11,421	10,685	11,421	8,576	9,290	10,085	1,296	262	

- Hot Gas 3 Pipe Defrost models include a fixed defrost termination control and a fixed fan delay control, factory wired.
- Use EC motors for 50HZ operation.
- See page 18 for expansion valve pricing.

† Electronically Commutated motors are not available for 380V, 460V, or 575V. Use PSC motors for 460V volts. Use EC motors for 100-230V 50HZ operations.

† These models utilize single voltage EC motors that are configurable for single or dual speed operation. **Dual speed EC motors are compliant with California Title 24 regulations.**

† Dual speed motor operation employs a relay to control motor speed. LLS voltage must match the voltage applied to the motor. Electric default: dual speed relay voltage is 230V.

† Specify operating voltage: 115V (voltage code A) or 230V/1 (voltage code D) and motor speed: single (motor code E) or dual speed (motor code D) at time of order.

\$332 List adder for adjustable termination/fan delay control in lieu of a fixed controls.

Contact Application Engineering for coated housing or coil coating. ElectroFin, Bronz-Glow and Heresite are available coating options.

* Reference nomenclature example to complete the model number.

INTER-TEMP MEDIUM PROFILE UNIT COOLERS

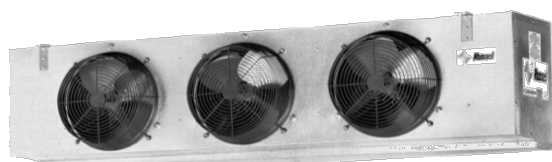

IT A 2 8 - 151 - A E

INTER-TEMP

A = Air Defrost
E = Electric Defrost
G = Hot Gas Rev. Cycle
H = Hot Gas Re-Evap

Motor Type:
P = PSC, **E** = Single Speed ECM
D = Dual Speed ECM
V = Variable Speed ECM

Voltage Code:
A = 115V/1, **D** = 230V/1
E = 208/230/3
F = 460V/1, **H** = 575V/1

BTUH in Hundreds

Fins Per Inch

Number of Fans

STANDARD FEATURES

- Use with R404A, R407A, R407C, R407F, R448A, R449A
- Textured Aluminum Construction
- U.L. approved epoxy coated fan guards
- Separate fixed defrost termination and fan delay controls
- Permanently lubricated, high efficiency, ECM or PSC motors with
- Thermal overload protection
- All components are factory wired to terminal board. Connection points are marked for easy identification.
- Partitioned fan sections.

ORDERING INFORMATION

1. Model number
2. Voltage, frequency, phase
3. Refrigerant type
4. Suction Temperature
5. Evaporator T.D.

OPTIONS

Air Straightener - Fan Guards (price per fan)	LIST	\$351
---	------	-------

AIR DEFROST MODELS

MODEL NUMBER	Electronically Commutated Motors†						PSC Motors							
	Single Speed Motors		Dual Speed Motors			Variable Speed Motors			Single Speed Motors					
	115V/1	230V/1	115V/1	230V/1	460V/1**	115V/1	230V/1	460V/1**	115V/1	230V/1	460V/1	575V/1		
8	ITA28-151	\$5,399	\$5,480	\$5,845	\$5,995	\$6,399	No longer available				\$4,732	\$4,825	\$5,012	\$5,113
	ITA28-210	6,511	6,592	6,958	7,106	7,511					5,375	5,457	5,533	5,644
	ITA38-260	8,060	8,184	8,728	8,956	9,563					6,699	6,834	7,185	7,331
F	ITA38-320	9,858	10,252	10,527	11,024	11,631					8,641	9,071	9,164	9,348
	ITA28-410	12,538	13,037	13,087	13,587	13,957					10,506	10,982	11,209	11,433
	ITA28-450	14,206	14,533	14,756	15,082	15,452					12,122	12,434	12,811	13,069
P	ITA38-540	17,499	18,099	18,323	18,923	19,478					14,583	15,159	15,472	15,781
	ITA38-690	18,327	18,712	19,152	19,536	20,091					15,897	16,277	16,821	17,158
	6	ITA26-145	5,219	5,287	5,665	5,802					6,207	4,550	4,628	4,819
ITA26-191		6,317	6,330	6,763	6,845	7,250					5,066	5,078	5,299	5,405
ITA36-240		7,784	7,955	8,453	8,727	9,334					6,375	6,558	6,921	7,061
F	ITA36-305	9,588	9,846	10,256	10,617	11,225					8,206	8,480	8,764	8,940
	ITA26-370	12,168	12,507	12,718	13,056	13,426	10,110	10,431	10,787	11,002				
	ITA36-415	13,772	13,995	14,595	14,820	15,374	11,816	12,043	12,300	12,547				
P	ITA36-490	16,918	17,274	17,742	18,099	18,653	14,057	14,401	15,024	15,325				
	ITA36-620	17,763	18,049	18,588	18,873	19,428	15,044	15,320	16,130	16,453				
	4	ITA24-126	5,014	5,099	5,459	5,614	6,018	4,386	4,483	4,644	4,737			
ITA24-169		6,079	6,186	6,525	6,701	7,105	4,908	5,019	5,170	5,273				
ITA34-224		7,488	7,645	8,157	8,418	9,024	6,113	6,282	6,908	7,046				
F	ITA34-287	9,241	9,592	9,910	10,365	10,971	7,936	8,313	8,744	8,918				
	ITA24-340	11,685	11,941	12,235	12,490	12,861	9,773	10,018	10,331	10,538				
	ITA24-395	13,202	13,852	13,751	14,401	14,771	11,442	12,079	12,670	12,925				
P	ITA34-465	16,298	16,489	17,123	17,314	17,868	13,479	13,664	14,475	14,764				
	ITA34-585	17,105	17,647	17,930	18,471	19,026	14,557	15,086	16,076	16,399				

Units with dual speed motors include a relay which controls motor speed when wired to the room T-stat. Field wiring is required unless the T-Stat is mounted on the unit.

Dual speed EC motors are compliant with California Title 24 regulations.

** These 460V/1 models use 1/3 HP motors for all units.

* Russ Proof coating on coil only.

Contact Application Engineering for coated housing or other types of coil coatings.

	MODEL NUMBER	*Russ-Proof Coil Coating	Insulated Drain Pan	HEAT. EXCHANGER @ 10° T.D./R404A		APPROX. SHIPPING WEIGHT (LBS)
				MODEL	LIST	
8 F P I	ITA28-151	\$1,269	\$1,933	HX-75	\$264	125
	ITA28-210	1,496	1,933	HX-75	264	145
	ITA38-260	1,702	2,168	HX-100	337	295
	ITA38-320	1,920	2,168	HX-150	389	330
	ITA28-410	2,219	1,933	HX-150	389	370
	ITA28-450	2,352	1,933	HX-250	538	390
6 F P I	ITA38-540	2,677	2,168	HX-250	538	430
	ITA38-690	2,784	2,168	HX-250	538	540
	ITA26-145	1,214	\$1,933	HX-75	264	120
	ITA26-191	1,430	1,933	HX-75	264	140
	ITA36-240	1,630	2,168	HX-100	337	290
	ITA36-305	1,841	2,168	HX-150	389	320
4 F P I	ITA26-370	2,122	1,933	HX-150	389	360
	ITA36-415	2,248	2,168	HX-150	389	395
	ITA36-490	2,560	2,168	HX-250	538	415
	ITA36-620	2,667	2,168	HX-250	538	520
	ITA24-126	1,132	\$1,933	HX-50	192	115
	ITA24-169	1,334	1,933	HX-75	264	130
4 F P I	ITA34-224	1,516	2,168	HX-100	337	280
	ITA34-287	1,711	2,168	HX-150	389	310
	ITA24-340	1,974	1,933	HX-150	389	345
	ITA24-395	2,094	1,933	HX-150	389	375
	ITA34-465	2,386	2,168	HX-250	538	400
	ITA34-585	2,478	2,168	HX-250	538	505

INTER-TEMP • ELECTRIC DEFROST MODELS

MODEL NUMBER	Electronically Commutated Motors†					Single Speed PSC Motors			WIDTH (INCHES)	Insulated Drain Pan	Approx. Ship Wt. (LBS)
	Single	Dual Speed		Variable Speed		230V/1	460V/1	575V/1			
	230V/1	230V/1	460V/1**	230V/1	460V/1**						
6 F P I	ITE26-130	\$5,839	\$6,353	\$6,758	No longer available	\$4,776	\$5,015	\$5,116	55	\$1,933	125
	ITE26-150	6,127	6,641	7,046		5,430	5,684	5,797	55	1,933	140
	ITE36-185	9,184	9,957	10,563		7,301	7,977	8,137	76	2,168	295
	ITE26-270	11,470	12,047	12,390		10,266	10,824	11,041	76	1,933	320
	ITE26-320	12,968	13,545	13,887		11,120	11,907	12,146	76	1,933	365
	ITE36-385	16,186	17,052	17,565		13,655	14,309	14,595	106	2,168	450
4 F P I	ITE36-460	16,813	17,679	18,192	No longer available	14,972	16,035	16,355	106	2,168	490
	ITE36-520	19,066	19,933	20,445		17,067	17,932	18,290	106	2,168	535
	ITE24-105	5,455	5,970	6,374		4,675	4,954	5,053	55	1,933	120
	ITE24-140	7,040	7,555	7,959		5,294	5,480	5,590	55	1,933	135
	ITE34-175	8,011	8,783	8,930		6,648	7,165	7,308	76	2,168	285
	ITE24-230	11,012	11,589	11,931		9,224	9,961	10,160	76	1,933	315
P I	ITE24-325	15,428	16,006	16,348	No longer available	13,060	13,849	14,125	76	1,933	350
	ITE34-390	16,313	17,180	17,692		14,310	15,273	15,580	106	2,168	425
	ITE34-510	18,573	19,440	19,952		17,395	18,696	19,072	106	2,168	530

1. Electric defrost models include fixed defrost termination and fan delay controls.
2. Standard motor wiring is single phase (208/230V/1 or 460V/1.)
3. Standard heater wiring is 3 phase.(208/230V/3, 460V/3).
4. ** These 460V/1 models use 1/3 HP motors for all units.

Specify voltage when ordering.
See page 8 for voltage codes.

† EC motors are not available for 575V applications.

NOTE: Units with dual speed motors include a relay which controls motor speed when wired to the room T-stat. Field wiring is required unless T-Stat is factory mounted.
Dual speed EC motors are compliant with California Title 24 regulations.

INTER-TEMP • HOT GAS/ 3 PIPE DEFROST MODELS

MODEL NUMBER	Electronically Commutated Motors†					Single Speed PSC motors				Insulated Drain Pan	Heat Exchanger Accumulator	Approx. Ship Wt. (LBS)		
	Single Speed		Dual Speed		Variable Speed			115V/1	230V/1				460V/1	575V/1
	115V/1	230V/1	230V/1	460V/1**	115V/1	230V/1	460V/1**							
6 F P I	ITH26-130	\$7,872	\$8,268	\$8,387	\$8,791	No longer available	\$6,375	\$6,783	\$7,077	\$7,218	\$1,933	Discontinued	125	
	ITH26-150	9,701	9,798	10,216	10,620		7,938	8,033	8,396	8,536	1,933	Discontinued	140	
	ITH36-185	11,967	12,168	12,740	13,346		10,486	10,704	11,282	11,492	2,168	Discontinued	295	
	ITH26-270	14,916	15,285	15,493	15,835		13,579	13,956	14,661	14,801	1,933	Discontinued	320	
	ITH26-320	16,654	17,075	17,232	17,573		14,519	14,932	15,893	15,973	1,933	Discontinued	365	
	ITH36-385	19,258	19,466	20,124	20,637		17,128	17,343	18,382	18,607	2,168	Discontinued	450	
4 F P I	ITH36-460	22,705	23,055	23,572	24,084	No longer available	19,909	20,253	21,492	21,763	2,168	Discontinued	490	
	ITH36-520	24,482	24,931	25,348	25,861		21,710	22,156	23,375	23,665	2,168	Discontinued	535	
	ITH24-105	7,551	7,936	8,066	8,471		6,157	6,556	7,010	7,150	1,933	Discontinued	120	
	ITH24-140	9,018	9,396	9,533	9,937		7,675	8,068	8,644	8,818	1,933	Discontinued	135	
	ITH34-175	11,523	11,729	12,295	12,443		10,064	10,285	10,947	11,166	2,168	Discontinued	285	
	ITH24-230	14,662	14,844	15,239	15,581		13,236	13,425	13,992	14,272	1,933	Discontinued	315	
P I	ITH24-325	18,486	18,812	19,063	19,405	No longer available	16,605	16,927	17,896	18,256	1,933	Discontinued	350	
	ITH34-390	21,207	21,527	22,073	22,586		18,685	19,007	20,194	20,598	2,168	Discontinued	425	
	ITH34-510	22,050	22,405	22,916	23,429		19,171	19,516	20,807	21,223	2,168	Discontinued	530	

1. Hot Gas 3 -Pipe defrost models include factory installed fixed defrost terminator and fan delay controls.
2. ** These 460V/1 models use 1/3 HP motors for all units.

Specify voltage when ordering.
See page 8 for voltage codes.

† EC motors are not available for 575V applications.

NOTE: Units with dual speed motors include a relay which controls motor speed when wired to the room T-stat. Field wiring is required unless T-Stat is factory mounted.
Dual speed EC motors are compliant with California Title 24 regulations.

INTER-TEMP • HOT GAS/ REVERSE CYCLE MODELS

MODEL NUMBER	Electronically Commutated Motors†					Single Speed PSC motors				Insulated Drain Pan	TXV Bypass Check Valve	Approx. Ship Wt. (LBS)		
	Single Speed		Dual Speed		Variable Speed			115V/1	230V/1				460V/1	575V/1
	115V/1	230V/1	230V/1	460V/1**	115V/1	230V/1	460V/1**							
6 F P I	ITG26-130	\$7,047	\$7,443	\$7,562	\$7,966	No longer available	\$5,552	5,958	\$6,257	\$6,380	\$1,933	\$395	125	
	ITG26-150	8,878	8,976	9,393	9,798		7,116	7,211	7,575	7,726	1,933	395	140	
	ITG36-185	9,801	9,955	10,573	11,180		8,320	8,490	9,159	9,342	2,168	395	295	
	ITG26-270	12,715	12,941	13,292	13,634		11,378	11,612	12,342	12,589	1,933	395	320	
	ITG26-320	14,380	14,725	14,958	15,299		12,246	12,583	13,564	13,835	1,933	811	365	
	ITG36-385	16,808	17,048	17,675	18,188		14,679	14,924	15,967	16,286	2,168	811	450	
4 F P I	ITG36-460	18,961	19,379	19,828	20,340	No longer available	16,164	16,579	17,906	18,263	2,168	811	490	
	ITG36-520	20,818	21,266	21,684	22,197		18,047	18,490	19,795	20,191	2,168	811	535	
	ITG24-105	6,731	7,112	7,246	7,650		5,337	5,731	6,189	6,313	1,933	395	120	
	ITG24-140	8,190	8,571	8,705	9,109		6,848	7,243	7,823	7,979	1,933	395	135	
	ITG34-175	9,414	9,553	10,186	10,333		7,955	8,108	8,797	8,973	2,168	395	285	
	ITG24-230	12,371	12,596	12,948	13,290		10,945	11,178	11,530	11,760	1,933	395	315	
P I	ITG24-325	16,235	16,474	16,813	17,155	No longer available	14,353	14,589	15,060	15,363	1,933	811	350	
	ITG34-390	18,438	18,760	19,304	19,817		15,917	16,241	17,067	17,409	2,168	811	425	
	ITG34-510	20,157	20,516	21,024	21,536		17,279	17,627	18,919	19,297	2,168	811	530	

1. Liquid (TXV Bypass) check valve is shipped loose for field installation. Consult factory for installed liquid check valve pricing.
2. Hot Gas Reverse Cycle models include factory installed fixed defrost terminator and fan delay controls.
3. ** These 460V/1 models use 1/3 HP motors for all units. - All Models

Specify voltage when ordering.
See page 8 for voltage codes.

NOTE: Units with dual speed motors include a relay which controls motor speed when wired to the room T-stat. Field wiring is required unless T-Stat is factory mounted.
† EC motors are not available for 575V applications.
Dual speed EC motors are compliant with California Title 24 regulations.

LOW AIR VELOCITY UNIT COOLERS

LOW VELOCITY UNIT COOLER NOMENCLATURE

R W F 050 A E 1 B 1 1 A 1 A
 I II III IV V VI VII VIII IX X XI XII XIII

I. Model Series

R – Russell

II. Unit type

W – Walk In Unit Cooler

III. Series

F – Low Air Velocity

IV. Capacity – Three Number Characters

050, 075, 100, 130, 160, 190, 220, 270, 340

V. Voltage Code

A – 115/1/60
 D – 208-230/1/60
 F – 460/1/60
 L – 100/1/50
 M – 200-220/1/50
 P – 380/1/50
 X – Other

VI. Motor/Fan Type*

E – (EC) Electronically Commutated
 P – (PSC) Permanent Split Capacitor
 X – Other

VII. Length in Fans

1, 2, 3, 4, 5, 6

VIII. Coil Density

B – 6 fpi

IX. Coil Material and Coating Options

1 – Aluminum Fins (Al)
 2 – Copper Fins (Cu)
 3 – Al + AST Coating
 4 – Al + Blygold
 5 – Al + Bronz-Glow
 6 – Al + Heresite
 8 – Baked Epoxy Coating
 X – Other

} Post Coat Materials

X. Housing Material and Coatings

1 – Aluminum, Embossed
 3 – White Painted
 6 – Stainless Steel 304
 X – Other

XI. Unit Design Configuration

A – Air Defrost
 E – Electric Defrost
 G – Hot Gas Reverse Cycle Defrost with Drain Pan Loop
 H – Hot Gas Re-Evaporative Defrost with Drain Pan Loop
 K – Hot Gas Reverse Cycle Defrost with 115V Heater
 L – Hot Gas Reverse Cycle Defrost with 208/230V Heater
 X – Other

XII. Not Currently used

XIII. Revision Code – Single Alphanumeric Character

A – Initial Release

* Shaded Pole motors are no longer available.

LOW AIR VELOCITY UNIT COOLERS

BASE MODELS

Model Number	Air Defrost 115/1/60	Fan Configuration	Approx. Net Weight (lbs)
RWF050AE1B11A1A	\$4,040	1 x 1	50
RWF075AE2B11A1A	4,634	1 x 2	75
RWF100AE2B11A1A	5,847	1 x 2	85
RWF130AE3B11A1A	6,681	1 x 3	100
RWF160AE3B11A1A	7,429	1 x 3	110
RWF190AE4B11A1A	9,265	1 x 4	120
RWF220AE4B11A1A	10,651	1 x 4	130
RWF270AE5B11A1A	11,761	1 x 5	150
RWF340AE6B11A1A	15,017	1 x 6	180

POSITION V

Voltage options

Note: "N/A" = Not available, "N/C" = No additional charge, "—" = Base model features, "C/F" = Contact Factory

Voltage Code	Adder/(Deduct) Per Fan Section	Available Based Upon Position VI Motor Options
A – 115/1/60	—	Available for motor codes E, P, S
D – 208-230/1/60	\$52	Available for motor codes E, P, S
F – 460/1/60	17	Available for motor code P only
L – 100/1/50	—	Available for motor codes E, P, S
M – 200-220/1/50	52	Available for motor codes E, P, S
P – 380/1/50	17	Available for motor code P only

POSITION VI

Motor / Fan Type options

Note: "N/A" = Not available, "N/C" = No additional charge, "—" = Base model features, "C/F" = Contact Factory

Motor / Fan Type	Adder/(Deduct) Per Fan Section	Available Based Upon Position V
E - Electronically Commutated - Single Speed	—	Available for A,D,L,M
D - Electronically Commutated - Dual Speed	\$258	Available for A,L
	258	Available for D,M
P - Permanent Split Capacitor - Price deduct	(477)	Available for A,L,D,M,F,P

POSITION VII Length in Fans - No additional charge

POSITION VIII Coil Density - 6 FPI - No additional charge

Position - IX

Coil Material and Coating options

Contact Application Engineering to obtain price quotes for special fin materials or coatings.

Position - X

Housing Material and Coating options

Contact Application Engineering to obtain price quotes for special housing materials or coatings.

LOW AIR VELOCITY UNIT COOLERS

Position - XI

Unit Design Configuration - Horizontal Air Discharge Only

Note: "N/A" = Not available, "N/C" = No additional charge, "—" = Base model features, "C/F" = Contact Factory

ELECTRIC DEFROST - Code E		
Voltage Code	Adder/(Deduct) Per Fan Section	Available Based Upon Position VI Motor Options
A - 115/1/60	N/A	N/A
D - 208-230/1/60	\$260	Available for motor codes E, P, S
F - 460/1/60	352	Available for motor code P only
L - 100/1/50	N/A	N/A
M - 200-220/1/50	260	Available for motor codes E, P, S
P - 380/1/50	352	Available for motor code P only

HOT GAS DEFROST - Reverse Cycle with Hot Gas drain pan loop - Code G		
Voltage Code	Adder/(Deduct) Per Fan Section	Available Based Upon Position VI Motor Options
A - 115/1/60	\$456	Available for motor codes E, P, S
D - 208-230/1/60	456	Available for motor codes E, P, S
F - 460/1/60	456	Available for motor code P only
L - 100/1/50	456	Available for motor codes E, P, S
M - 200-220/1/50	456	Available for motor codes E, P, S
P - 380/1/50	456	Available for motor code P only

HOT GAS DEFROST - Reverse Cycle with electric drain pan heater - Code K or L		
Voltage Code	Adder/(Deduct) Per Fan Section	Available Based Upon Position VI Motor Options
A - 115/1/60	\$298	Available for motor codes E, P, S
D - 208-230/1/60	298	Available for motor codes E, P, S
F - 460/1/60	N/A	N/A
L - 100/1/50	298	Available for motor codes E, P, S
M - 200-220/1/50	298	Available for motor codes E, P, S
P - 380/1/50	N/A	N/A

HOT GAS DEFROST - 3 pipe with Drain Pan loop - Code H		
Voltage Code	Adder/(Deduct) Per Fan Section	Available Based Upon Position VI Motor Options
A - 115/1/60	\$387	Available for motor codes E, P, S
D - 208-230/1/60	387	Available for motor codes E, P, S
F - 460/1/60	387	Available for motor code P only
L - 100/1/50	387	Available for motor codes E, P, S
M - 200-220/1/50	387	Available for motor codes E, P, S
P - 380/1/50	387	Available for motor code P only

Heat Exchanger/Accumulator (HEA) No Longer Available.

Position - XII

Insulated Drain Pan		
Fan Configuration	No Insulation	Insulated Drain Pan ¹
1 X 1	—	\$2,659
1 X 2	—	3,412
1 X 3	—	4,412
1 X 4	—	5,013
1 X 5	—	5,946
1 X 6	—	6,880

1. Insulated Drain Pan not available with stainless steel or galvanized steel pans.

Position - XIII

Revision Code: A - Initial Release

Optional Expansion Valves

Balanced Port Expansion Valve - Loose	1/4 thru 3 Tons	\$347
	4 thru 9 Tons	444
Balanced Port Expansion Valve - Mounted	1/4 thru 3 Tons	393
	4 thru 9 Tons	691

Optional Room T-Stat

Type	RANGE	LIST
Mechanical - Loose	-30 to + 100	\$297
Mechanical - Mounted @ Evap	-30 to + 100	322
Electronic - Loose	-30 to + 100	383
Electronic - Mounted @ Evap	-30 to + 100	402

Optional Liquid Line Solenoid Valve

HORSEPOWER RANGE	LOOSE	MTD
1/2 thru 3 HP	\$293	\$316
4 thru 8 HP	328	366

CEILING-TEMP DUAL DISCHARGE - LOW SILHOUETTE UNIT COOLERS

Center mount with two way air discharge.
Designed for applications that require minimal coil height.

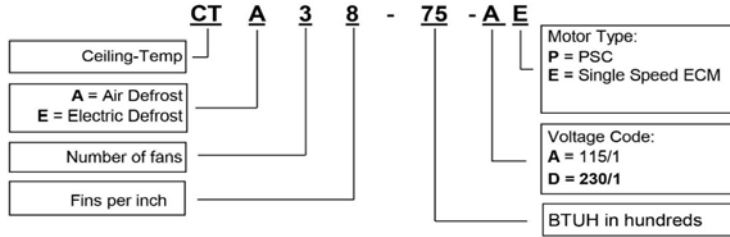

AIR DEFROST MODELS

MODEL NUMBER	Single Speed EC Motors†		PSC† Motors	Approx. Ship Weight (LBS)	INSULATED DRAIN PAN
	115V/1	230V/1	115V/1		
CTA38-75	\$3,089	\$3,401	\$2,220	95	\$4,364
CTA38-88	3,914	4,220	2,708	100	4,364
CTA38-98	4,317	4,819	3,027	105	4,364
CTA48-112	4,562	5,002	3,382	125	5,181
CTA48-130	4,721	5,838	3,748	130	5,181
CTA48-150	5,853	6,395	3,993	135	5,181
CTA58-162	6,352	6,969	4,493	150	5,820
CTA48-210	7,428	8,087	4,960	155	5,181
CTA58-230	8,233	10,414	5,567	165	5,820
CTA68-250	9,876	10,731	6,774	185	7,013
CTA36-64	3,027	3,149	2,177	90	4,364
CTA36-82	3,838	3,907	2,655	95	4,364
CTA36-93	4,233	4,462	2,968	100	4,364
CTA46-100	4,473	4,632	3,316	120	5,181
CTA46-123	5,232	5,405	3,674	125	5,181
CTA46-140	5,739	5,921	3,915	130	5,181
CTA56-157	6,229	6,453	4,404	145	5,820
CTA46-190	7,282	7,487	4,862	150	5,181
CTA56-208	8,078	8,340	5,458	160	5,820
CTA66-232	9,682	9,936	6,640	180	7,013

ELECTRIC DEFROST MODELS

MODEL NUMBER	Single Speed EC Motors†		Approx. Ship Weight (LBS)	INSULATED DRAIN PAN
	230V/1	230V/1		
CTE36-53	\$4,897		95	\$4,364
CTE36-62	5,056		100	4,364
CTE36-69	5,046		105	4,364
CTE46-77	5,809		125	5,181
CTE46-90	6,500		130	5,181
CTE46-100	6,793		135	5,181
CTE56-125	7,057		150	5,820
CTE46-140	8,141		155	5,181
CTE56-160	9,120		165	5,820
CTE66-218	11,212		185	7,013
CTE34-48	3,537		90	4,364
CTE34-58	4,915		95	4,364
CTE34-65	5,065		100	4,364
CTE44-72	5,800		120	5,181
CTE44-84	6,467		125	5,181
CTE44-95	6,482		130	5,181
CTE54-115	6,766		145	5,820
CTE44-128	7,022		150	5,181
CTE54-145	8,131		160	5,820
CTE64-173	9,133		180	7,013

1. PSC motors are not available for models with 230V/1 requirements. Use models with EC motors for 230V/1 applications.

EC motors = Electronically Commutated Motors

†EC motors are not available in 460V/1 for these models.

†Use EC motors for 50HZ operation.

All units are provided with sweat refrigerant connections. 230V/1/60 models also valid for 208V/1/60

Specify voltage when ordering. See nomenclature for available voltage and motor codes.

ULTRA-TEMP HIGH PERFORMANCE WAREHOUSE UNIT COOLERS

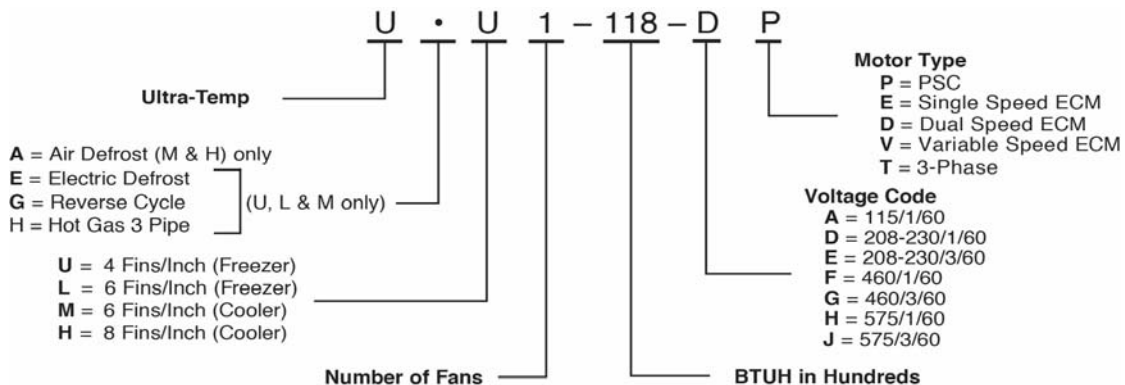

ULTRA-TEMP HIGH PERFORMANCE WAREHOUSE UNIT COOLERS

STANDARD FEATURES

- All units suitable for R404A, R507, R407A, R407C, R407F, R448A, R449A
- Textured Aluminum Construction
- U.L. approved epoxy coated wire fan guards
- All 2 through 6 fan models shipped upright for easier installation
- Adjustable defrost termination and fan delay
- PSC motors with overload protection
- All electrical components are factory wired to a terminal board, and with connection points clearly marked for easy identification
- Fully Partitioned fan sections

ORDERING INFORMATION REQUIRED

1. Model number
2. Motor electrical wiring connections (voltage, phase, frequency)
3. Heater wiring connections (voltage, phase, frequency)
4. Evaporator temperature, T.D. and refrigerant type

OPTIONS	
DESCRIPTION	LIST PRICE
Air Straightener - Fan Guards (price per fan)	\$471
Copper Finned Coil	Contact factory
Coated Coil (ElectroFin, Bronz-Glow, etc.) available for low temperature electric and hot gas model	Contact factory

AIR DEFROST - ROOM TEMPERATURE 35°F AND ABOVE

MODEL NUMBER	Electronically Commutated Motors ¹						Single Speed PSC Motors ¹				Inherent 3 Phase Motors	
	Single Speed 115V / 230V/1	Dual Speed			Variable Speed		115V/1	208-230V/1	460V/1	575V/1	208-230V/3	460V/3
		115V/1	208-230V/1	460V/1	115V/1	208-230V/1						
UAH1-182	\$5,651	\$5,927	\$5,940	\$6,111	No longer available	\$4,888	\$4,888	\$5,134	\$5,237	N/A	N/A	
UAH1-232	6,303	6,578	6,592	6,763		5,539	5,539	6,013	6,134	N/A	N/A	
UAH2-300	9,469	10,018	10,046	10,389		7,941	7,941	8,204	8,369	N/A	N/A	
UAH2-365	10,386	10,936	10,964	11,306		8,859	8,859	9,292	9,480	N/A	N/A	
UAH2-433	12,055	12,605	12,633	12,974		10,528	10,528	11,047	11,268	N/A	N/A	
UAH2-490	13,312	13,861	13,889	14,231		11,784	11,784	12,371	12,619	N/A	N/A	
UAH3-530	13,707	14,532	14,574	15,086		11,417	11,417	11,922	12,162	N/A	N/A	
UAH3-648	15,240	16,065	16,106	16,619		12,949	12,949	13,346	13,614	N/A	N/A	
UAH3-736	18,241	19,065	19,107	19,620		15,949	15,949	16,628	16,961	N/A	N/A	
UAH4-866	19,035	20,134	20,191	20,874		15,981	15,981	16,784	17,120	N/A	N/A	
UAH4-980	20,663	21,761	21,817	22,501		17,608	17,608	18,651	19,025	N/A	N/A	
UAH4-1100	22,509	23,608	23,664	24,347		19,454	19,454	20,433	20,842	N/A	N/A	
UAH4-1452†	31,199	N/A	32,657	33,190		N/A	27,531	28,904	29,483	Contact Factory		
UAH4-1821†	38,423	N/A	39,881	40,413		N/A	34,755	36,497	37,227			
UAH5-2275†	41,070	N/A	42,893	43,557		N/A	36,484	38,794	39,866			
UAH6-2730†	48,933	N/A	51,120	51,919		N/A	43,430	45,187	46,092			
UAM1-164	5,492	5,767	5,780	5,952	No longer available	4,728	4,728	4,962	5,063	N/A	N/A	
UAM1-209	6,235	6,509	6,524	6,772		5,471	5,471	5,738	5,852	N/A	N/A	
UAM2-270	9,467	10,016	10,044	10,386		7,939	7,939	8,339	8,506	N/A	N/A	
UAM2-329	10,345	10,894	10,922	11,264		8,818	8,818	9,259	9,445	N/A	N/A	
UAM2-390	11,730	12,280	12,308	12,650		10,203	10,203	10,708	10,922	N/A	N/A	
UAM2-441	13,059	13,609	13,638	13,979		11,533	11,533	12,101	12,344	N/A	N/A	
UAM3-583	13,979	14,803	14,845	15,358		11,689	11,689	11,766	12,002	N/A	N/A	
UAM3-662	15,220	16,045	16,087	16,599		12,930	12,930	13,390	13,659	N/A	N/A	
UAM4-780	18,034	19,133	19,189	19,872		14,979	14,979	15,419	15,728	N/A	N/A	
UAM4-882	19,220	20,320	20,376	21,059		16,166	16,166	16,633	16,966	N/A	N/A	
UAM4-1100†	23,058	N/A	24,516	25,048		N/A	19,390	20,910	21,328	N/A	N/A	
UAM4-1320†	31,076	N/A	32,534	33,066		N/A	27,407	28,525	29,097	Contact Factory		
UAM4-1656†	33,026	N/A	34,484	35,016		N/A	29,357	30,223	30,830			
UAM5-2065†	37,909	N/A	39,732	40,895		N/A	33,324	35,566	36,277			
UAM6-2480†	46,705	N/A	48,527	49,690		N/A	41,202	42,248	43,093			

MODEL NUMBER	HT.EXCH @10 T.D./R404A		Insulated Drain Pan	SHIP WT. (LBS)
	MODEL	LIST		
UAH1-182	HX-150	\$337	\$2,521	210
UAH1-232	HX-150	337	2,521	230
UAH2-300	HX-250	538	2,824	370
UAH2-365	HX-250	538	2,824	410
UAH2-433	HX-250	538	2,824	435
UAH2-490	HX-250	538	2,824	458
UAH3-530	HX-250	538	3,126	550
UAH3-648	HX-350	552	3,126	600
UAH3-736	HX-350	552	3,126	635
UAH4-866	HX-350	552	3,383	690
UAH4-980	HX-500	875	3,383	746
UAH4-1100	(2) HX-350	1,104	3,383	785
UAH4-1452†	(2) HX-350	1,104	3,383	905
UAH4-1821†	(2) HX-500	1,750	3,383	930
UAH5-2275†	(2) HX-500	1,750	3,691	1,160
UAH6-2730†	(2) HX-500	1,750	3,997	1,395

MODEL NUMBER	HT.EXCH @10 T.D./R404A		Insulated Drain Pan	SHIP WT. (LBS)
	MODEL	LIST		
UAM1-164	HX-150	\$337	\$2,521	200
UAM1-209	HX-150	337	2,521	220
UAM2-270	HX-250	538	2,824	360
UAM2-329	HX-250	538	2,824	400
UAM2-390	HX-250	538	2,824	425
UAM2-441	HX-250	538	2,824	446
UAM3-583	HX-350	552	3,126	585
UAM3-662	HX-350	552	3,126	620
UAM4-780	HX-350	552	3,383	675
UAM4-882	HX-350	552	3,383	726
UAM4-1100†	(2) HX-350	1,104	3,383	830
UAM4-1320†	(2) HX-350	1,104	3,383	885
UAM4-1656†	(2) HX-500	1,750	3,383	910
UAM5-2065†	(2) HX-500	1,750	3,691	1,135
UAM6-2480†	(2) HX-500	1,750	3,997	1,365

1. Motors are single phase. 3 thru 6 fan models are delta wired for 3 phase supply voltage unless otherwise specified.

2. Single speed Electronically Commutated motors are not available in 460V or 575V.

Dual speed EC motors are compliant with California Title 24 regulations.

† 115V motors are not available for these models.

230V motors are suitable for 208V operation.

Specify voltage and motor type when ordering. See page 13 for codes and nomenclature.

**ULTRA-TEMP
HIGH PERFORMANCE WAREHOUSE UNIT COOLERS**

ELECTRIC DEFROST - LOW TEMPERATURE -BELOW +20°F ROOM														
MODEL NUMBER	Electronically Commutated Motors					Single Speed PSC Motors			3 Phase Motors		Heat Exchanger @10° TD		Insulated Drain Pan	Approx. Ship Wt. (LBS)
	Single Speed	Dual Speed		Variable Speed		230V/1	460V/1	575V/1	208-230V/3	460V/3	MODEL	LIST		
	208-230V/1 ††	208-230V/1	460V/1	208-230V/1	460V/1									
UEL1-125	N/A	N/A	N/A	No longer available	Contact Factory	\$5,283	\$5,751	\$5,867	N/A	N/A	HX-150	\$337	\$2,521	180
UEL1-152	N/A	N/A	N/A			5,861	6,492	6,622	N/A	N/A	HX-150	337	2,521	200
UEL1-193	N/A	N/A	N/A			7,235	7,708	7,862	N/A	N/A	HX-150	337	2,521	220
UEL2-240	N/A	N/A	N/A			9,976	10,477	10,687	N/A	N/A	HX-250	538	2,824	360
UEL2-304	N/A	N/A	N/A			10,895	11,440	11,669	N/A	N/A	HX-250	538	2,824	400
UEL2-361	\$14,029	\$14,758	\$15,024			12,194	12,800	13,056	Contact Factory	Contact Factory	HX-350	552	2,824	425
UEL2-408	15,037	15,766	16,032			13,203	13,988	13,655			HX-350	552	2,824	446
UEL3-445	16,421	17,514	17,913			13,669	13,823	14,099			HX-500	875	3,126	525
UEL3-540	18,302	19,396	19,795			15,551	16,332	16,660			HX-500	875	3,126	585
UEL3-613	19,684	20,778	21,178			16,933	17,746	18,101			HX-500	875	3,126	620
UEL3-660	21,631	22,725	23,124			18,880	19,737	20,133			HX-500	875	3,126	645
UEL4-722	23,030	24,488	25,020			19,361	21,208	21,631			HX-500	875	3,383	675
UEL4-817	28,434	29,892	30,424			24,764	26,004	26,525			HX-500	875	3,383	726
UEL4-950*	31,144	32,602	33,134			27,476	28,035	28,597			HX-500	875	3,383	850
UEL4-1100*	31,510	32,968	33,499			27,841	28,886	29,464			(2) HX-500	1,750	3,383	885
UEL4-1260*	36,338	37,796	38,328	32,670	33,384	34,053	(2) HX-500	1,750			3,383	900		
UEL4-1380*	39,298	40,757	41,288	35,629	36,545	37,277	(2) HX-500	1,750			3,383	910		
UEL5-1575*	49,035	50,857	51,523	44,449	47,832	48,790	(2) HX-500	1,750			3,691	1,125		
UEL5-1725*	52,414	54,236	54,902	47,828	49,358	52,509	(2) HX-500	1,750			3,691	1,175		
UEL6-1890*	57,378	59,565	60,364	52,264	55,772	56,888	(2) HX-500	1,750			3,997	1,345		
UEL6-2070*	64,265	66,452	67,251	58,762	59,979	61,179	(2) HX-500	1,750	3,997	1,365				
UEU1-118	N/A	N/A	N/A	No longer available	Contact Factory	6,042	6,343	N/A	N/A	N/A	HX-150	337	2,521	180
UEU2-236	N/A	N/A	N/A			10,550	11,073	N/A	N/A	N/A	HX-250	538	2,824	370
UEU2-355	15,339	16,432	16,831			13,504	13,693	13,967	Contact Factory	Contact Factory	HX-350	552	2,824	440
UEU3-474	18,487	19,945	20,478			15,735	15,843	16,161			HX-350	552	3,126	570
UEU4-711	23,794	25,252	25,785			20,126	20,387	20,797			HX-500	875	3,383	665
UEU4-851*	30,682	32,140	32,673			27,013	27,228	27,775			(2) HX-500	1,750	3,383	875
UEU4-1080*	35,240	36,698	37,230			31,571	32,590	33,243			(2) HX-500	1,750	3,383	900
UEU5-1350*	48,521	50,343	51,009			43,935	44,624	45,518			(2) HX-500	1,750	3,691	1,125
UEU6-1620*	60,906	63,093	63,890			55,402	59,815	61,012			(2) HX-500	1,750	3,997	1,350

ELECTRIC DEFROST - MEDIUM TEMPERATURE -ABOVE + 30°F ROOM														
MODEL NUMBER	Electronically Commutated Motors					Single Speed PSC Motors			3 Phase Motors		Heat Exchanger @10° TD		Insulated Drain Pan	Approx. Ship Wt. (LBS)
	Single Speed	Dual Speed		Variable Speed		230V/1	460V/1	575V/1	208-230V/3	460V/3	MODEL	LIST		
	208-230V/1 ††	208-230V/1	460V/1	208-230V/1	460V/1									
UEM1-164	\$6,837	\$7,126	\$7,297	No longer available	Contact Factory	\$6,074	\$6,384	\$6,511	N/A	N/A	HX-150	\$337	\$2,521	200
UEM1-209	7,921	8,210	8,380			7,157	7,632	7,783	N/A	N/A	HX-150	337	2,521	220
UEM2-270	10,771	11,348	11,691			9,244	9,852	10,050	N/A	N/A	HX-250	538	2,824	360
UEM2-329	12,164	12,742	13,083			10,637	11,337	11,564	N/A	N/A	HX-250	538	2,824	400
UEM2-390	14,317	14,894	15,236			12,789	13,290	13,557	N/A	N/A	HX-250	538	2,824	425
UEM2-441	15,646	16,223	16,565			14,119	14,825	15,123	N/A	N/A	HX-250	538	2,824	446
UEM3-583	18,623	19,490	20,002			16,332	17,419	17,767	Contact Factory	Contact Factory	HX-350	552	3,126	585
UEM3-662	20,060	20,926	21,439			17,769	18,484	18,854			HX-350	552	3,126	620
UEM4-780	24,092	25,247	26,082			21,037	21,266	21,692			HX-350	552	3,383	675
UEM4-882	27,969	29,124	29,958			24,914	25,837	26,354			HX-350	552	3,383	726
UEM4-1100	31,778	33,236	33,768			28,109	29,514	30,105			(2) HX-350	1,104	3,383	830
UEM4-1320	38,640	40,098	40,631			34,972	37,273	38,018			(2) HX-350	1,104	3,383	885
UEM4-1656	50,182	51,640	52,173			46,514	48,104	49,067			(2) HX-500	1,750	3,383	910
UEM5-2065	61,955	63,777	64,443			57,368	58,789	59,964			(2) HX-500	1,750	3,691	1,140
UEM6-2480	71,917	74,104	74,903			63,859	65,253	66,558			(2) HX-500	1,750	3,997	1,365

- Standard motors are single phase. Three thru six fan models are delta wired for 3 phase supply unless otherwise specified.
 - Single speed Electronically Commutated motors are not available in 460V or 575V. 230V motors are suitable for 208V operation.
- Dual speed EC motors are compliant with California Title 24 regulations.
- * - 2 liq. and suction connections per evaporator - 2 TXV's needed when ordering with unit. EC motors are not available for models with 1625 RPM motors.
- †† ECM motors only available in single phase. Can be delta wired for 3 phase operation.

- Ordering Information Required:**
- Model Number.
 - Motor type
 - Electrical connections (voltage/phase/frequency). See page 13 for codes and nomenclature.
 - Evaporator temperature, T.D. and refrigerant type

**ULTRA-TEMP
HOT GAS 3 PIPE DEFROST**

LOW TEMPERATURE - BELOW + 20°F ROOM

MODEL NUMBER	Electronically Commutated Motors						Single Speed PSC Motors			3 Phase Motors		Ht. Exch./Re-Evap No Longer Available	Insulated Drain Pan	Approx. Ship Wt. (LBS)
	Single Speed	Dual Speed		Variable Speed		230V/1	460V/1	575V/1	208-230V/3	460V/3				
	230V ††	230V/1	460V/1	230V/1	460V/1									
UHL1-125	N/A	N/A	N/A	No longer available	\$6,506	\$6,831	N/A	N/A	N/A	Discontinued	\$2,521	180		
UHL1-152	N/A	N/A	N/A		7,044	7,395	N/A	N/A	N/A	Discontinued	2,521	200		
UHL1-193	N/A	N/A	N/A		8,242	8,647	N/A	N/A	N/A	Discontinued	2,521	220		
UHL2-240	N/A	N/A	N/A		11,511	12,087	N/A	N/A	N/A	Discontinued	2,824	370		
UHL2-304	N/A	N/A	N/A		12,419	13,044	N/A	N/A	N/A	Discontinued	2,824	400		
UHL2-361	\$16,774	\$17,503	\$17,769		14,940	15,685	\$15,999	N/A	N/A	Discontinued	2,824	425		
UHL2-408	18,417	19,146	19,412		16,583	17,410	17,758	N/A	N/A	Discontinued	2,824	446		
UHL3-445	20,274	21,368	21,766		17,522	18,406	18,775	Contact Factory	N/A	Discontinued	3,126	525		
UHL3-540	21,993	23,086	23,485		19,241	20,207	20,612			Discontinued	3,126	585		
UHL3-613	22,778	23,871	24,270		20,164	21,170	21,595			Discontinued	3,126	620		
UHL3-660	24,491	25,585	25,983		21,877	22,976	23,434			Discontinued	3,126	645		
UHL4-722	28,383	29,841	30,373		24,567	25,796	26,313			Discontinued	3,383	675		
UHL4-817	33,075	34,533	35,065		29,259	30,717	31,332			Discontinued	3,383	726		
UHL4-950*	37,602	39,060	39,593		34,007	35,709	36,423			Discontinued	3,383	850		
UHL4-1100*	42,594	44,052	44,584		38,925	40,872	41,689			Discontinued	3,383	885		
UHL4-1260*	48,591	50,049	50,581		44,923	47,163	48,107			Discontinued	3,383	900		
UHL4-1380*	53,508	54,966	55,499	49,840	52,332	53,379	Discontinued			3,383	910			
UHU1-118	N/A	N/A	N/A	No longer available	6,954	7,298	N/A	N/A	N/A	Discontinued	2,521	180		
UHU2-236	N/A	N/A	N/A		12,384	13,000	N/A	N/A	N/A	Discontinued	2,824	370		
UHU2-355	18,917	19,646	19,912		17,082	17,934	18,293	N/A	N/A	Discontinued	2,824	440		
UHU3-474	24,664	25,757	26,156		21,912	22,608	23,060	Contact Factory	N/A	Discontinued	3,126	570		
UHU4-711	34,708	35,801	36,200		31,039	32,586	33,238			Discontinued	3,383	665		
UHU4-851*	39,895	40,988	41,388		36,226	38,039	38,800			Discontinued	3,383	875		
UHU4-1080*	51,245	52,338	52,737		47,576	49,957	50,957			Discontinued	3,383	900		

MEDIUM TEMPERATURE - ABOVE + 28°F ROOM

MODEL NUMBER	Electronically Commutated Motors						Single Speed PSC Motors			3 Phase Motors		Ht. Exch./Re-Evap No Longer Available	Insulated Drain Pan	Approx. Ship Wt. (LBS)
	Single Speed	Dual Speed		Variable Speed		115V/230V ††	460V/1	575V/1	208-230V/3	460V/3				
	115/230V ††	230V/1	460V/1	230V/1	460V/1									
UHM1-164	\$7,524	\$7,812	\$7,984	No longer available	\$6,760	\$7,097	\$7,239	N/A	N/A	Discontinued	\$2,521	200		
UHM1-209	8,370	8,659	8,830		7,637	8,015	8,175	N/A	N/A	Discontinued	2,521	220		
UHM2-270	11,978	12,556	12,897		10,481	11,003	11,224	N/A	N/A	Discontinued	2,824	360		
UHM2-329	13,036	13,614	13,956		11,548	12,132	12,374	N/A	N/A	Discontinued	2,824	400		
UHM2-390	15,262	15,839	16,181		13,796	14,479	14,768	N/A	N/A	Discontinued	2,824	425		
UHM2-441	18,596	19,174	19,516		16,977	17,824	18,180	N/A	N/A	Discontinued	2,824	446		
UHM3-583	21,705	22,571	23,084		19,299	20,265	20,670	Contact Factory	N/A	Discontinued	3,126	585		
UHM3-662	22,655	23,522	24,034		20,365	21,383	21,812			Discontinued	3,126	620		
UHM4-780	25,531	26,685	27,370		22,476	23,596	24,069			Discontinued	3,383	675		
UHM4-882	30,036	31,192	31,875		26,982	28,331	28,897			Discontinued	3,383	726		
UHM4-1100†	35,524	36,982	37,515		31,856	33,460	34,130			Discontinued	3,383	830		
UHM4-1320†	41,451	42,909	43,442		37,783	39,666	40,460			Discontinued	3,383	885		
UHM4-1656†	52,363	53,821	54,354		48,694	51,127	52,151			Discontinued	3,383	910		

† - Models not available with 115V motors.

230V motors are suitable for 208V operation.

* - Two liquid and suction connections per evaporator - 2 TXV's required.

EC motors not available for models with 1625 RPM motors.

1. Standard motors are single phase. 3 thru 6 fan models are delta wired for 3 phase supply.

2. Single speed Electronically Commutated motors are not available in 460V or 575V.

3. Models with 24" fans not available with 115V motors.

Dual speed EC motors are compliant with California Title 24 regulations.

†† ECM motors only available in single phase. Can be delta wired for 3 phase operation.

Ordering Information Required:

1. Model Number
2. Electrical connections. See page 13 for voltage codes and an example of nomenclature layout.
3. Evaporator temperature, T.D. and refrigerant type

**ULTRA-TEMP
HOT GAS - REVERSE CYCLE**

LOW TEMPERATURE - BELOW + 20°F ROOM

MODEL NUMBER	Electronically Commutated Motors					Single Speed PSC Motors			3 Phase Motors		Insulated Drain Pan	Heat Exchanger @10° TD		Approx. Ship Wt. (LBS)
	Single Speed	Dual Speed		Variable Speed		230V/1	460V/1	575V/1	208-230V/3	460V/3		MODEL	LIST	
	230V ††	230V/1	460V/1	230V/1	460V/1									
UGL1-125	N/A	N/A	N/A	No longer available	\$5,702	\$5,988	N/A	N/A	N/A	\$2,521	HX-150	\$337	180	
UGL1-152	N/A	N/A	N/A		6,246	6,555	N/A	N/A	N/A	2,521	HX-150	337	200	
UGL1-193	N/A	N/A	N/A		7,306	7,677	N/A	N/A	N/A	2,521	HX-150	337	220	
UGL2-240	N/A	N/A	N/A		10,093	10,596	N/A	N/A	N/A	2,824	HX-250	538	370	
UGL2-304	N/A	N/A	N/A		11,007	11,558	N/A	N/A	N/A	2,824	HX-250	538	400	
UGL2-361	\$14,352	\$14,717	\$14,850		12,517	13,022	\$13,283	Contact Factory	N/A	N/A	2,824	HX-350	552	425
UGL2-408	15,136	15,501	15,634		13,302	13,835	14,112				2,824	HX-350	552	446
UGL3-445	19,400	19,764	19,897		16,208	16,857	17,194				3,126	HX-500	875	525
UGL3-540	21,112	21,477	21,610		18,002	18,722	19,096				3,126	HX-500	875	585
UGL3-613	21,598	21,963	22,096		18,598	19,345	19,732				3,126	HX-500	875	620
UGL3-660	22,965	23,329	23,462		19,884	20,677	21,090				3,126	HX-500	875	645
UGL4-722	25,833	26,197	26,330		21,979	22,751	23,207				3,383	HX-500	875	675
UGL4-817	30,022	30,386	30,519		26,170	26,696	27,228				3,383	HX-500	875	726
UGL4-950*	32,900	33,265	33,399		29,158	30,030	30,630				3,383	HX-500	875	850
UGL4-1100*	34,273	34,637	34,770		30,495	31,008	31,628				3,383	(2) HX-500	1,750	885
UGL4-1260*	38,288	38,653	38,786		34,546	35,587	36,298				3,383	(2) HX-500	1,750	900
UGL4-1380*	42,100	42,465	42,598	38,358	39,986	40,787	3,383				(2) HX-500	1,750	910	
UGL5-1575*	46,656	47,020	47,154	42,070	47,432	48,382	3,691				(2) HX-500	1,750	1,125	
UGL5-1725*	50,392	50,757	50,889	45,806	48,369	49,338	3,691				(2) HX-500	1,750	1,175	
UGL6-1890*	57,219	57,583	57,716	51,936	53,752	54,828	3,997				(2) HX-500	1,750	1,250	
UGL6-2070*	61,936	62,300	62,433	56,984	61,691	62,925	3,997				(2) HX-500	1,750	1,300	
UGU1-118	N/A	N/A	N/A	No longer available	5,969	6,270	N/A	N/A	N/A	\$2,521	HX-150	337	180	
UGU2-236	N/A	N/A	N/A		10,641	11,177	N/A	N/A	N/A	2,824	HX-250	538	370	
UGU2-355	17,262	17,991	18,257		15,003	15,554	17,262	Contact Factory	N/A	N/A	2,824	HX-350	552	440
UGU3-474	20,399	21,492	21,891		18,073	18,992	20,399				3,126	HX-350	552	570
UGU4-711	27,617	29,075	29,607		20,794	21,127	27,617				3,383	HX-500	875	665
UGU4-851*	33,383	34,841	35,374		26,999	27,927	33,383				3,383	(2) HX-500	1,750	875
UGU4-1080*	36,639	38,097	38,630		31,323	33,471	36,639				3,383	(2) HX-500	1,750	900
UGU5-1350*	49,593	51,416	52,081		44,215	46,874	49,593				3,691	(2) HX-500	1,750	1,150
UGU6-1620*	65,376	65,376	66,869		61,415	66,488	65,376				3,997	(2) HX-500	1,750	1,275

MEDIUM TEMPERATURE - ABOVE + 30°F ROOM

MODEL NUMBER	Electronically Commutated Motors					Single Speed PSC Motors			3 Phase Motors		Insulated Drain Pan	Ht.Exch @10° TD		Approx. Ship Wt. (LBS)
	Single Speed	Dual Speed		Variable Speed		230V/1	460V/1	575V/1	208-230V/3	460V/3		MODEL	LIST	
	115V / 230V/1	230V/1	460V/1	230V/1	460V/1									
UGM1-164	\$7,122	\$7,411	\$7,582	No longer available	\$6,313	\$6,633	\$6,765	N/A	N/A	\$2,521	HX-150	\$337	200	
UGM1-209	7,946	8,235	8,405		7,166	7,519	7,669	N/A	N/A	2,521	HX-150	337	220	
UGM2-270	11,165	11,744	12,085		9,609	10,094	10,296	N/A	N/A	2,824	HX-250	538	360	
UGM2-329	12,200	12,777	13,120		10,641	11,172	11,395	N/A	N/A	2,824	HX-250	538	400	
UGM2-390	14,425	15,002	15,344		12,867	13,513	13,783	N/A	N/A	2,824	HX-250	538	425	
UGM2-441	18,466	19,044	19,386		16,665	17,500	17,851	N/A	N/A	2,824	HX-250	538	446	
UGM3-583	21,569	22,435	22,948		18,888	19,827	20,222	Contact Factory	N/A	N/A	3,126	HX-350	552	585
UGM3-662	22,620	23,486	23,999		19,940	20,938	21,356				3,126	HX-350	552	620
UGM4-780	23,748	24,903	25,587		20,327	23,265	23,730				3,383	HX-350	552	675
UGM4-882	28,190	29,346	30,029		24,677	28,708	29,282				3,383	HX-350	552	726
UGM4-1100†	34,336	35,794	36,326		30,374	31,895	32,532				3,383	(2) HX-350	1,104	830
UGM4-1320†	38,864	40,322	40,853		35,012	36,760	37,495				3,383	(2) HX-350	1,104	885
UGM4-1656†	46,357	47,815	48,346		41,679	46,090	47,011				3,383	(2) HX-500	1,750	910
UGM5-2065†	51,397	53,220	53,884		46,719	57,606	58,757				3,691	(2) HX-500	1,750	1,130
UGM6-2480†	62,401	64,588	65,387		57,480	66,412	67,740				3,997	(2) HX-500	1,750	1,250

† - These models not available with 115V motors.

* Two liquid and suction connections per evaporator - 2 TXV's required.

1. Standard motors are single phase. Three thru six fan models are delta wired for 3 phase supply voltage.

2. List adder - Liquid TEV bypass check valve, shipped loose. \$395 (Through 270), \$1086 (Through 583), \$1721 (Through 2840).

3. Single speed Electronically Commutated motors are not available in 460V or 575V.

4. Models with 24" fans not available with 115V motors. 230V motors are suitable for 208V operation.

Dual speed EC motors are compliant with California Title 24 regulations.

†† ECM motors only available in single phase. Can be delta wired for 3 phase operation.

EC motors not available for models with 1625 RPM motors.

Ordering Information Required:

1. Model Number.

2. Electrical connections (voltage/phase/frequency). See page 13 for codes and nomenclature layout.

3. Evaporator temperature, T.D. and refrigerant type.

SYSTEM PRICING EXAMPLES

Example 1:

5 HP, R404A +35°F cooler matched with 2 unit coolers,
95°F summer ambient, 10°F winter ambient.

QTY.		LIST PRICE
1	RFDS05M4SEA Outdoor Condensing Unit 230/3/60 53,000 BTUH @ 25° S.T. and 95° ambient	\$22,430
2	RL6A235-AE Unit Coolers 115V/1/60	13,335
Field installed components		
2	Thermostatic expansion valves	684
1	Liquid line solenoid valve (loose)	328
1	Room thermostat (loose)	297
Optional accessories		
1	Air defrost timer installed	<u>577</u>
TOTAL LIST PRICE		\$37,651
1	Additional 4 year Compressor Protection Plans	NET PRICE \$472

Example 2:

10HP, R404A, -10°F Freezer, matched with 2 unit coolers
95°F Summer ambient, 35°F winter ambient

QTY.		LIST PRICE
1	RFDS10L4SEA Outdoor Condensing 230/3/60 50,300 BTUH @ -20° S.T. and 95° ambient	\$39,022
1	DMB35 Electric defrost provisions, factory installed	2,217
2	UEL2-304 unit coolers, 230/1/60 motors, 230/3/60 defrost 25,150 BTUH each @ 9 T.D.	21,790
Field installed components		
2	Thermostatic expansion valves (loose)	1,148
1	Liquid line solenoid valve (loose)	474
1	Room thermostat (loose)	297
Optional accessories		
1	Suction Accumulator (mounted)	1,201
1	Oil separator (mounted)	1,481
2	RXH - 350 Heat exchangers (field installed)	<u>1,104</u>
TOTAL LIST PRICE		\$68,734
1	Additional 4 year Compressor Protection Plans	NET PRICE \$854

OPTIONAL SYSTEM COMPONENTS

HEAT EXCHANGERS - Shipped Loose

MODEL NUMBER	PART NUMBER	LIST PRICE	CONNECTIONS (inches)		APPROXIMATE LENGTH (inches)
			LIQUID	SUCTION	
HX-25	105065001	\$163	1/4	1/2	12
HX-50	105065003	192	3/8	5/8	13
HX-75	105065004	264	3/8	7/8	14
HX-100	105065005	337	3/8	1-1/8	14
HX-150	105065006	389	1/2	1-1/8	14
HX-250	105065007	538	5/8	1-3/8	14
HX-350	105065008	552	5/8	1-5/8	16
HX-500	105065009	875	7/8	2-1/8	17
LHX-15	105065010	2,400	7/8	2-1/8	30
LHX-20	105065011	2,568	1-1/8	2-1/8	30
LHX-25	105065012	2,750	1-1/8	2-5/8	38

EXPANSION VALVES

BALANCED PORT TXV'S		LIST
1/4 - 3 Tons	Loose	\$347
	Installed	393
4 - 9 Tons	Loose	444
	Installed	691
10 - 30 Tons	Loose	771
	Installed	1,141
Electronic Expansion Valves		List
1 to 15 Tons	Loose	\$1,061
	Installed	1,402
16 to 25 Tons	Loose	1,524
	Installed	1,865

1. EEV prices include cable.
2. EEV prices DO NOT include controller.

ECONET® ENABLED UNIT COOLERS - SEE PAGE 6

KE2 EVAP- OEM EVAPORATOR DEFROST CONTROL *

DESCRIPTION	PART NUMBER	EACH
Factory Installed - For NEXT-GEN ALL-TEMP Low Profile 115V or 230V/1 (Air or Electric Defrost Models)	0829632	\$3,944

*1Ø units only. **Internally mounted control board**, external display, mounted sensors and EEV.

SURVEILLANT EVAPORATOR DEFROST CONTROL *

DESCRIPTION	PART NUMBER	LIST EACH
Factory Installed - For CTA models - 115V (Air Defrost Only)	08219551	\$5,727
Factory Installed - For CTA/CTE models - 230V/1 (Air or Electric Defrost)	08219552	
Smartgate Router (Shipped Loose)	08219541	\$3,006

*1Ø units only. **Externally mounted control enclosure**, mounted sensors and EEV

ROOM THERMOSTATS

TYPE	RANGE	LIST
Mechanical - Loose	-30°F to + 100°F	\$297
Mechanical - Installed @ Evap		\$322
Electronic - Loose	-30°F to + 100°F	\$383
Electronic - Installed @ Evap		\$402

LIQUID LINE SOLENOID VALVE - LIST PRICE EACH

HORSEPOWER RANGE	LOOSE	MTD*
1/2 thru 3 HP	\$293	\$316
4 thru 8 HP	328	366
9 thru 10 HP	474	605
12 thru 15 HP	585	754
22 HP	746	865

* Mounted at the evaporator. LLS mounted at the condensing unit is not available. For multiple evaporator systems, divide condensing unit HP by the number of evaps.

NEXT-GEN MINICON • AIR COOLED CONDENSING UNITS

1/2 THRU 6 H.P.

Standard Features (all models)

- Hermetic or Scroll compressors
- Weather resistant painted galvanized steel housing on a raised galvanized steel base
- Generously sized condenser. Enhanced Copper tubing / Aluminum fins
- Integrated subcooling loop increases system efficiency
- Easy access liquid & suction line shut off valves mounted external to cabinet
- Liquid receiver with isolation valve and pressure relief plug
- **Liquid line filter/drier and sight glass with moisture indicator**
- Suction line piping (filter optional)
- Encapsulated auto reset high pressure control

- Mild Ambient Fan Cycle control (RB models only)
- Large electrical control panel with hinged/lift off door
- Color coded wiring with point-to-point wiring diagram
- Crankcase heater
- PSC condenser fan motor(s)
- **Air Defrost Timer on all Medium Temp. models**
- **All Low temp. models include Electric Defrost provisions**
- UL and CUL listed for indoor / outdoor use
- Adjustable low pressure control for low temp models
- Encapsulated auto reset low pressure control (medium temps)

RF models also include a Flooded Head Pressure Control Valve (70°F) as a standard feature.

RV models feature the Sierra™ refrigeration system and no refrigerant receiver.

Optional Components

- Electric Defrost on Extended range med.temp models
- Suction line filter
- Mounted replaceable core liquid or suction line filter (4 to 6 HP)
- Suction Accumulator
- Oil Separator (may not be available with accumulator)
- Liquid line piping only (no filter)
- Copper or polyester coated fins
- Electro-Fin coated condenser coil
- Single Speed EC condenser mtr.
- Pump down toggle switch
- Thru-the-door disconnect switch (some models)
- External fused or non-fused disconnect
- Paragon Mechanical timer
- CPC timer
- Phase loss monitor
- Snow / Hail guards

NOMENCLATURE:

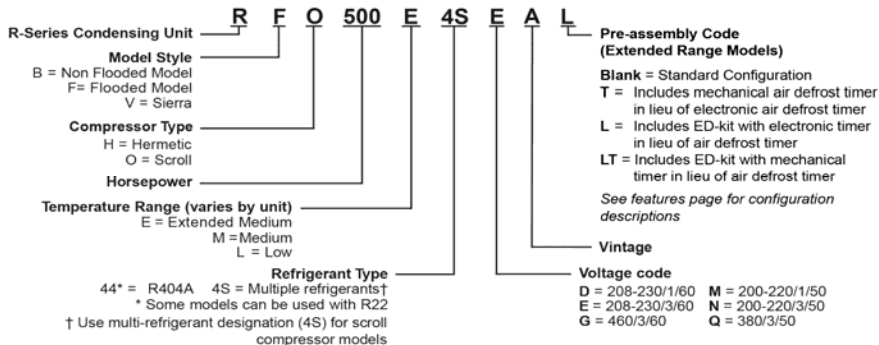

†Not all options available for Sierra models

HERMETIC COMPRESSOR MODELS

REF TYPE	NOM. H.P.	Model Number	Compressor	RF OUTDOOR FLOODED LIST PRICE			RV SIERRA UNIT LIST PRICE			RB INDOOR / OUTDOOR BASE UNIT LIST PRICE			ECM Cond. Motor Add.	4 year Compressor Protection Plan	Approx. Ship Wt. (LBS)
				(Includes Flooded Head Pressure Control Valve, Liquid Line Kit with Filter/Drier and Sight Glass with Moisture Indicator, and Defrost Timer or Kit)	(Includes Fan Cycle Head Pressure Control, Sierra Condenser Coil with Integral Receiver Section, Liquid Line Kit with Filter/Drier and Sight Glass with Moisture Indicator, and Defrost Timer or Kit)	(Includes Fan Cycle Head Pressure Control Valve, Liquid Line Kit with Filter/Drier and Sight Glass with Moisture Indicator, and Defrost Timer or Kit)	208-230V/3	208-230V/1	460V/3	208-230V/3	208-230V/1	460V/3			
EXTENDED RANGE MEDIUM TEMP R404A	0.50	R*H055E4S	RST45C1E	N/A	\$6,932	N/A	N/A	\$6,932	N/A	N/A	\$6,495	N/A	\$258	\$109 NET	152
	0.75	R*H080E4S	RST55C1E	N/A	6,990	N/A	N/A	6,990	N/A	N/A	6,580	N/A	258	109 NET	156
	0.75	R*H090E4S	RST64C1E	N/A	7,429	N/A	N/A	7,429	N/A	N/A	6,975	N/A	258	109 NET	160
	1.00	R*H100E4S	RST70C1E	\$7,691	7,778	N/A	\$7,691	7,778	N/A	\$7,205	7,293	N/A	258	109 NET	167
	1.25	R*H125E4S	RST97C1E	8,055	8,146	N/A	8,055	8,146	N/A	7,577	7,650	N/A	516	123 NET	195
	1.50	R*H150E44	CS10K6E	8,348	8,374	\$8,869	8,348	8,374	\$8,869	7,876	7,885	\$8,300	516	123 NET	205
	2.00	R*H200E44	CS12K6E	8,952	8,790	N/A	8,952	8,790	N/A	8,463	8,313	N/A	516	134 NET	228
	3.00	R*H300E44	CS18K6E	9,299	9,454	10,275	9,299	9,454	10,275	8,783	8,939	9,763	516	134 NET	235
LOW TEMP R404A	1.00	R*H100L44	CF04K6E	7,712	7,586	N/A	7,712	7,586	N/A	7,234	7,192	N/A	516	123 NET	195
	1.50	R*H150L44	CF06K6E	7,751	7,617	8,067	7,751	7,826	8,067	7,276	7,222	7,609	516	123 NET	195
	2.00	R*H200L44	CF09K6E	8,673	8,322	8,814	8,673	8,322	8,814	8,181	7,926	8,352	516	134 NET	243
	3.00	R*H300L44	CF12K6E	11,015	10,866	11,548	11,015	10,866	11,548	10,576	10,417	11,099	516	148 NET	255

§ For R507 models, use equivalent R404A model prices.

* Models 055E4S, 080E4S, and 090E4S are not suitable for use with R507. Use Scroll compressors for refrigerants other than R404A/507.

†Additional price to order optional ECM condenser fan motors. Not available for 460V.

NOTE: An optional Electric Defrost kit must be ordered in lieu of the standard Air Defrost Timer when Extended range medium temperature models are used for low temperature applications.

NEXT-GEN R-Series MINICON • AIR COOLED CONDENSING UNITS

1/2 THRU 6 H.P. Scroll Compressors

Minicon Next-Gen Scroll:

Minicon Next-Gen Air Cooled Condensing Units are configured with quiet and reliable scroll compressors.

Models range from 1/2 to 6 horsepower. Refer to page 21 for a list of optional components and publication number RU-RFH for detailed specifications.



NEXT-GEN MINICON • SCROLL CONDENSING UNITS

Temp Range	NOM H.P.	Model Number	Compressor	RF FLOODED UNIT LIST PRICE (Includes Flooded Head Pressure Control Valve, Liquid Line Kit with Filter/Drier and Sight Glass with Moisture Indicator, and Defrost Timer or Kit)*			RV SIERRA UNIT LIST PRICE (Includes Flooded Head Pressure Control Valve, Sierra System, Liquid Line Kit with Filter/Drier and Sight Glass with Moisture Indicator, and Defrost Timer or Kit)*			RB NON FLOODED UNIT LIST PRICE (Includes Liquid Line Kit with Filter/Drier and Sight Glass with Moisture Indicator, and Defrost Timer or Kit)*			EC ¹ Motor Adder	4 Year Compressor Protection Plan	Approx. Ship Wt. (LBS)	
				208-230V/3	208-230V/1	460V/3	208-230V/3	208-230V/1	460V/3	208-230V/3	208-230V/1	460V/3				
				Medium Temp	0.5	R*O060M4S	ZB06KAE	\$7,726	\$7,635	N/A	\$7,726	\$7,635				N/A
0.75	R*O080M4S	ZB07KAE	8,273		8,062	N/A	8,273	8,062	N/A	7,893	7,681	N/A	258	202	NET	195
1.0	R*O100M4S	ZB08KAE	8,372		8,213	N/A	8,372	8,213	N/A	7,991	7,828	N/A	258	202	NET	195
1.0	R*O130E4S	ZS09KAE	8,669		8,696	\$9,543	8,669	8,696	\$9,543	8,277	8,268	\$9,155	258	202	NET	195
1.25	R*O150E4S	ZS11KAE	8,812		8,755	9,774	8,812	8,755	9,774	8,416	8,330	9,379	258	202	NET	205
1.5	R*O180E4S	ZS13KAE	9,523		9,683	10,243	9,523	9,683	10,243	9,039	9,068	9,805	258	202	NET	210
2.0	R*O200E4S	ZS15KAE	9,760		9,694	10,360	9,760	9,694	10,360	9,294	9,229	9,921	258	202	NET	215
2.5	R*O250E4S	ZS19KAE	10,006		9,876	10,507	10,006	9,876	10,507	9,548	9,408	10,068	258	202	NET	230
3.0	R*O300E4S	ZS21KAE	10,755		10,572	11,205	10,755	10,572	11,205	10,349	10,178	10,824	460	263	NET	305
3.5	R*O350E4S	ZS26KAE	11,794		11,612	12,213	11,794	11,612	12,213	11,335	11,149	11,770	460	263	NET	325
Low Temp	4.0	R*O400E4S	ZS29KAE	11,540	11,771	12,693	11,540	11,771	12,693	11,127	11,319	12,284	460	275	NET	352
	4.5	R*O450E4S	ZS33KAE	12,450	12,702	13,703	12,450	12,702	13,703	12,006	12,274	13,162	460	282	NET	375
	5.0	R*O500E4S	ZS38K4E	13,437	13,291	13,853	13,437	13,291	13,853	13,044	12,894	13,432	460	282	NET	383
	6.0	R*O600E4S	ZS45K4E	14,910	N/A	15,329	14,910	N/A	15,329	14,395	N/A	14,886	460	282	NET	405
	1.0	R*O100L4S	ZF03KAE	8,918	8,800	N/A	8,918	8,800	N/A	8,326	8,323	N/A	258	202	NET	195
	1.3	R*O130L4S	ZF04KAE	9,306	9,183	N/A	9,306	9,183	N/A	8,782	8,739	N/A	258	202	NET	195
	1.5	R*O160L4S	ZF05KAE	9,723	9,594	N/A	9,723	9,594	N/A	9,247	9,171	N/A	258	202	NET	195
	2.3	R*O230L4S	ZF07K4E	10,318	10,180	N/A	10,318	10,180	N/A	9,915	9,781	N/A	258	202	NET	230
	2.5	R*O250L4S	ZF08K4E	11,190	10,994	12,065	11,190	10,994	12,065	10,810	10,613	11,462	258	202	NET	240
	3.0	R*O300L4S	ZF09K4E	11,598	11,386	12,271	11,598	11,386	12,271	11,217	11,259	11,837	258	263	NET	245
3.5	R*O350L4S	ZF11K4E	12,722	12,580	13,140	12,722	12,580	13,140	12,341	12,161	12,760	258	263	NET	255	
4.0	R*O400L4S	ZF13K4E	14,317	14,174	14,518	14,317	14,174	14,518	13,936	13,794	14,138	460	275	NET	352	
5.0	R*O500L4S	ZF15K4E	14,726	14,647	14,969	14,726	14,647	14,969	14,346	14,200	14,588	460	275	NET	367	
6.0	R*O600L4S	ZF18K4E	15,582	N/A	15,832	15,582	N/A	15,832	15,202	N/A	15,451	460	282	NET	383	

¹ Additional list price to order optional ECM condenser fan motors. Not available for 460V.

* See page 19 for a complete list of features, voltage codes and an example of nomenclature layout.

NOTE: An optional Electric Defrost kit must be ordered in lieu of the standard Air Defrost Timer when Extended Range Medium Temperature Models are used for low temperature applications.

LEGACY MINICON / R-SERIES • AIR COOLED CONDENSING UNITS

Standard features for Legacy RE style Indoor / Outdoor models:

- Semi-hermetic compressors
- Heavy gauge galvanized steel weather-proof housing on a raised base
- Compressor Contactor (three phase) or Start Kit (single phase)
- Main Power Block and Control Circuit Fuses
- High-low Pressure Control and Oil Pressure Control (when required)
- Liquid Receiver with Shut-off Valve and Pressure Relief Plug
- Liquid and suction line piping (filters are optional)
- PSC condenser fan motor(s)
- UL and cUL listed.

Standard features for Legacy RL style models:

- Same features as RE models, plus:
- Liquid Line Filter/Drier, Sight Glass & Pre-bent Piping
- Crankcase Heater
- Low ambient Head Pressure Valve.
- Air Defrost Timer on 2-1/2 to 3 H.P. Medium & High Temp models
- Electric Defrost Timer with Defrost Contactor/Relay on Low Temp models (ED10-230V/1 on 1/2 thru 3 HP)

SEMI-HERMETIC COMPRESSOR MODELS

REF TYPE	NOM H.P.	Model Number	Compressor	RL OUTDOOR PACKAGE LIST PRICE			RE INDOOR/ OUTDOOR LIST PRICE			4 Year Compressor Protection Plan	Approx. Ship Wt (LBS)	EC ¹ Motor Adder	
				208-230V/3	208-230V/1	460V/3	208-230V/3	208-230V/1	460V/3				
MEDIUM TEMP R404A	0.75	R*S075M44	KAN-007E	\$8,336	\$8,336	N/A	\$7,369	\$7,369	N/A	\$202	NET	215	\$258
	1.0	R*S100M44	KAR-010E	8,583	8,583	N/A	7,076	7,076	N/A	202	NET	220	258
	1.5	R*S150M44	KAG-010E	10,388	N/A	N/A	8,484	N/A	N/A	202	NET	245	516
	2.0	R*S200M44	KAK-02xE	12,197	12,197	N/A	10,556	10,556	N/A	202	NET	270	516
	2.5	R*S250M44	ERC-02xE	12,680	N/A	13,867	12,188	N/A	\$13,296	202	NET	194	516
	3.0	R*S300M44	ERF-031E	14,196	14,565	14,863	13,042	13,408	13,891	263	NET	415	516
LOW TEMP R404A	0.50	R*S050L44	KAN-005E	8,927	8,927	N/A	6,500	6,276	N/A	202	NET	189	258
	0.75	R*S075L44	KAM-007E	9,585	9,585	N/A	6,847	6,658	N/A	202	NET	205	258
	1.0	R*S100L44	KAJ-01xE	10,024	10,024	10,376	7,548	7,534	7,840	202	NET	220	258
	1.5	R*S150L44	KAL-01xE	10,459	10,296	11,440	8,813	8,670	10,296	202	NET	248	516
	2.0	R*S200L44	EAV-021E	12,906	12,976	13,669	10,727	10,886	12,837	202	NET	290	516
	3.0	R*S300L44*	LAH-032E	14,344	14,344	14,759	12,898	13,190	13,917	263	NET	383	516

* Model R*S300L44 is not available for 208V/1 (230V only).

¹ Additional list price to order optional Electronically Commutated condenser fan motors. Not available for 460V.

MINICON WITH DISC COMPRESSOR

No Longer Available. Select Next Gen II model - See Page 22

NEXT-GEN MINICON / LEGACY R-SERIES • AIR COOLED CONDENSING UNITS
1/2 THRU 6 H.P.

FACTORY INSTALLED OPTIONS

OPTIONS / ACCESSORIES	OPTION NUMBER	H.P. RANGE	RF MODELS	RV MODELS	RB MODELS	RL PACKAGE	RE MODELS
CRANKCASE HEATER	CCH-1	1/2 - 6 H.P.	STD.	STD.	STD.	STD.	\$215
DEDUCT CRANKCASE HEATER	CCH-DED	1/2 - 6 H.P.	-\$215	-\$215	-\$215	-\$215	N/A
LIQUID LINE COMPONENTS	LK-MC1	1/2 - 3 H.P.	STD.	STD.	STD.	STD.	539
- Filter drier, sight-glass and piping	LK-MC2	4 - 6 H.P.	STD.	STD.	STD.	STD.	626
LIQUID LINE ONLY (Deduct liquid line filter and sight glass)	LL-MC1	1/2 - 3 H.P.	-344	N/A	-344	N/A	STD.
	LL-MC2	4 - 6 H.P.	-409	N/A	-409	N/A	STD.
Replaceable Core Liquid Filter/Dryer (4 - 6 H.P. only) Must add LK for RE unit	RPL-4	4 - 6 H.P.	506	506	506	506	506
SUCTION LINE COMPONENTS	SK-MC1	1/2 - 3 H.P.	344	344	344	344	344
- Filter and Piping	SK-MC2	4 - 6 H.P.	409	409	409	409	409
REPLACEABLE CORE SUCTION FILTER (4 - 6 H.P. only)	RPS-4	4 - 6 H.P.	489	489	489	489	489
SUCTION LINE ACCUMULATOR - Must add SK option	ASK-3	1/2 - 2 HP	529†	529†	529†	529†	529†
	ASK-4	2½ - 6 H.P.	817†	817†	817†	817†	817†
OIL SEPARATOR 4-6 HP (Due to space limits, may not be available with ASK opt)	OS-4	4 - 6 H.P.	1,391	1,391	1,391	1,391	1,391
OVER-SIZED RECEIVER – Refers to Next Gen CU frame sizes FM1 through FM4. See product catalogue for details. Contact factory for Legacy model oversized receiver prices.	OSR-1	FM1	439	N/A	439	Contact Application Engineering for pricing this option	
	OSR-2	FM2	523	N/A	523		
	OSR-3	FM3	1,251	N/A	1,251		
	OSR-4	FM4	1,284	N/A	1,284		
SPRING MOUNT AND DISCHARGE VIBRASORBER - Semi-Hermetics only. - Standard on 4 - 6 H.P. models,	SPR-VB	1/2 - 3 H.P.	N/A	N/A	N/A	264	264
		4 - 6 H.P.	N/A	N/A	N/A	NLA	NLA
LOW AMBIENT FLOODED HEAD PRESSURE CONTROL	FLD-SF	1/2 - 2 H.P.	STD.	N/A	N/A	STD.	382
	FLD-F	2½ - 3 H.P.	STD.	N/A	N/A	STD.	382
MILD AMBIENT FAN CYCLE	FC-1	RB all, RE 2 fan only	N/A	N/A	STD.	N/A	374
ADJUSTABLE LOW PRESSURE CONTROL (For medium temperature units)	ADJ-LP	1/2 - 6 H.P.	160	160	160	160	160
ADJUSTABLE HI/LOW PRESSURE CONTROL	204464041	1/2 - 6 H.P.	358	358	358	358	358
PUMPDOWN TOGGLE SWITCH	PS	1/2 - 6 H.P.	337	N/A	337	337	337
AIR DEFROST TIMER ¹ (Electronic timer is standard. No additional charge to substitute mechanical timer. Specify at time of order.)	TMR ¹	1/2 - 6 H.P.	STD.	STD.	STD.	577	577
DEDUCT AIR DEFROST TIMER ¹	DEDUCT TMR ¹	2 1/2 - 6 H.P.	-577	-577	-577	-577	N/A
SUBSTITUTE ED KIT (ED5 THRU ED10) FOR AIR DEFROST TIMER ²	REPLACE TMR ²	1 - 6 H.P. ²	119	119	119	N/A	N/A
ELEC. DEFR. TIMER WITH BLOCK-OUT RELAY 230/1 ^{††}	ED-5 THRU ED-10	1/2 - 6 H.P.	STD.*	STD.*	STD.*	STD.*	695
2 EVAP ELEC. DEFR. TIMER WITHOUT BLOCK-OUT RELAY 230/1 ^{††}	ED-210-A2	1/2 - 6 H.P.	SPECIFY	SPECIFY	SPECIFY	SPECIFY	695
ELECTRIC DEFR. TIMER WITH BLOCK-OUT AND CONTACTOR 230/3 ^{††}	ED-11-B2	1/2 - 6 H.P.	STD.*	STD.*	STD.*	STD.*	695
DEDUCT STANDARD EVAP ELECTRIC DEFROST COMPONENTS		1/2 - 6 H.P.	-695	-695	-695	-695	N/A
** 2 EVAP ELEC. DEFR. TMR WITH ONE 30 AMP DEFR. CONTACTOR 230/3 ^{††}	ED-211-B2	1/2 - 6 H.P.	SPECIFY	SPECIFY	SPECIFY	SPECIFY	695
2 EVAP ELEC. DEFR. TMR WITH ONE 50 AMP DEFR. CONTACTOR 230/3 ^{††}	ED-213-B2	1/2 - 6 H.P.	772	772	772	772	1,348
2 EVAP. ELEC. DEFR. WITH SEQUENCING & B.O. RELAYS 230/1 ^{††}	ED-20-A2	4 - 6 H.P.	1,230	1,230	1,230	1,230	1,925
2 EVAP. ELEC. DEFR. WITH SEQ. & B.O. W/ CONTACTORS 230/3 ^{††}	ED-21-B2	4 - 6 H.P.	1,230	1,230	1,230	1,230	1,925
HEATED AND INSULATED RECEIVER	HIR	1/2 - 6 H.P.	717	N/A	717	717	717
PHASE LOSS MONITOR	PLM	1/2 - 6 H.P.	1,175	1,175	1,175	1,175	1,175
CRANKCASE PRESSURE REGULATING VALVE - (LOOSE ONLY)	CPR-1	1/2 - 6 H.P.	782	782	782	782	782
POLYESTER COATED CONDENSER FINS	PCF	1/2 - 3 H.P.	996	996	996	996	996
		4 - 6 H.P.	1,295	1,295	1,295	1,295	1,295
COPPER FINS OR ELECTRO FIN COATED COIL	CONTACT APPLICATIONS ENGINEERING FOR PRICING						
THRU THE DOOR NON - FUSED DISCONNECT SWITCH	TDNM-1	1/2 - 3 H.P.	504	504	504	504	504
	TDNM-2	4 - 6 H.P.	669	669	669	669	669
THRU THE DOOR FUSED DISCONNECT SWITCH	TDFM-1	1/2 - 3 H.P.	N/A	N/A	N/A	N/A	N/A
	TDFM-2	4 - 6 H.P.	1,371	1,371	1,371	1,371	1,371
EXTERNAL FUSED DISCONNECT (Mounted)	EFDM-1	1/2 - 3 H.P.	567	567	567	567	567
	EFDM-2	4 - 6 H.P.	1,043	1,043	1,043	1,043	1,043

FIELD INSTALLED OPTIONS

OPTIONS AND ACCESSORIES		H.P. RANGE	RF MODELS	RV MODELS	RB MODELS	RL MODELS	RE MODELS
EXTERNAL FUSED DISCONNECT (Shipped loose)	EFDL-2	4 - 6 H.P.	\$938	\$938	\$938	\$938	\$938
TWO TIERED STACKING RACK	08357263	1/2 - 3 H.P.	10,322	10,322	10,322	C/F	C/F
	08357286	4 - 6 H.P.	10,322	10,322	10,322	C/F	C/F
SNOW / HAIL GUARDS (Shipped loose)	SG-A	Config. A, FM1	385	385	385	385	385
	SG-B	Config. B, FM2	424	424	424	424	424
	SG-C	Config. C, FM3	459	459	459	459	459
	SG-D	Config. D, FM4	563	563	563	563	563

Negative numbers represent the price to be deducted from base price if a standard feature is removed.

¹ AIR DEFROST TIMER IS STANDARD ON 2-1/2 - 6 HP HIGH/MEDIUM TEMP RL MODELS AND STANDARD FOR ALL RF AND RB MED. TEMP. MODELS

² SUBSTITUTE ED KIT (ED5 THRU ED10) FOR AIR DEFROST TIMER. VALID FOR NEXT-GEN EXTENDED RANGE MINICONS ONLY. APPLIES TO PRE-ASSEMBLY CODES L AND LT. SEE NOMENCLATURE ON PAGE 19.

*ELECTRIC DEFROST PROVISIONS (ED KIT) FOR ONE EVAP IS A STANDARD FEATURE ON LOW TEMPERATURE UNITS (ED Kits are optional for RE models).

†† REFER TO THE APPROPRIATE EVAPORATOR PRODUCT BULLETIN TO IDENTIFY THE CORRECT E.D. KIT FOR YOUR REQUIREMENT.

NOT ALL E.D. KITS FIT INTO ALL CONTROL PANELS. CONTACT APPLICATIONS ENGINEERING WITH QUESTIONS.

† MUST ADD SK OPTION TO ADD A SUCTION LINE ACCUMULATOR IF SK IS NOT ALREADY INCLUDED (See R-Series publication for details).

NOTE: NOT ALL OPTIONS ARE AVAILABLE FOR SIERRA CONDENSING UNITS. CONTACT YOUR RUSSELL REPRESENTATIVE FOR A SPECIAL PRICE QUOTE.

NEXT-GEN II AIR COOLED CONDENSING UNITS

3 THRU 22 H.P.

Standard Features (all models):

- Copeland Discus™, Copeland Scroll™ or Bitzer Semi-Hermetic Compressor
- All weather G90 galvanized steel painted enclosure
- Removable side panels for ease of service
- Generously sized high efficiency condenser, with enhanced copper tubes/and aluminum fins
- Liquid line kit with sealed filter/drier and sight glass with moisture indicator
- Easy access base mounted service valves placed external to cabinet
- Dual pressure (auto reset) controls with flexible Refflex® hoses
- Vertical receiver with isolation valves
- Refrigerant pressure relief valve (Larger models in FD2 and FD3 cabinets)
- Integral liquid subcooling circuit
- Suction line piping (filter optional)
- Heavy duty three phase condenser fan motor(s)
- Crankcase heater
- Control circuit fuses
- Pump down toggle switch
- Large electrical panel with hinged door
- 208-230V control voltage
- Color coded point-to-point wiring
- Fan cycling on RB models
- Liquid injection / Demand Cooling™ for low temp compressors

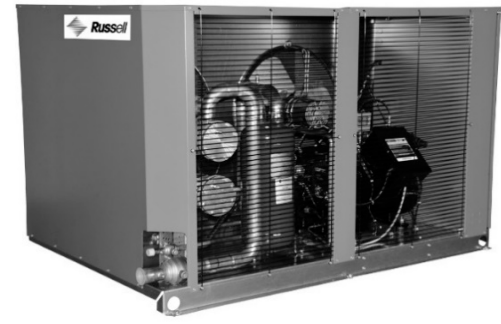

Unit is shown with optional components mounted

RF models also include a Flooded Head Pressure Control Valve (70°F) as a standard feature

Optional Features (all models):

- Electronic air defrost timer
- Electric defrost kits
- Mechanical timer in lieu of electronic timer
- 50 Hz timer and/or defrost kit
- Current sensing relay
- Thru the door Non-fused disconnect
- Suction line filter (sealed)
- Suction accumulator
- Oil separator
- Replaceable core liquid filter with bypass
- Replaceable core suction filter with bypass
- External fused or non-fused disconnect - loose or mounted
- Heated and insulated receiver (Temp controlled with low pressure bypass timer)
- Refrigerant pressure relief valve (for models in FD1 cabinet).
- Oversized receiver
- Insulated receiver
- Hail / Snow Guard - shipped loose (only)
- 316 Grade stainless steel housing
- Crankcase pressure regulator

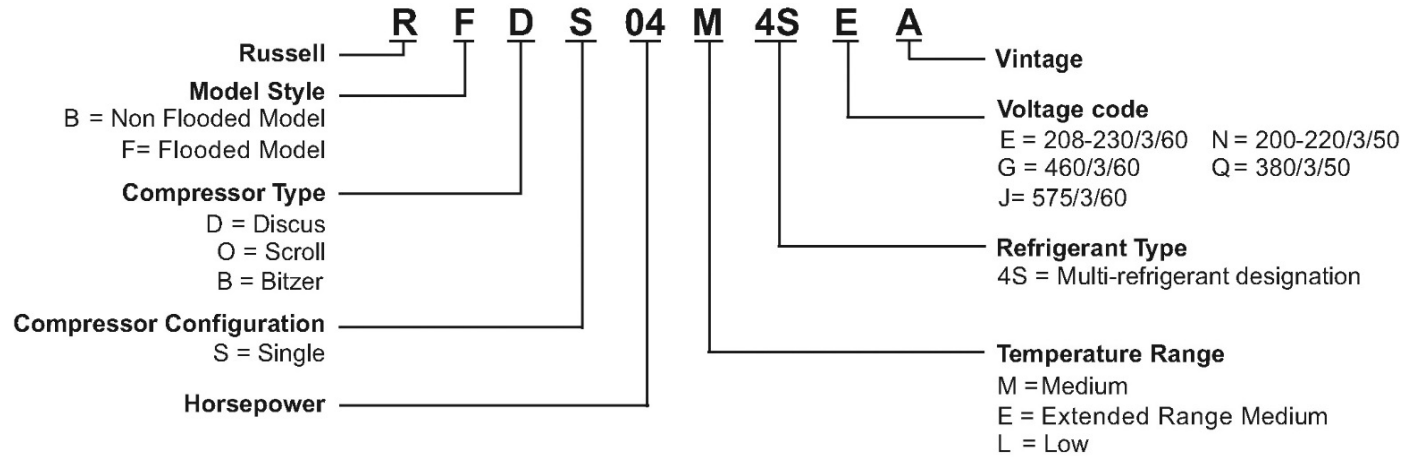

Temp Range	Compressor (Discus™)	H.P.	Model Number	RF	VOLTAGE	Model Number	RB	4 Year Compressor Protection Plan	Approx. Ship Wt. (LBS)
				Flooded Unit List Price			Non Flooded List Price		
Medium Temp Discus	2DC3R53K	04	RFDS04M4SEA	\$22,032	208/230/3/60	RBDS04M4SEA	\$21,012	\$472 NET	825
			RFDS04M4SGA	23,404	460/3/60	RBDS04M4SGA	22,383		
			RFDS04M4SJA	23,873	575/3/60	RBDS04M4SJA	22,853		
	2DD3R63K	05	RFDS05M4SEA	22,430	208/230/3/60	RBDS05M4SEA	21,408	472 NET	850
			RFDS05M4SGA	23,745	460/3/60	RBDS05M4SGA	22,724		
			RFDS05M4SJA	24,342	575/3/60	RBDS05M4SJA	23,321		
	2DL3R78K	06	RFDS06M4SEA	27,857	208/230/3/60	RBDS06M4SEA	26,836	572 NET	1,075
			RFDS06M4SGA	29,796	460/3/60	RBDS06M4SGA	28,776		
			RFDS06M4SJA	30,389	575/3/60	RBDS06M4SJA	29,369		
	2DA3R89K	07	RFDS07M4SEA	28,448	208/230/3/60	RBDS07M4SEA	27,427	580 NET	1,100
			RFDS07M4SGA	30,188	460/3/60	RBDS07M4SGA	29,167		
			RFDS07M4SJA	30,782	575/3/60	RBDS07M4SJA	29,761		
	3DA3R10M	08	RFDS08M4SEA	31,904	208/230/3/60	RBDS08M4SEA	30,884	580 NET	1,130
			RFDS08M4SGA	33,816	460/3/60	RBDS08M4SGA	32,794		
			RFDS08M4SJA	34,505	575/3/60	RBDS08M4SJA	33,484		
	3DB3R12M	10	RFDS10M4SEA	34,212	208/230/3/60	RBDS10M4SEA	33,191	750 NET	1,330
			RFDS10M4SGA	35,983	460/3/60	RBDS10M4SGA	34,962		
			RFDS10M4SJA	36,646	575/3/60	RBDS10M4SJA	35,625		
	3DF3R15M	12	RFDS12M4SEA	37,060	208/230/3/60	RBDS12M4SEA	36,039	900 NET	1,330
			RFDS12M4SGA	38,511	460/3/60	RBDS12M4SGA	37,490		
			RFDS12M4SJA	N/A	575/3/60	RBDS12M4SJA	N/A		
	3DS3R17M	15	RFDS15M4SEA	38,612	208/230/3/60	RBDS15M4SEA	37,592	1,161 NET	1,350
			RFDS15M4SGA	39,916	460/3/60	RBDS15M4SGA	38,895		
			RFDS15M4SJA	40,594	575/3/60	RBDS15M4SJA	39,573		

Voltage codes: E = 208-230/3/60, G = 460V/3/60, J = 575V/3/60

* See next page for condensing units with low temp Discus™ or Scroll™ compressors.

NEXT-GEN II AIR COOLED CONDENSING UNITS

3 THRU 22 H.P. - DISCUS™ and SCROLL™

Temperature Range	Compressor (Discus™)	H.P.	Model Number	RF Flooded List Price	VOLTAGE	Model Number	RB Non Flooded List Price	4 Year Compressor Protection Plan	Approx. Ship Wt. (LBS)
Low Temp Discus	2DF3F16K	03	RFDS03L4SEA	\$24,483	208/230/3/60	RBDS03L4SEA	\$23,461	\$318 NET	710
			RFDS03L4SGA	25,997	460/3/60	RBDS03L4SGA	24,976		
			RFDS03L4SJA	26,549	575/3/60	RBDS03L4SJA	25,529		
	2DL3F20K	04	RFDS04L4SEA	26,589	208/230/3/60	RBDS04L4SEA	25,567	472 NET	760
			RFDS04L4SGA	28,125	460/3/60	RBDS04L4SGA	27,103		
			RFDS04L4SJA	28,622	575/3/60	RBDS04L4SJA	27,601		
	2DA3F23K	05	RFDS05L4SEA	27,167	208/230/3/60	RBDS05L4SEA	26,146	472 NET	805
			RFDS05L4SGA	28,912	460/3/60	RBDS05L4SGA	27,891		
			RFDS05L4SJA	29,433	575/3/60	RBDS05L4SJA	28,412		
	3DA3F28K	06	RFDS06L4SEA	29,387	208/230/3/60	RBDS06L4SEA	28,367	572 NET	870
			RFDS06L4SGA	31,145	460/3/60	RBDS06L4SGA	30,125		
			RFDS06L4SJA	31,845	575/3/60	RBDS06L4SJA	30,824		
	3DB3F33K	08	RFDS08L4SEA	32,585	208/230/3/60	RBDS08L4SEA	31,564	580 NET	1,130
			RFDS08L4SGA	34,004	460/3/60	RBDS08L4SGA	32,983		
			RFDS08L4SJA	35,079	575/3/60	RBDS08L4SJA	34,058		
	3DF3F40K	09	RFDS09L4SEA	36,152	208/230/3/60	RBDS09L4SEA	35,132	750 NET	1,275
			RFDS09L4SGA	38,135	460/3/60	RBDS09L4SGA	37,113		
			RFDS09L4SJA	38,838	575/3/60	RBDS09L4SJA	37,816		
	3DS3F46K	10	RFDS10L4SEA	39,022	208/230/3/60	RBDS10L4SEA	38,001	854 NET	1,275
			RFDS10L4SGA	39,651	460/3/60	RBDS10L4SGA	38,630		
			RFDS10L4SJA	40,579	575/3/60	RBDS10L4SJA	39,557		
	4DBNF54K	12	RFDS12L4SEA	39,745	208/230/3/60	RBDS12L4SEA	38,724	900 NET	1,290
			RFDS12L4SGA	40,592	460/3/60	RBDS12L4SGA	39,571		
			RFDS12L4SJA	41,356	575/3/60	RBDS12L4SJA	40,334		
4DHNF63K	15	RFDS15L4SEA	41,638	208/230/3/60	RBDS15L4SEA	40,621	1,161 NET	1,310	
		RFDS15L4SGA	42,259	460/3/60	RBDS15L4SGA	41,239			
		RFDS15L4SJA	43,092	575/3/60	RBDS15L4SJA	42,071			
4DJNF76K	22	RFDS22L4SEA	46,842	208/230/3/60	RBDS22L4SEA	45,820	1,437 NET	1,420	
		RFDS22L4SGA	47,582	460/3/60	RBDS22L4SGA	46,561			
		RFDS22L4SJA	48,726	575/3/60	RBDS22L4SJA	47,706			

Temperature Range	Compressor (Scroll™)	H.P.	Model Number	RF Flooded LIST PRICE	VOLTAGE	Model Number	RB Non Flooded List Price	4 Year Compressor Protection Plan	Approx. Ship Wt. (LBS)
Medium Temp Scroll	ZS29KAE	04	RFOS04E4SEA	\$20,249	208/230/3/60	RBOS04E4SEA	\$19,229	\$275 NET	700
			RFOS04E4SGA	21,848	460/3/60	RBOS04E4SGA	20,828		
			RFOS04E4SJA	22,322	575/3/60	RBOS04E4SJA	21,300		
	ZS33KAE	05	RFOS05E4SEA	20,610	208/230/3/60	RBOS05E4SEA	19,588	275 NET	710
			RFOS05E4SGA	22,181	460/3/60	RBOS05E4SGA	21,160		
			RFOS05E4SJA	22,718	575/3/60	RBOS05E4SJA	21,696		
	ZS38K4E	06	RFOS06E4SEA	23,485	208/230/3/60	RBOS06E4SEA	22,464	282 NET	710
			RFOS06E4SGA	25,369	460/3/60	RBOS06E4SGA	24,347		
			RFOS06E4SJA	25,902	575/3/60	RBOS06E4SJA	24,882		
	ZS45K4E	07	RFOS07E4SEA	23,943	208/230/3/60	RBOS07E4SEA	22,922	466 NET	870
			RFOS07E4SGA	25,726	460/3/60	RBOS07E4SGA	24,705		
			RFOS07E4SJA	26,261	575/3/60	RBOS07E4SJA	25,240		
	ZB58K5E	08	RFOS08E4SEA	24,416	208/230/3/60	RBOS08E4SEA	23,396	466 NET	915
			RFOS08E4SGA	26,220	460/3/60	RBOS08E4SGA	25,199		
			RFOS08E4SJA	26,790	575/3/60	RBOS08E4SJA	25,769		
	ZB66K5E	09	RFOS09E4SEA	25,769	208/230/3/60	RBOS09E4SEA	24,749	504 NET	980
			RFOS09E4SGA	27,382	460/3/60	RBOS09E4SGA	26,361		
			RFOS09E4SJA	27,926	575/3/60	RBOS09E4SJA	26,905		
	ZB76K5E	10	RFOS10E4SEA	30,127	208/230/3/60	RBOS10E4SEA	29,105	504 NET	1,085
			RFOS10E4SGA	31,272	460/3/60	RBOS10E4SGA	30,250		
			RFOS10E4SJA	31,914	575/3/60	RBOS10E4SJA	30,893		
	ZB95K5E	13	RFOS13E4SEA	33,365	208/230/3/60	RBOS13E4SEA	32,345	582 NET	1,105
			RFOS13E4SGA	33,442	460/3/60	RBOS13E4SGA	32,421		
			RFOS13E4SJA	34,535	575/3/60	RBOS13E4SJA	33,514		
ZB114K5E	15	RFOS15E4SEA	37,254	208/230/3/60	RBOS15E4SEA	36,233	594 NET	1,200	
		RFOS15E4SGA	38,955	460/3/60	RBOS15E4SGA	37,934			
		RFOS15E4SJA	39,716	575/3/60	RBOS15E4SJA	38,694			

Low Temp Scroll	ZF25K4E	08	RFOS08L4SEA	\$23,073	208/230/3/60	RBOS08L4SEA	\$22,052	\$466 NET	850
			RFOS08L4SGA	24,438	460/3/60	RBOS08L4SGA	23,417		
			RFOS08L4SJA	24,916	575/3/60	RBOS08L4SJA	23,895		
	ZF34K5E	10	RFOS10L4SEA	28,640	208/230/3/60	RBOS10L4SEA	27,618	504 NET	1,025
			RFOS10L4SGA	30,324	460/3/60	RBOS10L4SGA	29,303		
			RFOS10L4SJA	30,946	575/3/60	RBOS10L4SJA	29,925		
	ZF41K5E	13	RFOS13L4SEA	32,370	208/230/3/60	RBOS13L4SEA	31,349	582 NET	1,050
			RFOS13L4SGA	32,924	460/3/60	RBOS13L4SGA	31,903		
			RFOS13L4SJA	33,821	575/3/60	RBOS13L4SJA	32,800		
	ZF49K5E	15	RFOS15L4SEA	33,445	208/230/3/60	RBOS15L4SEA	32,425	594 NET	1,105
			RFOS15L4SGA	34,200	460/3/60	RBOS15L4SGA	33,180		
			RFOS15L4SJA	34,884	575/3/60	RBOS15L4SJA	33,862		

Voltage codes: E = 208-230/3/60, G = 460V/3/60, J = 575V/3/60

* See next Page for Condensing units with Bitzer Compressors

**NEXT-GEN II AIR COOLED CONDENSING UNITS
3 THRU 22 H.P. - BITZER**

Temperature Range	Compressor (Bitzer)	H.P.	Model Number	RF Flooded List Price	VOLTAGE	Model Number	RB Non Flooded List Price	4 Year Compressor Protection Plan	Approx. Ship Wt. (LBS)
Medium Temp Bitzer	2DES-3	03	RFBS03E4SEA	\$24,177	208/230/3/60	RBBS03E4SEA	\$23,156	\$472 NET	800
			RFBS03E4SGA	25,762	460/3/60	RBBS03E4SGA	24,741		
			RFBS03E4SJA	26,001	575/3/60	RBBS03E4SJA	24,980		
	2CES-4	04	RFBS04E4SEA	24,558	208/230/3/60	RBBS04E4SEA	23,536	472 NET	825
			RFBS04E4SGA	26,086	460/3/60	RBBS04E4SGA	25,065		
			RFBS04E4SJA	26,457	575/3/60	RBBS04E4SJA	25,435		
	4FES-5	05	RFBS05E4SEA	24,954	208/230/3/60	RBBS05E4SEA	23,934	472 NET	850
			RFBS05E4SGA	26,427	460/3/60	RBBS05E4SGA	25,406		
			RFBS05E4SJA	26,914	575/3/60	RBBS05E4SJA	25,893		
	4EES-6	06	RFBS06E4SEA	27,352	208/230/3/60	RBBS06E4SEA	26,331	572 NET	1,075
			RFBS06E4SGA	28,385	460/3/60	RBBS06E4SGA	27,363		
			RFBS06E4SJA	30,218	575/3/60	RBBS06E4SJA	29,197		
	4DES-7	07	RFBS07E4SEA	29,716	208/230/3/60	RBBS07E4SEA	28,696	580 NET	1,100
			RFBS07E4SGA	30,309	460/3/60	RBBS07E4SGA	29,288		
			RFBS07E4SJA	33,489	575/3/60	RBBS07E4SJA	32,468		
	4CES-9	08	RFBS08E4SEA	33,489	208/230/3/60	RBBS08E4SEA	32,468	580 NET	1,130
			RFBS08E4SGA	35,163	460/3/60	RBBS08E4SGA	34,142		
			RFBS08E4SJA	35,920	575/3/60	RBBS08E4SJA	34,898		
	4TES-12	10	RFBS10E4SEA	33,893	208/230/3/60	RBBS10E4SEA	32,871	750 NET	1,330
			RFBS10E4SGA	35,895	460/3/60	RBBS10E4SGA	34,873		
			RFBS10E4SJA	36,557	575/3/60	RBBS10E4SJA	35,537		
	4PES-15	12	RFBS12E4SEA	35,333	208/230/3/60	RBBS12E4SEA	34,312	900 NET	1,330
			RFBS12E4SGA	37,175	460/3/60	RBBS12E4SGA	36,155		
			RFBS12E4SJA	37,838	575/3/60	RBBS12E4SJA	36,817		
4NES-20	15	RFBS15E4SEA	36,137	208/230/3/60	RBBS15E4SEA	35,116	1,161 NET	1,350	
		RFBS15E4SGA	37,905	460/3/60	RBBS15E4SGA	36,885			
		RFBS15E4SJA	38,564	575/3/60	RBBS15E4SJA	37,543			

Low Temp Bitzer	4FES-3	03	RFBS03L4SEA	\$24,060	208/230/3/60	RBBS03L4SEA	\$23,040	\$292 NET	710
			RFBS03L4SGA	24,901	460/3/60	RBBS03L4SGA	23,880		
			RFBS03L4SJA	25,438	575/3/60	RBBS03L4SJA	24,417		
	4EES-4	04	RFBS04L4SEA	26,183	208/230/3/60	RBBS04L4SEA	25,162	292 NET	760
			RFBS04L4SGA	27,023	460/3/60	RBBS04L4SGA	26,002		
			RFBS04L4SJA	27,561	575/3/60	RBBS04L4SJA	26,540		
	4DES-5	05	RFBS05L4SEA	27,379	208/230/3/60	RBBS05L4SEA	26,358	324 NET	805
			RFBS05L4SGA	28,307	460/3/60	RBBS05L4SGA	27,286		
			RFBS05L4SJA	28,827	575/3/60	RBBS05L4SJA	27,805		
	4CES-6	06	RFBS06L4SEA	32,283	208/230/3/60	RBBS06L4SEA	31,262	337 NET	870
			RFBS06L4SGA	33,486	460/3/60	RBBS06L4SGA	32,465		
			RFBS06L4SJA	33,841	575/3/60	RBBS06L4SJA	32,819		
	4TES-9	08	RFBS08L4SEA	34,348	208/230/3/60	RBBS08L4SEA	33,327	337 NET	1,130
			RFBS08L4SGA	35,504	460/3/60	RBBS08L4SGA	34,483		
			RFBS08L4SJA	35,965	575/3/60	RBBS08L4SJA	34,944		
	4PES-12	09	RFBS09L4SEA	36,590	208/230/3/60	RBBS09L4SEA	35,569	337 NET	1,275
			RFBS09L4SGA	37,681	460/3/60	RBBS09L4SGA	36,660		
			RFBS09L4SJA	38,706	575/3/60	RBBS09L4SJA	37,684		
	4NES-14	10	RFBS10L4SEA	38,865	208/230/3/60	RBBS10L4SEA	37,844	337 NET	1,275
			RFBS10L4SGA	39,956	460/3/60	RBBS10L4SGA	38,934		
			RFBS10L4SJA	40,980	575/3/60	RBBS10L4SJA	39,959		
	4JE-15	12	RFBS12L4SEA	41,686	208/230/3/60	RBBS12L4SEA	40,665	457 NET	1,290
			RFBS12L4SGA	42,777	460/3/60	RBBS12L4SGA	41,757		
			RFBS12L4SJA	43,802	575/3/60	RBBS12L4SJA	42,781		
4HE-18	15	RFBS15L4SEA	44,573	208/230/3/60	RBBS15L4SEA	43,552	567 NET	1,310	
		RFBS15L4SGA	45,661	460/3/60	RBBS15L4SGA	44,640			
		RFBS15L4SJA	46,689	575/3/60	RBBS15L4SJA	45,667			
4GE-23	22	RFBS22L4SEA	46,098	208/230/3/60	RBBS22L4SEA	42,459	645 NET	1,420	
		RFBS22L4SGA	47,251	460/3/60	RBBS22L4SGA	46,230			
		RFBS22L4SJA	48,279	575/3/60	RBBS22L4SJA	47,258			

Voltage codes: E = 208-230/3/60, G = 460V/3/60, J = 575V/3/60

3 THRU 22 H.P. CONDENSING UNITS - FACTORY INSTALLED DEFROST KITS

1 EVAPORATOR PER CU	Max Defrost Load	List Price
DMA15	15	\$1,324
DMA20	20	
DMA24	24	
DMA30	30	
DMA35	35	1,478
DMA40	40	
DMA48	48	
DMB60	60	2,884
DMB96	96	

2 EVAPS PER CU	Max Defrost Load	List Price
DMB35	35	\$2,005
DMB40	40	
DMB48	48	
DMB60	60	2,884
DMB96	96	

3 EVAPS PER CU	Max Defrost Load	List Price
DMC35	35	\$3,016
DMC40	40	
DMC48	48	
DMC60	60	3,729
DMC96	96	

AIR DEFROST TIMER	\$577
--------------------------	--------------

Note: All electric defrost kits include 1 fan contactor and are suitable for single or three phase loads. Defrost amp values are the maximum load for a kit. Smaller loads may be attached.

3 THRU 22 H.P. CONDENSING UNITS - FACTORY INSTALLED OPTIONS

All options are factory mounted unless otherwise noted.	OPTION NUMBER	H.P. RANGE	LIST PRICE [†]
Electrical options			
THROUGH THE DOOR NON-FUSED DISCONNECT SWITCH	TDNM-3	3-10	\$1,614
	TDNM-4	12-22	1,804
EXTERNAL FUSED DISCONNECT - Loose or Mounted	EFDM-2 (230V)	3 - 6	1,043
	EFDM-3 (230V)	7 - 10	1,242
	EFDM-4 (230V)	12 - 22	2,648
	EFDM-2 (460V)	3 - 6	1,226
	EFDM-3 (460V)	7 - 10	2,207
	EFDM-4 (460V)	12 - 22	3,641
MAIN CIRCUIT BREAKER	BKR-2	3 - 6	1,491
	BKR-3	7 - 10	1,877
	BKR-4	12 - 22	2,362
† PHASE LOSS MONITOR	PLM	ALL	1,174
ANTI SHORT CYCLE TIMER	ASC	ALL	694
CURRENT SENSING RELAY (Run proof)	CSR	All	769
COMPRESSOR UNLOADERS (Suction pressure control. Medium Temp reciprocating compressors only. 1 Step for 3D and larger compressors.)	UNL-1	When Available	2,158

See Page 24 for defrost component prices

Mechanical options			
SUCTION LINE FILTER (Sealed)	SK-5	3 - 8	\$506
	SK-6	9 - 10	858
	SK-7	12 - 22	1,369
REPLACEABLE CORE SUCTION FILTER (With Bypass)	RSK-5	3 - 8	1,138
	RSK-6	9 - 10	1,456
	RSK-7	12 - 22	2,053
REPLACEABLE CORE LIQUID FILTER (With Bypass)	RLK-5	3 - 8	1,194
	RLK-6	9 - 10	1,490
	RLK-7	12 - 22	2,156
SUCTION LINE ACCUMULATOR (Must add Suction line filter option.)	ASK-4	3 - 8	817
	ASK-5	9 - 10	1,201
	ASK-6	12 - 22	2,508
OIL SEPARATOR	OS-1	3 - 6	1,391
	OS-2	7 - 10	1,481
	OS-3	12 - 22	1,741
OVERSIZED RECEIVERS	OSR-1	1 FAN	1,228
	OSR-2	2 FAN	688
	OSR-3	2 FAN TALL	695
PRESSURE RELIEF VALVE (For models built on FD1 cabinet base. Requires Oversized Receiver OSR-1 option)	RV	FD1 Cabinet	311
HEATED AND INSULATED RECEIVER (Temperature controlled with low pressure bypass timer)	HIR	ALL	808
CRANKCASE PRESSURE REGULATOR (Do not use with MOP style TXV's. Must provide refrigerant type, holding temperature, suction temperature, and maximum design capacity.)	CPR VALVE	3 - 5	1,601
		6 - 9	1,775
		10 - 15	3,306
		22	5,175
LIQUID INJECTION / DEMAND COOLING™ PRICE DEDUCT - to optionally remove the feature from low temperature models (not available for Scroll™ compressors)	LNJ-deduct	ALL	2,619
HAIL / SNOW GUARDS (Shipped loose to prevent shipping damage. Requires field installation)	SG-E	1 FAN	971
	SG-F	2 FAN	1,328
	SG-G	2 FAN TALL	1,487
2 UNIT STACKING RACK (Shipped empty. Condensing units must be field installed.)	SR-2	1 or 2 FAN	C/A
3 UNIT STACKING RACK (Shipped empty. Condensing units must be field installed.)	SR-3	1 or 2 FAN	C/A

C/A = Contact Application Engineering for a special quote on options not found in the price list.

† Phase Loss monitor is a standard feature for K5 Scroll Series CoreSense modules. Extended Range models

*OS8E4S thru OS15E4s and Low Temp OS10L4L thru *OS15L4S use K5 Series Scroll compressors.

QV-SERIES AIR COOLED CONDENSING UNITS

15 THRU 100 H.P.



Standard Features (all models)

- Copeland Discus compressor
- Available in single, dual or parallel compressor configurations
- Prepaint gray exterior/ G60 galvanized steel outdoor cabinet construction
- Heavy gauge G90 galvanized steel frame
- Award-winning floating coil design with generously sized condensers for energy savings
- Integral subcooling circuit boosts energy efficiency
- Mechanically formed pre-bent tubing reduces potential leaks
- Compatible with multiple refrigerants
- Optimized for high glide refrigerants
- Separate power and control electrical panels
- Swept wing fan/Venturi improves airflow and sound
- Hinged and removable access panels
- Flip top hinged Venturi panels for easy servicing
- Floored compressor cabinet with removable compressor tray
- Color-coded control wiring diagram with diagnostic terminals/ color-coded high and low pressure hoses
- LED control and compressor panel lighting
- 110V service convenience outlet
- Service gauge hooks
- 3 Phase condenser fan motors
- Electronic oil failure control
- Horizontal receiver
- Receiver isolation valves
- Refrigerant relief valve
- Replaceable core liquid line filter
- Suction line and discharge line vibrasorbers
- Liquid line isolation valve with sight glass
- Single point alarm with liquid line solenoid lockout
- Control circuit and condenser fan fusing
- Condenser fan contactors
- UL and cUL listed for outdoor use

Flooded (RF) Models include an adjustable head pressure control valve

Non-Flooded (RB) Models include electronic fan cycling control and a minimum charge monitor

Parallel Compressor Models (RF*P/ RB*P) include an oil management system

Options

- EC fan motors for variable speed
- Air defrost timer or electric defrost components
- Electric defrost kits available for up to 4 evaporators
- Oversized receiver
- ElectroFin[®], polyester coated fins or Bronz-Glow coil coating
- Liquid injection on low temp. compressors
- Heated and insulated receiver
- Oil separator with check valve
- Fan cycling control (RF models)
- Suction accumulator
- Liquid filter isolation valve
- Suction isolation valve
- Suction filter isolation valve
- Replaceable core suction filter
- Crankcase pressure regulator
- Hot gas bypass (Discharge tee, regulator or ball valve)
- Heat reclaim (Sporlan 3 way valve)
- Thru-the-door non-fused disconnect switch
- Thru-the-door fused disconnect (200 amp Max)
- Thru-the-door breaker disconnect (200 amp Max)
- Phase loss monitor
- Anti short cycle timer

QV-SERIES AIR COOLED CONDENSING UNITS

MODEL NUMBER NOMENCLATURE

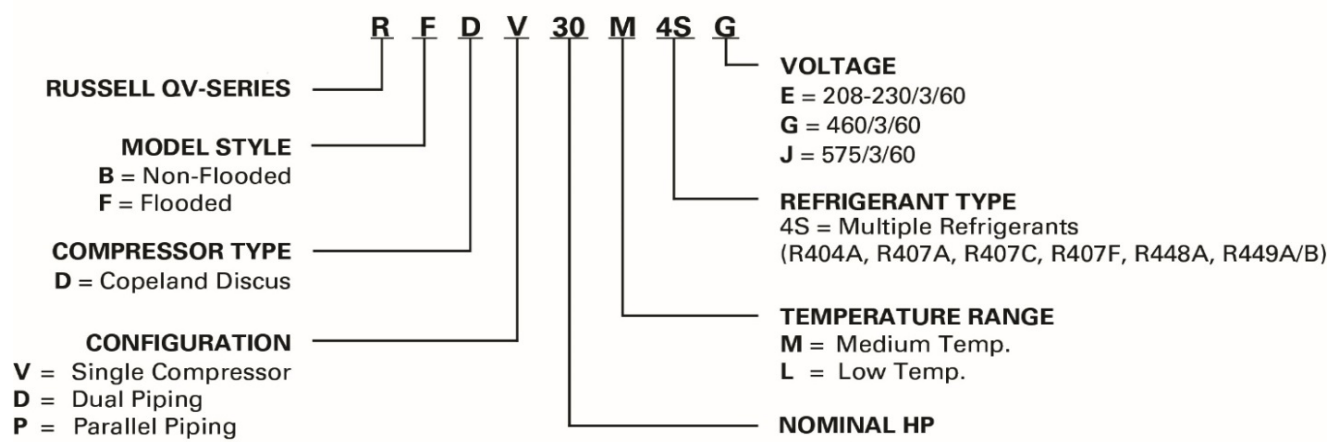

NOMINAL COMPRESSOR HP		
SINGLE COMP.	DUAL PIPING	PARALLEL PIPING
15 HP	30 (2) 15 HP	-
20 HP	40 (2) 20 HP	-
22 HP	44 (2) 22 HP	44 (2) 22 HP
25 HP	50 (2) 25 HP	50 (2) 25 HP
27 HP	54 (2) 27 HP	54 (2) 27 HP
30 HP	60 (2) 30 HP	60 (2) 30 HP
35 HP	70 (2) 35 HP	70 (2) 35 HP
40 HP	80 (2) 40 HP	80 (2) 40 HP
50 HP	100 (2) 50 HP	100 (2) 50 HP

QV-SERIES • SINGLE DISCUS COMPRESSOR MODELS

TEMP. RANGE	NOM H.P.	MODEL NUMBER	COMPRESSOR NUMBER (1 Compressor)	FLOODED MODELS (RF)			NON-FLOODED MODELS (RB)			4 Year Compressor Protection Plan (NET PRICE)
				208-230V/3	460V/3	575V/3	208-230V/3	460V/3	575V/3	
Medium Temp.	15	R*DV015M4S	3DS3R17ME	\$43,610	\$44,324	\$45,393	\$43,346	\$44,084	\$44,887	\$1,161
	20	R*DV020M4S	4DBNR20ME	48,267	48,948	49,811	47,241	48,207	49,288	1,437
	25	R*DV025M4S	4DHNR22ME	57,637	58,269	59,468	56,466	57,442	58,516	1,606
	30	R*DV030M4S	4DJNR28ME	67,368	68,102	69,576	63,719	64,509	65,618	1,722
	35	R*DV035M4S	6DHNR35ME	76,298	76,734	78,511	73,482	73,683	75,244	1,814
	40	R*DV040M4S	6DJNR40ME ¹	83,964	85,130	86,516	80,722	81,905	83,636	1,894
Low Temp.	50	R*DV050M4S	6DUNR49ME	N/A	101,630	N/A	N/A	96,517	N/A	2,143
	22	R*DV022L4S	4DJNF76KE	54,218	55,359	56,505	54,210	54,895	56,100	1,437
	27	R*DV027L4S	6DHNF93KE	62,760	63,261	64,358	61,545	62,655	63,410	1,606
	30	R*DV030L4S	6DJNF11ME	69,339	69,978	71,407	67,910	69,046	70,548	1,722
	40	R*DV040L4S	6DUNF13ME	N/A	87,133	N/A	N/A	85,710	N/A	2,073

QV-SERIES • DUAL DISCUS COMPRESSOR MODELS

TEMP. RANGE	NOM H.P.	MODEL NUMBER	COMPRESSOR NUMBER (2 Compressor)	FLOODED MODELS (RF)			NON-FLOODED MODELS (RB)			4 Year Compressor Protection Plan (NET PRICE)
				208-230V/3	460V/3	575V/3	208-230V/3	460V/3	575V/3	
Medium Temp.	30	R*DD030M4S	3DS3R17ME	\$87,221	\$88,648	\$90,786	\$86,692	\$88,167	\$89,775	\$2,321
	40	R*DD040M4S	4DBNR20ME	96,535	97,895	99,622	94,482	96,414	98,575	2,875
	50	R*DD050M4S	4DHNR22ME	115,274	116,538	118,936	112,932	114,885	117,031	3,212
	60	R*DD060M4S	4DJNR28ME	134,736	136,205	139,152	127,437	129,018	131,236	3,444
	70	R*DD070M4S	6DHNR35ME	152,595	153,469	157,021	146,964	147,366	150,488	3,628
	80	R*DD080M4S	6DJNR40ME ¹	167,929	170,260	173,031	161,443	163,810	167,272	3,788
Low Temp.	100	R*DD100M4S	6DUNR49ME	N/A	203,260	N/A	N/A	193,034	N/A	4,287
	44	R*DD044L4S	4DJNF76KE	108,437	110,718	113,011	108,420	109,791	112,199	2,875
	54	R*DD054L4S	6DHNF93KE	125,520	126,522	128,717	123,090	125,310	126,820	3,212
	60	R*DD060L4S	6DJNF11ME	138,678	139,957	142,815	135,820	138,091	141,097	3,444
	80	R*DD080L4S	6DUNF13ME	N/A	174,267	N/A	N/A	171,419	N/A	4,145

QV-SERIES • PARALLEL PIPED DISCUS COMPRESSOR MODELS

TEMP. RANGE	NOM H.P.	MODEL NUMBER	COMPRESSOR NUMBER (2 Compressor)	FLOODED MODELS (RF)			NON-FLOODED MODELS (RB)			4 Year Compressor Protection Plan (NET PRICE)
				208-230V/3	460V/3	575V/3	208-230V/3	460V/3	575V/3	
Medium Temp.	50	R*DP050M4S	4DHNR22ME	\$129,531	\$130,640	\$133,252	\$126,845	\$128,759	\$131,083	\$3,212
	60	R*DP060M4S	4DJNR28ME	147,787	149,130	152,113	139,323	140,823	142,938	3,444
	70	R*DP070M4S	6DHNR35ME	166,164	166,911	170,249	159,798	159,999	162,858	3,628
	80	R*DP080M4S	6DJNR40ME ¹	180,228	183,037	186,697	172,988	175,830	180,268	3,788
	100	R*DP100M4S	6DUNR49ME	N/A	225,618	N/A	N/A	213,667	N/A	4,287
Low Temp.	44	R*DP044L4S	4DJNF76KE	123,005	125,264	127,770	122,986	124,206	126,846	2,875
	54	R*DP054L4S	6DHNF93KE	139,151	139,978	142,777	136,404	138,624	140,642	3,212
	60	R*DP060L4S	6DJNF11ME	151,443	152,580	155,631	148,256	150,518	153,736	3,444
	80	R*DP080L4S	6DUNF13ME	N/A	193,436	N/A	N/A	190,222	N/A	4,145

¹6DJ3R40ME on 575/3

QV-SERIES AIR COOLED CONDENSING UNITS • OPTIONS AND ACCESSORIES

QV-SERIES • SINGLE COMPRESSOR MODEL OPTIONS

OPTION FAMILY	OPTION NAME	OPTION AVAILABLE ON MODELS:	LIST PRICE
Compressor Options	Compressor Unloading with Pressure Control for 1 Cycle Bank	020M-30M, 50M; 022L - 040L	\$2,162
	Compressor Unloading with Pressure Control for 2 Cycle Bank	035M & 045M	3,113
	Head Cooling Fan	All Models	1,790
	Liquid Injection	022L - 040L	3,930
Electrical and Control Panel Options	Air Defrost Time Clock	All Medium Temperature Models	576
	Anti-Short Cycle Timer	All Models	499
	Condenser Fan Breaker	015M -030M; 022L - 040L	754
	Condenser Fan Breaker	035M -050M	1,144
	Control Circuit Breaker	All Models	245
	EC Fan Motors with Electronic Variable Speed Control	015M -030M; 022L - 040L	Call Factory
	EC Fan Motors with Electronic Variable Speed Control	035M -050M	Call Factory
	Thru-the-door Fused Disconnect	Models with MOPD < 61A	1,523
	Thru-the-door Fused Disconnect	Models with 61A < MOPD < 101A	2,254
	Thru-the-door Fused Disconnect	Models with 101A < MOPD < 201A	3,862
	Thru-the-door Main Breaker	Models with MOPD ≤ 100A	1,946
	Thru-the-door Main Breaker	Models with 101A < MOPD < 201A	3,157
	Thru-the-door Non-Fused Disconnect	Models with MCA < 59A	1,371
	Thru-the-door Non-Fused Disconnect	Models with 59A < MCA > 99A	1,990
	Thru-the-door Non-Fused Disconnect	Models with 99A < MCA < 199A	3,291
	Phase-Loss Monitor - 250A	230V & 460V	962
	Phase-Loss Monitor - ICM450	230V	1,404
Phase-Loss Monitor - ICM450	460V	998	
Refrigeration Options	Crankcase Pressure Regulator Valves	015M	3,380
	Crankcase Pressure Regulator Valves	020M - 040M; 022L - 030L	4,257
	Crankcase Pressure Regulator Valves	050M & 040L	8,446
	Fan Cycling - Temperature or Pressure	All Flooded Models; Standard on Non-Flooded Models	1,518
	Heat Reclaim Valve	All Models	3,514
	Heated & Insulated Receiver	All Models	2,672
	Hot Gas Bypass Tee & Ball Valve	All Models	824
	Hot Gas Bypass Tee, Ball Valve & Regulator	All Models	4,776
	Liquid-line Filter Isolation Valve (Single Valve)	All Models	475
	Oil Separator with Check Valve	015 - 030	1,931
	Oil Separator with Check Valve	035 - 050	3,439
	Oil Separator with Check Valve & Oil Return Service Kit	015 - 030	3,625
	Oil Separator with Check Valve & Oil Return Service Kit	035 - 050	5,133
	Oversized Receiver	All Models	1,137
	Receiver Level Gauge	All Models	1,411
	Suction Accumulator - Standard	015	2,548
	Suction Accumulator - Standard	020-050	2,946
	Suction Accumulator - Heat Exchanger	015	3,157
	Suction Accumulator - Heat Exchanger	020-050	4,888
	Suction-line Filter - Replaceable Core	015M	1,112
	Suction-line Filter - Replaceable Core	020M - 040M; 022L - 030L	1,386
	Suction-line Filter - Replaceable Core	050M & 040L	1,440
	Suction-line Filter Isolation Valves	015M	780
	Suction-line Filter Isolation Valves	020M - 040M; 022L - 030L	1,255
	Suction-line Filter Isolation Valves	050M & 040L	2,184
	Suction-line Insulation	All Models	1,382

QV-SERIES AIR COOLED CONDENSING UNITS • OPTIONS AND ACCESSORIES

QV-SERIES • DUAL COMPRESSOR MODEL OPTIONS

OPTION FAMILY	OPTION NAME	OPTION AVAILABLE ON MODELS:	LIST PRICE
Compressor Options	Compressor Unloading with Pressure Control for 1 Cycle Bank	D040M - D060M, D100M; D044L - D080L	\$4,324
	Compressor Unloading with Pressure Control for 2 Cycle Bank	D070M & D080M	6,225
	Head Cooling Fan	All Models	3,580
	Liquid Injection	D044L - D080L	7,860
Electrical and Control Panel Options	Air Defrost Time Clock	All Medium Temperature Models	1,152
	Anti-Short Cycle Timer	All Models	998
	Condenser Fan Breaker	D030M -D060M; D044L - D080L	1,508
	Condenser Fan Breaker	D070M -D100M	2,288
	Control Circuit Breaker	All Models	245
	EC Fan Motors with Electronic Variable Speed Control	D030M -D060M; D044L - D080L	Call Factory
	EC Fan Motors with Electronic Variable Speed Control	D070M -D100M	Call Factory
	Thru-the-door Fused Disconnect	Models with MOPD < 61A	1,523
	Thru-the-door Fused Disconnect	Models with 61A < MOPD < 101A	2,254
	Thru-the-door Fused Disconnect	Models with 101A < MOPD < 201A	3,862
	Thru-the-door Main Breaker	Models with MOPD ≤ 100A	1,946
	Thru-the-door Main Breaker	Models with 101A < MOPD < 201A	3,157
	Thru-the-door Non-Fused Disconnect	Models with MCA < 59A	1,371
	Thru-the-door Non-Fused Disconnect	Models with 59A < MCA > 99A	1,990
	Thru-the-door Non-Fused Disconnect	Models with 99A < MCA < 199A	3,291
	Phase-Loss Monitor -250A	230V & 460V	962
Phase-Loss Monitor - ICM450	460V	1,997	
Refrigeration Options	Crankcase Pressure Regulator Valves	D030M	6,760
	Crankcase Pressure Regulator Valves	D040M - D080M; D044L - D060L	8,513
	Crankcase Pressure Regulator Valves	D100M & D080L	16,892
	Fan Cycling - Temperature or Pressure	All Flooded Models; Standard on Non-Flooded Models	3,037
	Heat Reclaim Valve	All Models	7,028
	Heated & Insulated Receiver	All Models	5,344
	Hot Gas Bypass Tee & Ball Valve	All Models	1,647
	Hot Gas Bypass Tee, Ball Valve & Regulator	All Models	9,551
	Liquid-line Filter Isolation Valve (Single Valve per Circuit)	All Models	951
	Oil Separator with Check Valve	D030 - D060	3,863
	Oil Separator with Check Valve	D070 - D100	6,879
	Oil Separator with Check Valve & Oil Return Service Kit	D030 - D060	7,251
	Oil Separator with Check Valve & Oil Return Service Kit	D070 - D100	10,267
	Oversized Receiver	All Models	2,273
	Receiver Level Gauge	All Models	2,823
	Suction Accumulator - Standard	D030	5,096
	Suction Accumulator - Standard	D040-D100	5,893
	Suction Accumulator - Heat Exchanger	D030	6,315
	Suction Accumulator - Heat Exchanger	D040-D100	9,776
	Suction-line Filter - Replaceable Core	D030M	2,224
	Suction-line Filter - Replaceable Core	D040M - D080M; D044L - D060L	2,773
	Suction-line Filter - Replaceable Core	D100M & D080L	2,881
	Suction-line Filter Isolation Valves	D030M	1,560
	Suction-line Filter Isolation Valves	D040M - D080M; D044L - D060L	2,511
	Suction-line Filter Isolation Valves	D100M & D080L	4,368
	Suction-line Insulation	All Models	2,764

QV-SERIES AIR COOLED CONDENSING UNITS • OPTIONS AND ACCESSORIES

QV-SERIES • PARALLEL COMPRESSOR MODEL OPTIONS

OPTION FAMILY	OPTION NAME	OPTION AVAILABLE ON MODELS:	LIST PRICE
Compressor Options	Compressor Unloading with Pressure Control for 1 Cycle Bank	P050M - P060M, P100M; P044L - P080L	\$4,324
	Compressor Unloading with Pressure Control for 2 Cycle Bank	P070M & P080M	6,225
	Head Cooling Fan	All Models	3,580
	Liquid Injection	P044L - P080L	7,860
Electrical and Control Panel Options	Air Defrost Time Clock	All Medium Temperature Models	576
	Anti-Short Cycle Timer	All Models	499
	Condenser Fan Breaker	P050M -P060M; P044L - P080L	754
	Condenser Fan Breaker	P070M -P100M	1,144
	Control Circuit Breaker	All Models	245
	EC Fan Motors with Electronic Variable Speed Control	P050M -P060M; P044L - P080L	Call Factory
	EC Fan Motors with Electronic Variable Speed Control	P070M -P100M	Call Factory
	Thru-the-door Fused Disconnect	Models with MOPD < 61A	1,523
	Thru-the-door Fused Disconnect	Models with 61A < MOPD < 101A	2,254
	Thru-the-door Fused Disconnect	Models with 101A < MOPD < 201A	3,862
	Thru-the-door Main Breaker	Models with MOPD ≤ 100A	1,946
	Thru-the-door Main Breaker	Models with 101A < MOPD < 201A	3,157
	Thru-the-door Non-Fused Disconnect	Models with MCA < 59A	1,371
	Thru-the-door Non-Fused Disconnect	Models with 59A < MCA > 99A	1,990
	Thru-the-door Non-Fused Disconnect	Models with 99A < MCA < 199A	3,291
	Phase-Loss Monitor - 250A	230V & 460V	962
Phase-Loss Monitor - ICM450	460V	1,997	
Refrigeration Options	Crankcase Pressure Regulator Valves	P050M-P60M	8,446
	Crankcase Pressure Regulator Valves	P070M-P100M; P044L - P080L	9,939
	Fan Cycling - Temperature or Pressure	All Flooded Models; Standard on Non-Flooded Models	2,122
	Heat Reclaim Valve	All Models	3,514
	Heated & Insulated Receiver	All Models	2,672
	Hot Gas Bypass Tee & Ball Valve	All Models	824
	Hot Gas Bypass Tee, Ball Valve & Regulator	All Models	4,776
	Liquid-line Filter Isolation Valve (Single Valve)	All Models	475
	Oversized Receiver	All Models	1,137
	Receiver Level Gauge	All Models	1,411
	Suction Accumulator - Standard	P050M-P60M	3,536
	Suction Accumulator - Standard	P070M-P100M; P044L - P080L	3,848
	Suction Accumulator - Heat Exchanger	P050M-P60M	4,888
	Suction Accumulator - Heat Exchanger	P070M-P100M; P044L - P080L	5,401
	Suction-line Filter - Replaceable Core	P050M-P60M	1,560
	Suction-line Filter - Replaceable Core	P070M-P100M; P044L - P080L	1,728
	Suction-line Filter Isolation Valves	P050M-P60M	2,184
	Suction-line Filter Isolation Valves	P070M-P100M; P044L - P080L	3,447
Suction-line Insulation	All Models	2,764	

QV-SERIES AIR COOLED CONDENSING UNITS • DEFROST KITS

ELECTRIC DEFROST KIT NOMENCLATURE

DL	A	24	-
Defrost Kit Large Condenser	Heater Contactor Quantity A: 1 Heater Contactor B: 2 Heater Contactor C: 3 Heater Contactor D: 4 Heater Contactor	Max Total Heater Amp Value	Special Kit Codes -1: 1 Evaporator with Multiple Heater Feeds -2: 2 Evaporators with Multiple Heater Feeds PP: Pressure Prop Kits for Large Evaporators

When selecting defrost kit, use the next higher amp value above the defrost load.
 All kits include 1 fan contactor and are suitable for 1 or 3 phase loads.
 Electrical resistance loads greater than 48 amps must be split into multiple circuits.

ELECTRIC DEFROST KIT OPTIONS • SINGLE AND PARALLEL COMPRESSOR MODELS

1 HEATER CONTACTOR		2 HEATER CONTACTORS		3 HEATER CONTACTORS		4 HEATER CONTACTORS	
Defrost Kit Model	List Price (\$US)	Defrost Kit Model	List Price (\$US)	Defrost Kit Model	List Price (\$US)	Defrost Kit Model	List Price (\$US)
DLA24 ¹	\$1,591						
DLA30 ¹	1,654						
DLA35 ¹	1,862	DLB35 ¹	\$2,376	DLC35	\$3,245		
DLA40 ¹	1,862	DLB40 ¹	2,376	DLC40	3,245		
DLA48 ¹	1,862	DLB48 ¹	2,376	DLC48	3,245		
		DLB60 ^{1 2 4}	2,470	DLC60 ¹	3,245	DLD60	\$3,838
		DLB96 ^{1 2 4}	2,990	DLC96 ¹	3,442	DLD96	3,869
				DLC144 ¹	4,690	DLD144 ^{3 5}	4,722
						DLD192 ^{3 5}	4,961

Defrost Kit selected for Single and Parallel compressor models is for entire unit. Up to 4 contactors.
¹Defrost Kit Available with Pressure Prop Kit for Large Evaporators (Special Kit Code: PP)
²Defrost Kit Available for Evaporator with Multiplie Heater Feeds (Special Kit Code: -1)
³Defrost Kit Available for 2 Evaporators with Multiplie Heater Feeds (Special Kit Code: -2)
⁴Defrost Kit Available for Evaporator with Multiplie Heater Feeds & Pressure Prop Kit (Special Kit Code: -1PP)
⁵Defrost Kit Available for 2 Evaporators with Multiplie Heater Feeds & Pressure Prop Kit (Special Kit Code: -2PP)

ELECTRIC DEFROST KIT OPTIONS • DUAL COMPRESSOR MODELS

1 HEATER CONTACTOR PER COMPRESSOR		2 HEATER CONTACTORS PER COMPRESSOR	
Defrost Kit Model	List Price (\$US)	Defrost Kit Model	List Price (\$US)
DLA24 ¹	\$3,182		
DLA30 ¹	3,307		
DLA35 ¹	3,723	DLB35 ¹	\$4,753
DLA40 ¹	3,723	DLB40 ¹	4,753
DLA48 ¹	3,723	DLB48 ¹	4,753
		DLB60 ^{1 2 3}	4,940
		DLB96 ^{1 2 3}	5,980

Defrost Kit selected is per compressor for Dual compressor models. Up to 2 contactors/compressor.
¹Defrost Kit Available with Pressure Prop Kit for Large Evaporators (Special Kit Code: PP)
²Defrost Kit Available for Evaporator with Multiplie Heater Feeds (Special Kit Code: -1)
³Defrost Kit Available for Evaporator with Multiplie Heater Feeds & Pressure Prop Kit (Special Kit Code: -1PP)

ELECTRIC DEFROST KIT OPTIONS • FUSEBLOCK AND CIRCUIT BREAKERS

MAX HEATER AMPS	1 HEATER CONTACTOR		2 HEATER CONTACTORS		3 HEATER CONTACTORS		4 HEATER CONTACTORS	
	Fuseblock List Price Adder	Circuit Breaker List Price Adder	Fuseblock List Price Adder	Circuit Breaker List Price Adder	Fuseblock List Price Adder	Circuit Breaker List Price Adder	Fuseblock List Price Adder	Circuit Breaker List Price Adder
24	\$111	\$839						
30	149	1,307						
35	149	1,307	\$149	\$1,551	\$223	\$1,664		
40	149	1,307	149	1,551	223	1,664		
48	149	1,307	149	1,551	223	1,664		
60			208	2,607	319	2,751	\$343	\$2,881
96			267	2,622	364	3,506	442	3,614
144					461	3,625	603	4,353
192							606	4,398

Dual Compressor Units require 2 Fuseblocks & 2 Circuit Breaker, 1 per compressor. Up to 2 contactors/compressor.

FAN CONTACTOR KIT OPTIONS • SINGLE AND PARALLEL COMPRESSOR MODELS

1 FAN CONTACTOR		
Kit Number	Max Motor Amps	List Price (\$US)
TMR-EF-15A	15	\$879
TMR-EF-30A	30	931

Kit Includes: Defrost Timer & Evaporator Fan Contactor

LEGACY V-SERIES DISCUS AIR COOLED CONDENSING UNITS

18 THRU 82 H.P.

Legacy V-Series models are discontinued.
Use QV-Series Air Cooled Condensing Units instead.



Model VCD Standard Features

- Copeland Discus Compressor with service valves
- Crankcase Heater
- Solid state compressor motor protection
- Compressor Head Cooling Fan (Low Temp models only)
- Oil Pressure Control
- Condenser Coil - Copper tubes, Aluminum fins, with subcooling circuit
- Condenser fan motors - 1140 RPM inherent 3 phase, with thermal overload protection with ball bearings
- Condenser fans - heavy duty, individually balance Aluminum fan blades
- Epoxy Coated Wire Fan Guards
- Receiver with inlet, and outlet shut-off valves, pressure relief valve
- Suction Line Components - filter (replaceable core on all parallel piped models)
- Liquid Line Components - sight glass/moisture indicator, liquid line drier replaceable core on all models
- Vibration Absorbers - suction and discharge line
- Control Panel with hinged access door
- High-Low Pressure Controls with flexible lines
- Fan Cycling Control, temperature actuated
- Compressor Contactor(s)
- Condenser Fan Contactors (as required)
- Control Circuit Branch Fusing
- Heavy galvanized steel frame and panels
- All Weather Housing, UL listed, cUL listed

Model VLD Standard Features

- All of the features included in the VCD package plus:
- Low Ambient Flooded Condenser Head Pressure Control

Model VSD Standard Features

- All of the features included in the VCD package plus:
- Energy Saving RUSS-SAVER Floating Head Pressure System
- Suction Line Pressure Stat (Low Temp. models only)

LEGACY V-SERIES CONDENSING UNIT NOMENCLATURE

Legacy V-Series models are discontinued.
Use QV-Series Air Cooled Condensing Units instead.

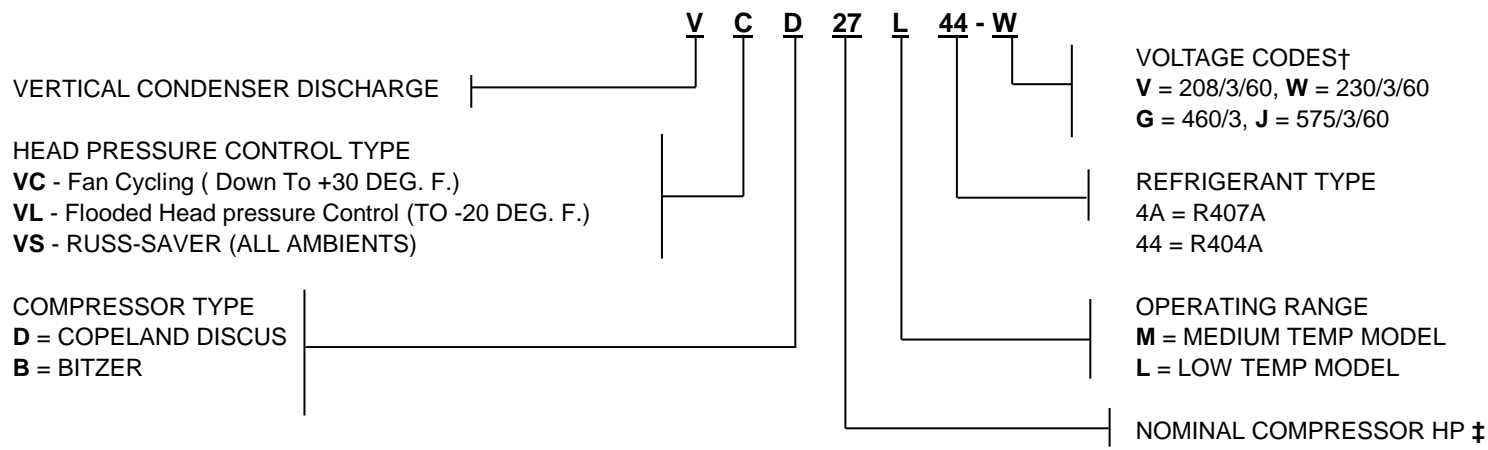

† VOLTAGE CODES

CODE	VOLTAGE
V	208/3/60
W	230/3/60
G	460/3
J	575/3/60

‡ COMPRESSOR CONFIGURATION

SINGLE	PARALLEL	DUAL
20HP	—	18 (2 - 7.5 HP)
25 HP	—	23 (2 - 10 HP)
N/A	24 (2 - 12 HP)	26 (2 - 12 HP)
27 HP	31 (2 - 15 HP)	32 (2 - 15 HP)
30 HP	41 (2 - 20 HP)	42 (2 - 20 HP)
35 HP	44 (2 - 22 HP)	46 (2 - 22 HP)
40 HP	51 (2 - 25 HP)	52 (2 - 25 HP)
50 HP	54 (2 - 27 HP)	56 (2 - 27 HP)
60 HP	61 (2 - 30 HP)	62 (2 - 30 HP)
N/A	71 (2 - 35 HP)	72 (2 - 35 HP)
N/A	81 (2 - 40 HP)	82 (2 - 40 HP)

LEGACY V-SERIES • SINGLE COMPRESSOR MODELS ‡

REF.	MODEL NUMBER	208-230/3/60V			460/3/60V			575/3/60V			4 Year Comp. Protection Plan
		VCD	VLD	VSD	VCD	VLD	VSD	VCD	VLD	VSD	
R407A or R404A	20M4*	V-Series models are no longer available. Use QV-Series models instead.									
	25M4*										
	30M4*										
	35M4*										
	40M4*										
R407A or R404A	27L4*	V-Series models are no longer available. Use QV-Series models instead.									
	30L4*										

LEGACY V-SERIES • DUAL COMPRESSOR MODELS ‡

REF.	MODEL NUMBER	208-230/3/60V			460/3/60V			575/3/60V			4 Year Comp. Protection Plan
		VCD	VLD	VSD	VCD	VLD	VSD	VCD	VLD	VSD	
R407A or R404A	18M4*	V-Series models are no longer available. Use QV-Series models instead.									
	23M4*										
	26M4*										
	32M4*										
	42M4*										
	52M4*										
	62M4*										
	72M4*										
82M4*											
R407A or R404A	46L4*	V-Series models are no longer available. Use QV-Series models instead.									
	56L4*										
	62L4*										

LEGACY V-SERIES • PARALLEL COMPRESSOR MODELS ‡

REF.	MODEL NUMBER	208-230/3/60V			460/3/60V			575/3/60V			4 Year Comp. Protection Plan
		VCD	VLD	VSD	VCD	VLD	VSD	VCD	VLD	VSD	
R407A or R404A	24M4*	V-Series models are no longer available. Use QV-Series models instead.									
	31M4*										
	41M4*										
	51M4*										
	61M4*										
	71M4*										
81M4*											
R407A or R404A	44L4*	V-Series models are no longer available. Use QV-Series models instead.									
	54L4*										
	61L4*										

LEGACY V-SERIES • OPTIONS AND ACCESSORIES

Legacy V-Series models are discontinued.
Use QV-Series Air Cooled Condensing Units instead.

SINGLE COMPRESSOR MODELS

MODEL NUMBER	SUCTION ACCUMULATOR	OIL SEPARATOR	LIQUID LINE SOLENOID (2)	CAPACITY CONTROL CYLINDER UNLOADING (3)	HOT GAS BYPASS CAPACITY CONTROL (5)	ANTI-SHORT CYCLE TIMER	THRU - DOOR NON - FUSED DISCONNECT SWITCH	
							208-230V	460V
20M4*	V-Series models are no longer available. Use QV-Series models instead.							
25M4*								
30M4*								
35M4*								
40M4*								

27L4*	V-Series models are no longer available. Use QV-Series models instead.							
30L4*								

PARALLEL COMPRESSOR MODELS

MODEL NUMBER	SUCTION ACCUMULATOR	OIL SEPARATOR	LIQUID LINE SOLENOID (2)	CYLINDER UNLOADING CAPACITY CONTROL (3)	HOT GAS BYPASS CAPACITY CONTROL (5)	ANTI-SHORT CYCLE TIMER	THRU - DOOR NON - FUSED DISCONNECT SWITCH	
							230 V	460 V
24M4*	V-Series models are no longer available. Use QV-Series models instead.							
31M4*								
41M4*								
51M4*								
61M4*								
71M4*								
81M4*								

44L4*	V-Series models are no longer available. Use QV-Series models instead.							
54L4*								
61L4*								

Condensing units are also available for use with R507, R134a or R407C. Contact factory for details.

Legacy V-Series Pricing Notes

- (1) Accessory prices for dual compressor models are for 1 set of the specified option per compressor system.
- (2) Liquid line solenoid valves and hot gas bypass options are shipped loose.
- (3) Capacity unloading is based on the maximum number of unloading steps available for each specific condensing unit. Some compressor models can offer fewer steps of unloading, contact factory for pricing. (See next page for an explanation.)
- (4) This option is typically applicable to high temperature applications and is not normally available low temp. applications.
- (5) HG bypass option contains a HG bypass control valve and solenoid valve. HG is injected into the distributor to help maintain a constant leaving air temp. Option shipped loose. Contact Application Engineering for other HG applications.

LEGACY V-SERIES OPTIONS AND ACCESSORIES • DUAL COMPRESSOR MODELS

Legacy V-Series models are discontinued.
Use QV-Series Air Cooled Condensing Units instead.

MODEL NUMBER	SUCTION ACCUMULATOR (1)	OIL SEPARATOR (1)	LIQUID LINE SOLENOID (2)	CAPACITY CONTROL CYLINDER UNLOADING (3)	HOT GAS BYPASS CAPACITY CONTROL (1,5)	ANTI-SHORT CYCLE TIMER	THRU - DOOR NON - FUSED DISCONNECT SWITCH		
							230V	460V	
18M4*	V-Series models are no longer available. Use QV-Series models instead.								
23M4*									
26M4*									
32M4*									
42M4*									
52M4*									
62M4*									
72M4*									
82M4*									
46L4*	V-Series models are no longer available. Use QV-Series models instead.								
56L4*									
62L4*									

LEGACY V-SERIES • ADDITIONAL OPTIONS AND ACCESSORIES		LIST PRICE EACH
DESCRIPTION		
ROOM THERMOSTAT		
AIR DEFROST TIMER		
ED KITS - DETAILED INFORMATION		
HOT GAS RE-EVAP DEFROST OPTION - No Longer Available		
MAIN CIRCUIT BREAKERS - (Per compressor system)	208V or 230V	10 THRU 15 HP
		20 THRU 35 HP
		40 THRU 60 HP
	460V	10 THRU 15 HP
		20 THRU 30 HP
		35 THRU 54 HP 60 HP
CURRENT SENSING RELAY (Price is based on one relay per unit. Double the price for Dual Compressor Models.)		
HEATED AND INSULATED RECEIVER	20 THRU 35 HP Single or Parallel Comp.	
	40 THRU 80 HP Single or Parallel Comp.	
	18 - 32 H.P. Dual Compressor	
	42-62 H.P. Dual Compressor 72-82 H.P. Dual Compressor	
HEATED AND INSULATED ACCUMULATOR (Must also add suction accumulator.)	20 THRU 35 HP Single or Parallel Comp.	
	40 THRU 80 HP Single or Parallel Comp.	
	18 - 23 H.P. Dual Compressor	
	42-62 H.P. Dual Compressor 72-82 H.P. Dual Compressor	
STAINLESS STEEL BRAIDED HOSES (Per compressor System)		
PRESSURE GAUGE KIT - HIGH, LOW, AND OIL PRESSURE GAUGES WITH VALVES - PER COMPRESSOR		
PHASE LOSS PROTECTION (Price is based on one monitor per unit. Double the price for Dual Compressor Models.)		
STAGED START RELAY FOR DUAL COMPRESSOR		
REPLACEABLE CORE SUCTION FILTER - Note: Replaceable core suction filters are standard for all parallel compressor units. See table at the right for all other models. Dual compressor systems include two suction filters (1 per system).	20 THRU 40 HP Single Compressor	
	18 - 32 H.P. Dual Compressor	
	42-62 H.P. Dual Compressor	
	72-82 H.P. Dual Compressor	
Sub Circuit Fuses (Fuse blocks already included with ED kit) (This price in addition to ED-Kit adder)	For 1 evaporator Electric Defrost Kit (price per kit)	
	For 2 evaporators Electric Defrost Kit (price per kit)	
	For 3 evaporators Electric Defrost Kit (price per kit)	
CRANKCASE PRESSURE REGULATING VALVE - MTD	20 - 41 H.P. Single or Parallel Compressor	
	44 - 61 H.P. Single or Parallel Compressor	
	71 - 81 H.P. Single or Parallel Compressor	
	18 - 26 HP Dual Compressor	
	32-42 H.P. Dual Compressor	
	46-82 H.P. Dual Compressor	

V-Series models are no longer available. Use QV-Series models instead.

**** Models are available for R404A, R507, R407A, R407C. Contact Applications Engineering to request a special quote.**

- (1) Accessory prices for dual compressor models are for 1 set of the specified option per compressor system.
- (2) Liquid line solenoid valves and hot gas bypass options are shipped loose.
- (3) Capacity unloading is based on the maximum number of unloading steps available for each specific condensing unit. Some compressor models can offer fewer steps of unloading, contact factory for special pricing.

See notes below for an explanation of unloader codes.

UNL-1 = 1 bank of unloading, 1 compressor per condensing unit.
UNL-2 (1) = 2 banks of unloading, 1 compressor per condensing unit.
UNL-2 (2) = 2 compressors per unit, 1 bank per compressor (2 total).
UNL-2 (4) = 2 compressors per unit, 2 banks per compressor (4 total).

- (4) This option is typically applicable to high temperature applications and is not normally available for low temp. units.
- (5) HG bypass option contains a HG bypass control valve and solenoid valve. HG is injected into the distributor to help maintain a constant leaving air temp. Option shipped loose. Contact the factory for other HG applications.

C/F = Contact Application Engineering to request a custom quote.

ELECTRIC DEFROST COMPONENTS

(See Page 24 for Next-Gen II and page 31 for QV-Series defrost kits)

The Russell **Electric Defrost System** provides unique features that other defrost systems lack. These energy saving features are as follows:

- The auxiliary switch on 3 phase systems and block-out relays on 1 phase systems prevents the defrost heaters from energizing when the compressor is in operation. This features holds the maximum amp draw to the largest single load that the system will draw, and therefore reduces the electrical service requirement to the condensing unit.
- On multiple evaporator systems, individual defrost contactors are used in conjunction with sequencing relays* to allow each evaporator to terminate defrost independently. This efficient method of defrost saves electricity, and reduces the potential of overheating and steaming the evaporators. In addition, the amount of heat added to the room is kept to a minimum, reducing the run time of the condensing unit.

KIT NUMBER	TIMER	AUXILIARY SWITCH	BLOCK-OUT RELAY	† DEFROST HEATER CONTACTOR (1)	‡ FAN CONTACTOR	SEQUENCING RELAY
ED-5	1	—	1-15A	—	—	—
ED-6	1	—	1-20A	—	—	—
ED-7	1	—	1-25A	—	—	—
ED-10	1	—	1-30A	—	—	—
ED-210	1	—	1-30A	—	—	—
ED-11	1	1	—	1-30A	—	—
ED-211	1	1	—	1-30A	—	—
ED-12	1	1	—	1-30A	1-25A	—
ED-13	1	1	—	1-50A	—	—
ED-213	1	1	—	1-50A	—	—
ED-14	1	1	—	1-50A	1-25A	—
ED-15	1	1	—	2-75A	—	—
ED-16	1	1	—	2-75A	1-25A	—
ED-17	1	1	—	1-15A	1-25A	—
ED-18	1	1	—	1-20A	1-20A	—
ED-20	1	—	1-30A	—	—	2
ED-21	1	1	—	2-15A	—	2
ED-22	1	1	—	2-15A	1-25A	2
ED-23	1	1	—	2-25A	—	2
ED-24	1	1	—	2-25A	1-25A	2
ED-25	1	1	—	2-50A	—	2
ED-26	1	1	—	2-50A	1-25A	2
ED-27	1	1	—	2-75A	—	2
ED-28	1	1	—	2-75A	1-25A	2
ED-30	1	—	1-30A	—	—	3
ED-31	1	1	—	3-10A	—	3
ED-32	1	1	—	3-10A	1-25A	3
ED-33	1	1	—	3-15A	—	3
ED-34	1	1	—	3-15A	1-25A	3
ED-35	1	1	—	3-30A	—	3
ED-36	1	1	—	3-30A	1-25A	3
ED-37	1	1	—	3-75A	—	3
ED-38	1	1	—	3-75A	1-40A	3

* Except for ED-210, ED-211, ED-213

† Heater contactor amperage is based on its resistive rating.

‡ Fan motor contactor amperage is based on its inductive rating.

TIMER
Initiates the defrost cycle. Also used as over ride protection for defrost termination.

AUXILIARY SWITCH
Mounted on the compressor contactor, it prevents the defrost contactor from operating whenever the compressor is energized.

BLOCK-OUT RELAY
Serves the same function as auxiliary switch, except used when defrost contactor is not required (single phase only).

FAN CONTACTOR
Used with 460V motors or when 230V motors are wired for 3 phase power.

DEFROST CONTACTOR
Carries amperage load for heaters. Contactor selection is based on the maximum resistive load rating of the contactor.

SEQUENCING RELAYS
Provides interconnection of multiple unit coolers on a single system so that each unit cooler is allowed to individually terminate defrost on temperature.

ELECTRIC DEFROST KIT NOMENCLATURE (See Page 24 for Next-Gen II and page 31 for QV-Series defrost kits)

E D 1 2 - A 2 - F B

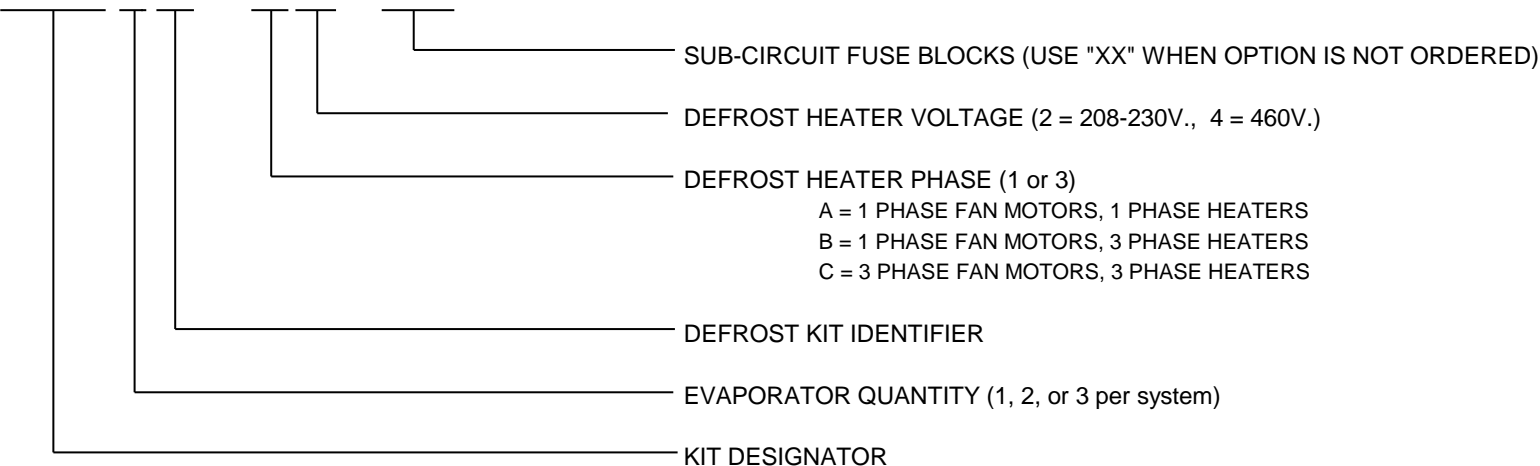

ELECTRIC DEFROST PROVISIONS

(See Page 24 for Next-Gen II and page 31 for QV-Series defrost kits)

QTY OF UNIT COOLERS	DESCRIPTION	† DEFROST KIT NUMBER				LIST PRICE	
		1 PH. FANS 1 PH. HTRS	1 PH. FANS 3 PH. HTRS	230 V. 3 PH. FANS 3 PH. HTRS	460 V. 3 PH. FANS 3 PH. HTRS	MOUNTED ††	‡ SUB-CIRC. FUSE BLOCKS (LESS FUSES)

DEFROST KITS WHEN THE EVAPORATOR FAN MOTORS ARE WIRED FOR 230/1.

ONE UNIT COOLER PER SYSTEM	Up to 15 Amps Heater (w/ relay)	ED5-A2-XX	N/A	N/A	N/A	\$695	N/A
	20 Amps Heater (w/ relay)	ED6-A2-XX	N/A	N/A	N/A	695	N/A
	25 Amps Heater (w/ relay)	ED7-A2-XX	N/A	N/A	N/A	695	N/A
	Up to 30 Amps Heater (w/ relay)	ED10-A2-XX	N/A	N/A	N/A	695	N/A
	30 Amps - Heater (w/ contactors)	N/A	ED11-B2-XX	N/A	N/A	695	\$174
	50 Amps - Heater	ED13-A2-XX	ED13-B2-XX	N/A	N/A	1,348	174
	75 Amps Heater	ED15-A2-XX	ED15-B2-XX	N/A	N/A	2,066	203
TWO UNIT COOLERS PER SYSTEM	Up to 30 Amps Heater (w/ relay)	ED210-A2-XX	N/A	N/A	N/A	695	N/A
	30 Amps Heater	ED211-A2-XX	ED211-B2-XX	N/A	N/A	695	174
	50 Amps Heater	ED213-A2-XX	ED213-B2-XX	N/A	N/A	1,348	211
	Up to 15 Amps Heaters each (w/ relays)	ED20-A2-XX	N/A	N/A	N/A	1,925	N/A
	15 Amps Heaters each	ED21-A2-XX	ED21-B2-XX	N/A	N/A	1,925	312
	25 Amps Heaters each (w/ relays)	ED23-A2-XX	N/A	N/A	N/A	1,977	312
	25 Amps Heaters each (w/ contactors)	N/A	ED23-B2-XX	N/A	N/A	1,977	312
	50 Amps Heaters each	ED25-A2-XX	ED25-B2-XX	N/A	N/A	2,217	312
	75 Amps Heaters each	ED27-A2-XX	ED27-B2-XX	N/A	N/A	3,019	406
THREE UNIT COOLERS PER SYSTEM	Up to 10 Amps Heaters each (w/ relays)	ED30-A2-XX	N/A	N/A	N/A	2,620	N/A
	16 Amps Heaters each (w/ relays)	ED31-A2-XX	N/A	N/A	N/A	2,620	385
	16 Amps Heaters each (w/ relays)	ED33-A2-XX	N/A	N/A	N/A	2,620	385
	16 Amps Heaters each (w/ contactors)	N/A	ED33-B2-XX	N/A	N/A	2,620	385
	30 Amps Heaters each (w/ relays)	ED35-A2-XX	N/A	N/A	N/A	2,940	385
	30 Amps Heaters each (w/ contactors)	N/A	ED35-B2-XX	N/A	N/A	2,940	385
	50 Amps Heaters each	ED37-A2-XX	ED37-B2-XX	N/A	N/A	3,342	457

DEFROST KITS WHEN THE EVAPORATOR FAN MOTORS ARE WIRED FOR 230/3, 460/3, OR 460/1.

ONE UNIT COOLER	Up to 25 Amps Heater	ED17-A4-XX	N/A	N/A	N/A	\$1,405	\$288
	30 Amps Heater	ED12-A4-XX	ED12-BX-XX	ED12-C2-XX	ED12-C4-XX	1,405	288
	50 Amps Heater	N/A	ED14-BX-XX	ED14-C2-XX	ED14-C4-XX	1,643	288
	75 Amps Heater	N/A	N/A	ED16-C2-XX	ED16-C4-XX	2,260	336
TWO UNIT COOLERS	Up to 15 Amps Heaters per Unit Cooler	N/A	ED22-BX-XX	ED22-C2-XX	ED22-C4-XX	2,363	385
	25 Amps Heaters per Unit Cooler	N/A	ED24-BX-XX	ED24-C2-XX	ED24-C4-XX	2,363	385
	50 Amps Heaters per Unit Cooler	N/A	ED26-BX-XX	ED26-C2-XX	ED26-C4-XX	2,491	440
	75 Amps Heaters per Unit Cooler	N/A	N/A	ED28-C2-XX	N/A	3,216	535
THREE UNIT COOLERS	Up to 10 Amps Heaters per Unit Cooler	N/A	ED32-BX-XX	ED32-C2-XX	ED32-C4-XX	3,016	511
	16 Amps Heaters per Unit Cooler	N/A	ED34-BX-XX	ED34-C2-XX	ED34-C4-XX	3,016	511
	30 Amps Heaters per Unit Cooler	N/A	ED36-BX-XX	ED36-C2-XX	ED36-C4-XX	3,729	511
	50 Amps Heaters per Unit Cooler	N/A	ED38-BX-XX	ED38-C2-XX	ED38-C4-XX	4,142	612

† Replace "XX" with "FB" when ordering the sub-circuit fuse block option. For description of "ED" kit nomenclature see page 36.

‡ Sub-circuit fuse block price includes fuse blocks installed in the condensing unit, **less fuses**, for evaporator(s) motors and defrost heaters.

Sub-circuit fusing option is not available for 1/2 to 6 HP Minicon models due to space limitations in the control panel.

* Add "FB" suffix to ED kit part number when pricing sub-circuit fuse block option.

†† ED-Kits are supplied as mounted components and not available as a "ship loose" accessory.

NEXT-GEN WC-SERIES™ • INDOOR WATER COOLED CONDENSING UNITS

1/2 THRU 6 H.P.

Standard Features (all models)

- Hermetic or Scroll compressors
- Galvanized steel base
- High efficiency water cooled coaxial condenser and heat exchange
- Mechanically formed pre-bent tubing for reduced leak potential
- **Liquid line kit with filter/drier and sight glass with moisture indicator**
- Suction line piping (filter optional)
- Suction and discharge service valves (as required)
- Base mounted shut-off valves
- Color-coded point-to-point wiring
- Large electrical control panel with hinged/removable door
- Refrigerant receiver with isolation valve and pressure relief plug
- Adjustable high and low pressure controls
- Control transformer (460V to 230V) as required
- Compressor contactor (1Ø or 3Ø), start kit (1Ø)
- Crankcase heater
- **Electronic defrost timer with defrost contactor/ relay on low temp. models (2 evaps. Maximum)**
- **Electronic air defrost timer (Medium temperature models)**

For defrost provisions see pages 36 & 37

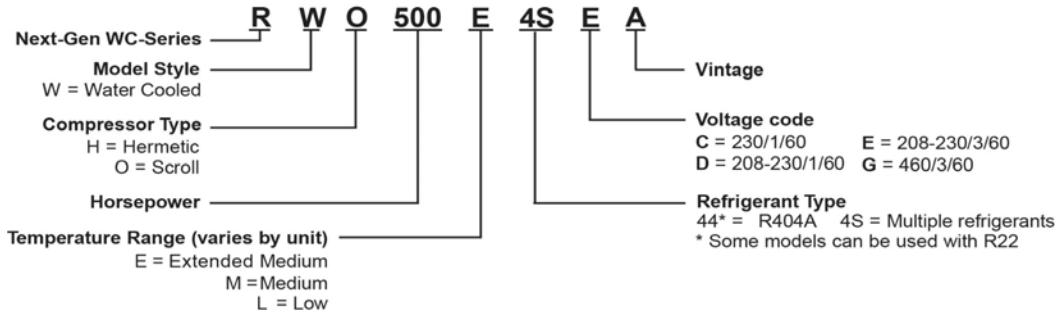
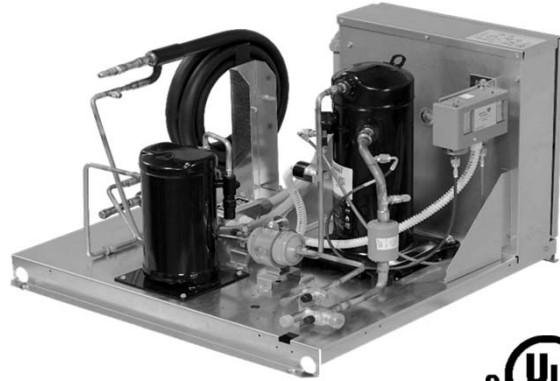

NEXT-GEN WC-SERIES • HERMETIC COMPRESSOR MODELS

Temp Range	NOM H.P.	Model Number	Compressor	BASE LIST PRICE (Includes Liquid Line Kit with Filter/Drier and Sight Glass with Moisture Indicator, and Defrost Timer or Kit)			Water Reg. Valve‡	Sealed Suction Line Filter	Suction Accum. ^	Pump Down Switch	4 Year Comp. Protection Plan	Approx. Ship Wt. (LBS)
				208-230V/3	208-230V/1	460V/3						
Medium Temp	1/2	RWH055E4S	RST45C1E	N/A	\$4,592	N/A	\$451	\$344	\$529	\$337	\$109 NET	152
	1/2	RWH080E4S	RST55C1E	N/A	4,687	N/A	451	344	529	337	109 NET	156
	3/4	RWH090E4S	RST64C1E	N/A	4,827	N/A	451	344	529	337	109 NET	160
	3/4	RWH100E4S	RST70C1E	\$5,391	5,214	N/A	451	344	529	337	109 NET	167
	1	RWH125E4S	RST97C1E	5,544	5,588	N/A	451	344	529	337	123 NET	195
	1-1/2	RWH150E44	CS10K6E	5,700	5,434	6,359	451	344	529	337	123 NET	205
	2	RWH200E44	CS12K6E	6,518	6,000	N/A	451	344	529	337	134 NET	228
	2-1/2	RWH250E44	CS14K6E	6,906	6,440	7,335	489	344	529	337	134 NET	235
Low Temp	3	RWH300E44	CS18K6E	7,893	7,620	8,205	489	409	817	337	148 NET	253
	3	RWH325E44	CS20K6E	8,285	7,986	8,557	489	409	817	337	148 NET	273
	1-1/2	RWH150L44	CF06K6E	5,609	5,463	N/A	451	344	529	337	123 NET	195
	2	RWH200L44	CF09K6E	5,819	5,674	6,276	451	344	529	337	134 NET	243
	3	RWH300L44	CF12K6E	8,247	8,053	8,381	489	409	817	337	148 NET	255

ADDITIONAL OPTIONS FOR NEXT-GEN WC-SERIES UNITS

DESCRIPTION	LIST PRICE
ANTI-SHORT CYCLE TIMER	\$694
GAUGE KIT, HIGH, LOW, AND OIL PRESSURE	1,941
PHASE LOSS MONITOR	1,175
CUPRONICKEL HEAT EXCHANGER AND WATER PIPING	CF
ELECTRONIC OIL PRESSURE CONTROL (SOPC)	847
TWO-TIERED STACKING RACK	CF

^ For pre-piped Suction Accumulator, the Sealed Suction Line Filter option must also be ordered.

CF = Contact Factory for pricing

‡ OPTIONAL FIELD INSTALLED WATER REGULATING VALVE (ALL MODELS) SHIPPED LOOSE

The V46 pressure-actuated water-regulating valve size estimates are based on 65°F coil inlet water temperature and the refrigerant pressure at 105°F saturated condensing. An adjustable water-pressure reducing valve (0 to 50 psi) is required upstream from the V46 valve, to reduce the inlet water pressure and achieve the required flowrates. Refer to the V46 Pressure-Actuated Water-Regulating Valve Product Bulletin, LIT-125687 on the Johnson Control QuickLIT website for complete information on sizing and adjusting V46 valves.

Water Flowrates (GPM)	Water Regulating Valve
1.5 to 11.5	V46AA-1C
11.5 to 21	V46AB-1C

NEXT-GEN WC-SERIES™ • INDOOR WATER COOLED CONDENSING UNITS

1/2 THRU 6 H.P.

NEXT-GEN WC-SERIES • SCROLL COMPRESSOR MODELS

Temp Range	NOM H.P.	Model Number	Compressor	BASE LIST PRICE (Includes Liquid Line Kit with Filter/Drier and Sight Glass with Moisture Indicator, and Defrost Timer or Kit)*			Water Reg. Valve‡	Sealed Suction Line Filter	Suction Accum.^	Pump Down Switch	4 Year Comp. Protection Plan	Approx. Ship Wt. (LBS)
				208-230V/3	208-230V/1	460V/3						
Medium Temp	1/2	RWO060M4S	ZB06KAE	\$8,687	\$8,675	N/A	\$451	\$344	\$529	\$337	\$202 NET	195
	1/2	RWO080M4S	ZB07KAE	8,790	8,760	N/A	451	344	529	337	202 NET	195
	1	RWO100M4S	ZB08KAE	8,904	8,846	N/A	451	344	529	337	202 NET	195
	1-1/3	RWO130E4S	ZS09KAE	9,034	8,944	\$9,364	451	344	529	337	202 NET	195
	1-1/2	RWO150E4S	ZS11KAE	9,659	9,568	9,989	451	344	529	337	202 NET	205
	1-3/4	RWO180E4S	ZS13KAE	9,886	9,795	10,216	451	344	529	337	202 NET	210
	2	RWO200E4S	ZS15KAE	10,056	9,966	10,386	451	344	529	337	202 NET	215
	2-1/2	RWO250E4S	ZS19KAE	10,191	10,080	10,583	489	344	529	337	202 NET	230
	3	RWO300E4S	ZS21KAE	10,364	10,233	10,818	489	409	817	337	263 NET	305
	3-1/2	RWO350E4S	ZS26KAE	11,012	10,873	11,335	489	409	817	337	263 NET	325
	4	RWO400E4S	ZS29KAE	11,375	11,219	11,687	549	409	817	337	275 NET	352
	4-1/2	RWO450E4S	ZS33KAE	11,233	11,075	11,641	549	409	817	337	282 NET	375
	6	RWO500E4S	ZS38K4E	11,790	11,631	12,294	849	409	817	337	282 NET	383
	6-1/2	RWO600E4S	ZS45K4E	13,610	N/A	13,828	849	409	817	337	282 NET	405
Low Temp	1	RWO100L4S	ZF03KAE	9,591	9,090	N/A	451	344	529	337	202 NET	230
	1-1/3	RWO130L4S	ZF04KAE	9,758	9,313	N/A	451	344	529	337	202 NET	230
	1-1/2	RWO160L4S	ZF05KAE	9,987	9,601	N/A	451	344	529	337	202 NET	230
	2	RWO230L4S	ZF07KAE	10,278	10,144	10,600	451	344	529	337	202 NET	230
	2-1/2	RWO250L4S	ZF08K4E	10,642	10,495	10,756	489	344	529	337	202 NET	240
	3	RWO300L4S	ZF09K4E	10,907	10,749	12,214	489	409	817	337	263 NET	245
	3-1/2	RWO350L4S	ZF11K4E	11,396	11,235	11,663	489	409	817	337	263 NET	255
	4	RWO400L4S	ZF13K4E	11,871	11,720	12,140	549	409	817	337	275 NET	352
5	RWO500L4S	ZF15K4E	12,017	11,871	12,297	849	409	817	337	275 NET	367	
6	RWO600L4S	ZF18K4E	13,548	N/A	14,285	849	409	817	337	282 NET	383	

ADDITIONAL OPTIONS FOR NEXT-GEN WC-SERIES UNITS

DESCRIPTION	LIST PRICE
ANTI-SHORT CYCLE TIMER	\$694
GAUGE KIT, HIGH, LOW, AND OIL PRESSURE	1,941
PHASE LOSS MONITOR	1,175
CUPRONICKEL HEAT EXCHANGER AND WATER PIPING	CF
ELECTRONIC OIL PRESSURE CONTROL (SOPC)	847
TWO-TIERED STACKING RACK	CF

* See page 38 for a complete list of features, voltage codes and an example of nomenclature layout.

^ For pre-piped Suction Accumulator, the Sealed Suction Line Filter option must also be ordered.

CF = Contact Factory for pricing

‡ OPTIONAL FIELD INSTALLED WATER REGULATING VALVE (ALL MODELS) SHIPPED LOOSE

The V46 pressure-actuated water-regulating valve size estimates are based on 65°F coil inlet water temperature and the refrigerant pressure at 105°F saturated condensing. An adjustable water-pressure reducing valve (0 to 50 psi) is required upstream from the V46 valve, to reduce the inlet water pressure and achieve the required flowrates. Refer to the V46 Pressure-Actuated Water-Regulating Valve Product Bulletin, LIT-125687 on the Johnson Control QuickLIT website for complete information on sizing and adjusting V46 valves.

Water Flowrates (GPM)	Water Regulating Valve
1.5 to 11.5	V46AA-1C
11.5 to 21	V46AB-1C

LEGACY RW SERIES • INDOOR WATER COOLED CONDENSING UNITS

1/2 THRU 5 H.P.

RW Series 1/2 to 5 H.P. Hermetic models are no longer available.

- Selection of Hermetic, Semi-Hermetic, and Discus Compressors
- Low Height, Compact Design on a Sturdy Base.
- High-Low Pressure Control, Compressor Contactor and Control Circuit Fusing.
- Liquid Receiver with Shut-off Valve and Pressure Relief Plug.
- Coaxial Condenser as standard, Cleanable Condenser is optional.

For defrost provisions see pages 30 & 31.



COMP TYPE	§ REF TYPE	NOM H.P.	MODEL NUMBER	BASE LIST PRICE			WATER REG. VALVE‡	CLEANABLE CONDENSER	LIQUID LINE KIT (LK)	* SUCTION LINE KIT (SK)	^ SUCTION ACCUM.	4 Year Comp. Protection Plan	Approx. Ship Wt (LBS)
				230/3	230/1	460/3							
HERMETIC	MED. TEMP R404A	0.5	RWH055M44	<p>RW Series 1/2 to 5 H.P. models are no longer available.</p> <p>Use Next-Gen WC-Series models instead.</p>									
		0.5	RWH080M44										
		0.75	RWH090M44										
		0.75	RWH100M44										
		1.0	RWH125M44										
		1.5	RWH151M44										
		1.5	RWH200M44										
		1.75	RWH251M44										
		2.0	RWH301M44										
		3.0	RWH325M44										
	4.0	RWH400M44											
	5.0	RWH500M44											
	LOW TEMP R404A	0.75	RWH075L44										
		1.0	RWH100L44										
		1.5	RWH165L44										
2.0		RWH215L44											
3.0		RWH315L44											
SEMI-HERMETIC	MED. TEMP R404A	0.75	RWS075M44										
		1.0	RWS100M44										
		1.5	RWS150M44										
		2.0	RWS200M44										
		2.5	RWS250M44										
	3.0	RWS300M44											
	LOW TEMP R404A	0.5	RWS050L44										
		0.75	RWS075L44										
		1.0	RWS100L44										
		1.5	RWS150L44										
2.0		RWS200L44											
3.0	†RWS300L44												

RW SERIES • INDOOR WATER COOLED CONDENSING UNITS

3 THRU 40 H.P.

STANDARD FEATURES:

- Copeland Discus (RWD model) Compressors.
- High Efficiency, Cleanable Shell and Tube Condenser/Receiver
- Compressor Contactor and Control Circuit Fusing in a NEMA 1 enclosure.
- Models up to 80 HP are available, Contact Factory for pricing.
- High / Low Pressure and Oil Pressure Controls.
- Spring Mounted Compressor.
- Head Cooling Fan (when required).
- Isolation and Pressure Relief Valves.
- UL and C-UL listed.

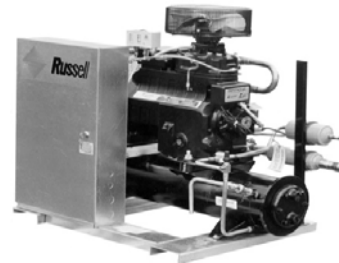

OPTIONAL FEATURES:

- Oversized Control Panel (OCP) required when adding defrost kits or other electrical components.
- Two tiered stacking racks.

Shown with optional oversized control panel, liquid line assembly, suction line assembly and Electronic oil pressure control.

REFR. TYPE	NOM HP	MODEL NUMBER	LIST PRICE		WATER REG. VALVE‡	LK	* SK	^ SUCTION LINE ACCUM.	OIL SEPARATOR	4 Year Comp. Protection Plan	APPROX. SHIP WT (LBS)	
			230/3	460/3								
MED. TEMP. R404A	3.0	RWS3M44	Model no longer available.									
	5.0	RWD5M44	\$19,276	\$21,338	\$849	\$631	\$506	\$817	\$1,391	\$580	NET	485
	5.0	RWD6M44	20,745	22,878	849	631	506	817	1,391	580	NET	495
	7.5	RWD7M44	22,208	24,544	1,163	631	506	817	1,481	580	NET	540
	7.5	RWD8M44	24,320	26,426	1,163	631	506	817	1,481	580	NET	590
	10.0	RWD10M44	28,580	29,548	1,163	849	858	1,201	1,481	750	NET	780
	12.0	RWD12M44	30,967	31,521	1,502	1,065	1,369	2,508	1,741	900	NET	790
	15.0	RWD15M44	31,912	32,864	1,502	1,065	1,369	2,508	1,741	1,129	NET	800
	20.0	RWD20M44	36,656	37,361	1,502	1,065	1,369	2,508	1,741	1,437	NET	835
	25.0	RWD25M44	42,307	42,896	1,502	1,244	1,369	3,141	2,885	1,616	NET	1,050
LOW TEMP. R404A	3.0	RWS3L44	Model no longer available.									
	3.0	RWD3L44	16,600	18,458	849	631	506	817	1,391	318	NET	390
	4.0	RWD4L44	17,792	19,587	849	631	506	817	1,391	472	NET	465
	5.0	RWD5L44	18,645	20,032	849	631	506	817	1,391	472	NET	485
	6.0	RWD6L44	20,919	22,068	849	631	506	817	1,391	572	NET	530
	8.0	RWD8L44	22,808	24,387	1,163	631	506	817	1,481	580	NET	590
	9.0	RWD9L44	25,241	26,977	1,163	849	858	1,201	1,481	750	NET	620
	10.0	RWD10L44	27,844	28,491	1,163	849	858	1,201	1,481	750	NET	795
	12.0	RWD12L44	30,923	31,296	1,163	1,065	1,369	2,508	1,741	900	NET	820
	15.0	RWD15L44	33,680	34,081	1,502	1,065	1,369	2,508	1,741	1,161	NET	845
22.0	RWD22L44	39,676	39,977	1,502	1,065	1,369	2,508	1,741	1,437	NET	1,030	
27.0	RWD27L44	55,775	56,160	1,502	1,244	1,369	3,141	2,885	1,616	NET	1,255	
30.0	RWD30L44	57,860	58,647	1,502	1,244	1,369	3,141	2,885	1,722	NET	1,310	

* Suction line assembly option must be ordered to receive the Suction Accumulator pre-piped.

^ For pre-piped Suction Accumulator, the SK option must also be ordered.

‡ Water Reg. Valve shipped Loose for field installation.

OPTIONAL PIPING COMPONENTS			
* LIQUID LINE KIT		* SUCTION LINE KIT	
HP	Kit Num	HP	Kit Num
3 - 8	LK-4	3 - 8	SK-4
9 - 10	LK-5	9 - 10	SK-5
12 - 22	LK-6	12 - 22	SK-6
25 - 40	LK-7	25 - 40	SK-7

See pages 21 & 25 for piping component pricing.

ADDITIONAL OPTIONS FOR RW UNITS	
DESCRIPTION	LIST PRICE
ANTI-SHORT CYCLE TIMER	\$694
GAUGE KIT, HIGH, LOW, AND OIL PRES.	1,941
PHASE LOSS MONITOR	1,175
OVERSIZED CONTROL PANEL (OCP)	663
ELECTRONIC OIL PRESSURE CONTROL (SOPC)	847
TWO-TIERED STACKING OPTION - RWH and RWS	C/F
TWO-TIERED STACKING OPTION - RWD	C/F

LEGACY RW / RN SERIES • SCROLL CONDENSING UNITS

RW SERIES PRICING

REFR. TYPE	NOM. HP	MODEL NUMBER	LIST PRICE			WATER REG. VALVE‡	CLEAN-ABLE COND.	LK	* SK	^ SUCTION LINE ACCUM.	OIL SEP.	4 Year Comp. Protection Plan	APPROX. SHIP WT. (LBS.)											
			230/3	230/1	460/3																			
MED. TEMP. R404A	1.0	RWO100M44	RW Series 1/2 to 6-1/2 H.P. Scroll models are no longer available. Use Next-Gen WC-Series models instead.																					
	1.5	RWO150M44																						
	2.0	RWO200M44																						
	2.5	RWO250M44																						
	3.0	RWO315M44																						
	3.0	RWO350M44																						
	4.0	RWO400M44																						
	6.0	RWO600M44																						
	6.5	RWO650M44																						
	7.5	RWO7M44												\$18,353	N/A	\$18,838	\$1,163	C/F	\$631	\$506	\$817	\$1,481	\$466 NET	405
7.5	RWO8M44	22,868	N/A	24,520	1,163	C/F	631	506	817	1,481	466 NET	450												
10.0	RWO10M44	28,397	N/A	29,210	1,163	C/F	849	858	1,201	1,481	504 NET	665												
13.0	RWO13M44	28,901	N/A	29,775	1,502	C/F	1,065	1,369	2,508	1,741	582 NET	675												
LOW TEMP. R404A	2.0	RWO200L44	RW Series 1/2 to 6-1/2 H.P. Scroll models are no longer available. Use Next-Gen WC-Series models instead.																					
	2.5	RWO250L44																						
	3.0	RWO300L44																						
	3.0	RWO301L44																						
	4.0	RWO400L44																						
	5.0	RWO500L44																						
	6.0	RWO600L44																						
	7.5	RWO8L44												18,348	N/A	19,796	1,163	C/F	631	506	817	1,481	466 NET	470
	10.0	RWO10L44												23,053	N/A	24,762	1,163	C/F	849	858	1,201	1,481	504 NET	645
	13.0	RWO13L44												25,786	N/A	26,630	1,502	C/F	1,065	1,369	2,508	1,741	582 NET	670

RN SERIES PRICING

REFR. TYPE	NOM. HP	MODEL NUMBER	LIST PRICE			WATER REG. VALVE‡	CLEAN-ABLE COND.	LK	* SK	^ SUCTION LINE ACCUM.	OIL SEP.	4 Year Comp. Protection Plan	APPROX. SHIP WT. (LBS.)
			230/3	230/1	460/3								
MED. TEMP. R404A	2.0	RNO200M44	RN Series models are no longer available.										
	2.5	RNO250M44											
	3.0	RNO315M44											
	3.0	RNO350M44											
	4.0	RNO400M44											
	6.0	RNO600M44											
	6.5	RNO650M44											
	7.5	RNO7M44											
	7.5	RNO8M44											
	10.0	RNO10M44											
13.0	RNO13M44												
LOW TEMP. R404A	2.0	RNO200L44	RN Series models are no longer available.										
	2.5	RNO250L44											
	3.0	RNO300L44											
	3.0	RNO301L44											
	4.0	RNO400L44											
	5.0	RNO500L44											
	6.0	RNO600L44											
	7.5	RNO8L44											
	10.0	RNO10L44											
	13.0	RNO13L44											

* Suction line assembly option must be ordered to receive the Suction Accumulator pre-piped.

^ For pre-piped Suction Accumulator, the SK option must also be ordered.
C/F = Consult the factory for pricing.

‡ Water Reg. Valve shipped Loose for field installation.

OPTIONAL PIPING COMPONENTS			
*LIQUID LINE KIT		* SUCTION LINE KIT	
HP	Kit Num	HP	Kit Num
1/2 - 3	LK-MC1	1/2 - 3	*SK-MC-1
4 - 6	LK-MC2	4 - 6	*SK-MC-2
3 - 8	LK-4	3 - 8	SK-4
9 - 10	LK-5	9 - 10	SK-5
12 - 22	LK-6	12 - 22	SK-6

See pages 21 & 25 for piping component pricing.

ADDITIONAL OPTIONS FOR RW & RN UNITS	
DESCRIPTION	LIST PRICE
ANTI-SHORT CYCLE TIMER	\$694
GAUGE KIT, HIGH, LOW, AND OIL PRESSURE	1,941
PHASE LOSS MONITOR	1,175
OVERSIZED CONTROL PANEL (OCP)	663
ELECTRONIC OIL PRESSURE CONTROL (SOPC)	847
TWO-TIERED STACKING OPTION - 1 thru 6.5 HP	C/F
TWO-TIERED STACKING OPTION - 7 thru 13 HP	C/F

RN SERIES • REMOTE COMPRESSOR UNITS

3 THRU 40 H.P.

RN Series models are no longer available.

STANDARD FEATURES:

- Semi-Hermetic Copeland Discus (RND series) or Reed (RNS series) Compressors.
- Spring Mounted Compressor.
- Compressor Contactor and Control Circuit Fusing in a NEMA 1 enclosure.
- Head Cooling Fan (when required).
- Large Receiver with Isolation and Pressure Relief Valves.
- High / Low Pressure and Mechanical Oil Pressure Controls.
- Models up to 80 HP are available, Contact Factory for pricing.

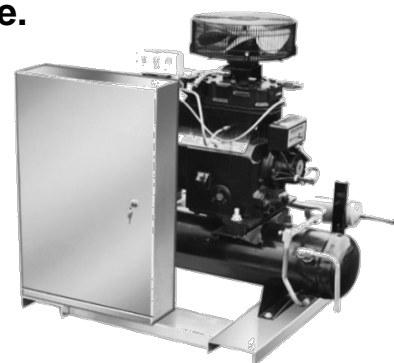

Shown with optional oversized control panel, liquid line assembly, suction line assembly and Electronic oil pressure control.

OPTIONAL FEATURES:

- Oversized Control Panel (OCP) required when adding defrost kits or other electrical components.
- Two tiered stacking racks.
- Remote Air Cooled Condensers are available, see pages 38-42
- All listed options are factory installed.

REFR. TYPE	NOM. H.P.	MODEL NUMBER	LIST PRICE		*LK	* SK	^ SUCTION LINE ACCUM.	OIL SEP.	4 Year Comp. Protection Plan	APPROX. SHIP WT. (LBS.)	
			208-230V/3	460V/3							
MED. TEMP. R404A	3.0	RNS3M44	<h1>RN Series models are no longer available</h1>								
	5.0	RND5M44									
	6.0	RND6M44									
	7.5	RND7M44									
	7.5	RND8M44									
	10.0	RND10M44									
	12.0	RND12M44									
	15.0	RND15M44									
	20.0	RND20M44									
	25.0	RND25M44									
LOW TEMP. R404A	3.0	RNS3L44									
	3.0	RND3L44									
	4.0	RND4L44									
	5.0	RND5L44									
	6.0	RND6L44									
	8.0	RND8L44									
	9.0	RND9L44									
	10.0	RND10L44									
	12.0	RND12L44									
	15.0	RND15L44									
22.0	RND22L44										
27.0	RND27L44										
30.0	RND30L44										

* Suction line assembly option must be ordered to receive the Suction Accumulator pre-piped.

^ For pre-piped Suction Accumulator, the SK option must also be ordered.

RE-HEAT KITS

Re-heat kits have been discontinued and are no longer available.

HEAT RECLAIM HEATER



MODEL NUMBER	CFM	QTY OF FANS	MOTOR HP	LIST PRICE		APPROX. SHIP WT. (LBS)
				208/230/1 460/1/60	208/230/3 460/3/60	
HACS001B-08	3,020	1	1/3	\$2,267	\$2,395	97
HACS001B-12	2,890	1	1/3	2,974	3,102	99
HACS002B-08	2,840	1	1/3	3,323	3,451	105
HACS003B-08	4,450	1	1/3	6,072	6,199	128
HACS005B-10	3,900	1	1/3	7,604	7,732	137
HACS008B-10	8,640	2	1/3	9,308	9,436	190
HACS010B-10	7,780	2	1/3	10,450	10,578	205
HACS012B-10	7,080	2	1/3	12,513	12,641	221

Specify voltage and discharge orientation(horizontal or vertical) when ordering

FREIGHT SURCHARGES

The following freight surcharges will be applied to orders (when applicable). For delivery and post delivery issues, the customer will be notified and a second invoice will be generated.

BASIC LTL FREIGHT SURCHARGES	NET Price [†]
Delivery Notification / Call before delivery	\$74
Lift Gate Service	231
Saturday Delivery Request	524
*Failed/Refused delivery attempt (minimum)	106
*Failed/Refused delivery attempt (Maximum)	1,314
Re-Consignment fee	99
Storage (Per 100 LBS for each calendar day)	5

BASIC CONTRACT HAUL SURCHARGES	NET [†]
Cancelled truck not used	\$2,337
Reconsignment fee	838
Reconsignment cost per mile (\$1566 Minimum)	3.49
Delay in unloading (4 hours or more past an appointment)	1,629

[†] Net prices are not to be discounted.

* Refused Delivery fee will be calculated @ 12.56 cents per 100 LBS, subject to Minimum and Maximum charges shown above (per incident).

[†] Net prices are not to be discounted.

APEX • TOP MOUNTED REFRIGERATION SYSTEM

Medium Temperature - Air Defrost

Model Number	Indoor List Price EC Evap Mtr	Outdoor List Price EC Evap Mtr	Indoor Power Cord	Volts/Ph/Hz	INDOOR NET / SHIP WT. (LBS.)	OUTDOOR NET / SHIP WT. (LBS.)	4 Year Compressor Protect. Plan Net Price
XN026MA44AE	\$5,718	N/A	Yes	115/1/60	120 / 185	N/A	\$81
XN029MA44AE	6,263	N/A	Yes	115/1/60	120 / 185	N/A	81
XN037MA44AE	6,459	N/A	Yes	115/1/60	125 / 190	N/A	81
XN050MA44AE	8,545	N/A	Yes	115/1/60	210 / 305	N/A	81
X*050MA44DE	8,552	\$9,712	Yes	208-230/1/60	210 / 305	220 / 360	81
X*068MA44DE	9,891	10,635	Yes	208-230/1/60	220 / 315	230 / 370	81
X*076MA44DE	10,567	11,578	Yes	208-230/1/60	220 / 315	230 / 375	81
X*106MA44DE	12,588	13,021	Yes	208-230/1/60	295 / 420	310 / 485	83
X*106MA44EE	11,810	12,978	No	208-230/3/60	305 / 430	320 / 495	83
X*134MA44DE	14,092	14,255	No	208-230/1/60	310 / 435	325 / 500	100
X*134MA44EE	12,915	14,172	No	208-230/3/60	310 / 435	325 / 500	100

Low Temperature - Electric Defrost

Model Number	Indoor List Price EC Evap Mtr	Outdoor List Price EC Evap Mtr	Indoor Power Cord	Volts/Ph/Hz	INDOOR NET / SHIP WT. (LBS.)	OUTDOOR NET / SHIP WT. (LBS.)	4 Year Compressor Protect. Plan Net Price
XN018LE44AE	\$9,355	N/A	Yes	115/1/60	140 / 200	N/A	\$81
X*024LE44AE	10,635	N/A	Yes	115/1/60	210 / 305	N/A	81
X*024LE44DE	11,275	\$11,158	Yes	208-230/1/60	210 / 305	225 / 365	81
X*031LE44DE	11,231	12,543	Yes	208-230/1/60	245 / 340	255 / 400	81
X*043LE44DE	12,505	14,370	Yes	208-230/1/60	245 / 340	255 / 400	83
X*051LE44DE	14,350	16,224	Yes	208-230/1/60	315 / 445	320 / 510	83
X*051LE44EE	14,346	16,093	No	208-230/3/60	315 / 445	320 / 510	83
X*068LE44DE	15,397	17,279	No	208-230/1/60	320 / 450	335 / 515	98
X*068LE44EE	15,385	17,268	No	208-230/3/60	320 / 450	335 / 515	98

NOMENCLATURE

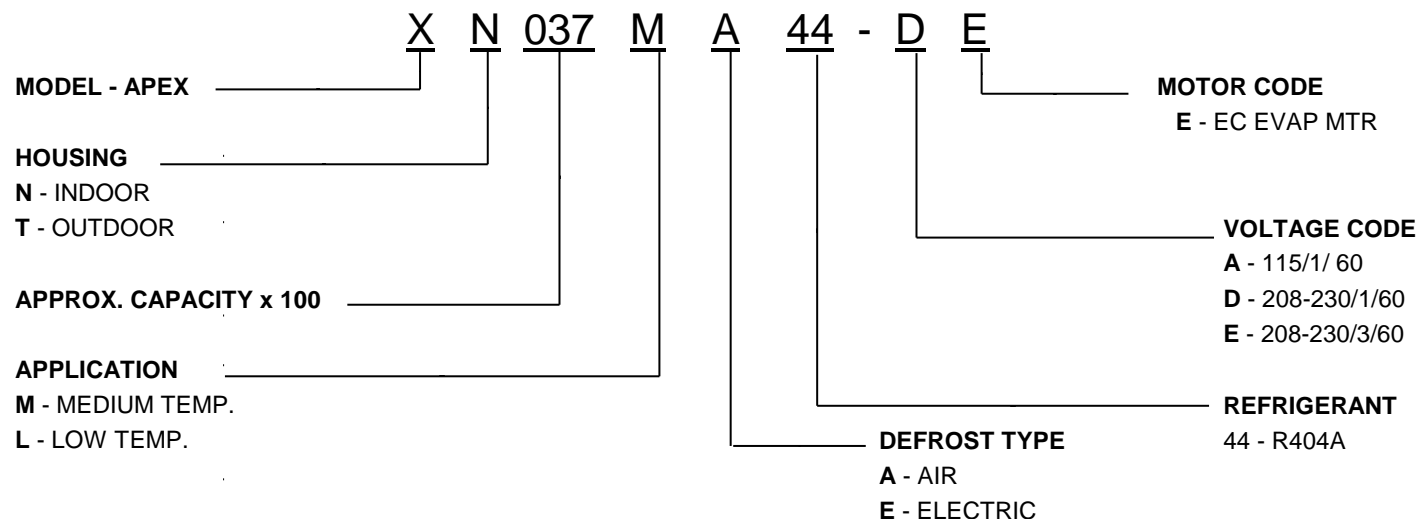

Save Time and Money

- Fully factory assembled, charged and tested.
- No piping or loose components to install which saves you labor cost \$\$\$.
- Adjustable digital controller is preset for typical cooler or freezer applications.
- **Two-year warranty on all parts***
See Apex IOM M900 for full Warranty Disclosure

* Insert character for housing code or motor code as applicable

Quick Installation

- Installs in a fraction of the time it takes for a typical split refrigeration systems.
- The supply/return register mounts flush with a standard 4" ceiling panel which provides for more storage in your cooler or freezer.
- Condensate is evaporated so no drain line is required on indoor models.
- Outdoor models come standard with a roof and drain line connection (see drawing in Catalog 509).

QUANTUM AIR™ REMOMTE AIR COOLED CONDENSER



Standard Features

- Inverter Duty rail mounted motors
- Vertical air flow
- Motors with inherent thermal overload protection
- 3/8" refrigerant saving copper tube, aluminum fin coils*
- 650 PSIG working pressure
- Vinyl coated heavy gauge steel fan guards
- Swept wing fan/Venturi improves airflow and sound
- Hinged Venturi panels for easy servicing
- Hinged leg design for simple installation
- Proprietary floating coil design
- Thru-the-door non-fused disconnect switch
- Heavy gauge painted galvanized steel construction
- Heavy duty lifting eyes for equipment rigging
- UL and cUL listed for outdoor use
- LED control panel lighting
- California Title 24 compliant - see pages 43-44 for applicable models and details

Options

- Fan cycling head pressure control
- Flooded head pressure control
- Subcooling circuit
- Horizontal air flow
- Multi-circuited coils
- Wide selection of fin coatings and materials
- Individual motor fusing
- Individual or paired motor contactors
- EMS control options
- Variable frequency drives
- Multiple control panel locations
- Multiple refrigerant options
- Thru-the-door fused disconnect
- Main circuit breaker disconnect
- Leg height up to 46" (18" standard)
- Fixed box style legs (25")

QUANTUM AIR™ AIR COOLED CONDENSER NOMENCLATURE - LARGE MODELS (Page 49 - 52)

R	D	D	0	8	7	G	D	3	A
1	2	3	4	5	6	7	8	9	10
Position Number and Description									
1	Model Series - R = Russell Model				8	Motor			
2	Unit Type - D = Condenser					B – 1140 RPM, 1.5 HP Motor			
3	Width					D – 850 RPM, 1.5 HP Motor			
	S = Single Wide					L – 850 RPM, 1 HP Motor			
	D = Double Wide					E – 550 RPM, 1/3 HP Motor			
4-6	Capacity (MBTUH)**					G – 900 RPM Variable Speed EC Motor (Rail Mtd.)			
7	Voltage Code					K – 1200 RPM Variable Speed EC Motor (Rail Mtd.)			
	E – 208-230V/3/60		N – 200-220V/3/50			(Enclosed Motors are an option available for certain Voltage/RPM combinations)			
	G – 460V/3/60		Q – 380V/3/50						
	J – 575V/3/60		X – Other - Non-catalogued		9	Number of Fans Long - 1 to 7			
					10	Vintage Code			

AIR COOLED CONDENSER NOMENCLATURE - SMALL MODELS (Page 48)

R	D	S	007	D	A	2	B	1	2	A	1	A
I	II	III	IV	V	VI	VII	VIII	IX	X	XI	XII	XIII
I.	Model Series R – Russell						IX.	Coil Material and Coating Options* 1 – Aluminum fins 2 – Copper fins 3 – Al + AST coating 6 – Al + Heresite 7 – Al + Polyester coat - Pre Coated Fin Material X – Other				
II.	Unit Type D – Condenser						X.	Housing Material and Coatings* 1 – Aluminum 7 – Stainless Steel 316L 2 – Galvanized X – Other				
III.	Series S – Single fan wide						XI.	Unit Design Configuration A – Vertical Fan Discharge, Standard Legs E – Vertical Fan Discharge, 30" Legs N – Horizontal Fan Discharge, Standard Legs				
IV.	Capacity – Three Number Characters						XII.	Circuit Splitting Options 1 – Full 2 – 50/50 X – Other				
V.	Voltage Code A – 115V/1/60 H – 575V/1/60 D – 208-230V/1/60 X – Other E – 208-230V/3/60 F – 460V/1/60 Codes D, E, F, and G can G – 460V/3/60 be used with 50 or 60 Hz power						XIII.	Revision Code – Single Alphanumeric Character A – Initial Release				
VI.	Motor/Fan Type A – 1140 RPM, 0.33 HP, Metal Blade C – 850 RPM, 0.25 HP, Metal Blade H – 1140 RPM, 0.5 HP Totally Enclosed, Metal Blade X – Other											
VII.	Length in Fans – 1 or 2											
VIII.	Coil Density A – 8 fpi D – 14 fpi B – 10 fpi X – Other C – 12 fpi											

* Contact Application Engineering to obtain price quotes for special fin materials or coatings.

When ordering please specify: Motor Voltage, Control Voltage (24, 115V or 208V), Internal or External Control Power, Design Ambient Temperature, the number of compressor systems and FPI required. Also provide the Refrigerant type, THR, T.D. for each compressor system.

SMALL CONDENSERS

1075 RPM .33 HP MOTORS

Model Number	10 FPI List Price	Fan Configuration	Approx Net Weight (LBS.)
RDS001DA1B12A1A	\$2,267	1 x 1	80
RDS002DA1B12A1A	2,974	1 x 1	86
RDS003DA1B12A1A	3,323	1 x 1	107
RDS005DA1B12A1A	6,072	1 x 1	116
RDS007DA2B12A1A	7,604	1 x 2	164
RDS009DA2B12A1A	9,308	1 x 2	179
RDS011DA2B12A1A	10,450	1 x 2	195

850 RPM .25 HP MOTORS

Model Number	10 FPI List Price	Fan Config.	Approx Net Weight (LBS.)
RDS001DC1B12A1A	\$2,486	1 x 1	80
RDS002DC1B12A1A	3,566	1 x 1	86
RDS003DC1B12A1A	4,078	1 x 1	107
RDS004DC1B12A1A	6,437	1 x 1	116
RDS006DC2B12A1A	7,938	1 x 2	164
RDS008DC2B12A1A	9,981	1 x 2	179
RDS009DC2B12A1A	10,848	1 x 2	195

1075 RPM .33 HP MOTORS - Totally Enclosed

Model Number	10 FPI List Price	Fan Config.	Approx. Net Weight (LBS.)
RDS001DH1B12A1A	\$3,299	1 x 1	80
RDS002DH1B12A1A	4,007	1 x 1	86
RDS003DH1B12A1A	4,356	1 x 1	107
RDS005DH1B12A1A	7,103	1 x 1	116
RDS007DH2B12A1A	9,668	1 x 2	164
RDS009DH2B12A1A	11,371	1 x 2	179
RDS011DH2B12A1A	12,513	1 x 2	195

POSITION V - Available Voltage Options*

Voltage Code	Adders Per Fan section	Available Based Upon Position VI - Motor Options
A-115/1/60	N/C	Only available with motor option A
D-208-230/1/60	—	Available with motor options A & C
E-208-230/3/60	\$128	Available with motor options A, C, & H
F-460/1/60	N/C	Available with motor options A & C
G-460/3/60	128	Available with motor options A, C, & H
H-575/1/60	50	Only available with motor option A

Note: "N/A" = Not available, "N/C" = No additional charge, "—" = Base Model Feature

POSITION VI - Available Motor / Fan Type Options

Motor Type	Adder Per Fan	Available Based Upon Position V - Voltage Options
A- 1075, 0.33HP	—	Available in Voltage codes A, D, E, F, G, H
C- 850 RPM, 0.25HP	—	Available in Voltage codes D, E, F, G
H - 1075, 0.5 HP	—	Available in Voltage codes E, G

Note: "N/A" = Not available, "N/C" = No additional charge, "—" = Base Model Feature

Position - VII - Indicates Length in Fans (1 or 2)

Position - VIII - Coil Density Options Price Add or Deduct (8FPI)

Fan Configuration	A - 8 FPI	B - 10 FPI	C - 12 FPI	D - 14 FPI
1 X 1	(\$391)	—	\$393	\$786
1 X 2	(\$782)	—	\$786	\$1,570

Note: "N/A" = Not available, "N/C" = No additional charge, "—" = Base Model Feature

Position - IX - Coil Material and Coating Options**

Aluminum fins (Standard) / Copper fins / Other

No Coating (Standard) / Al + AST coating / Al + Heresite coating / Al + Polyester coat - Pre Coated Fin Material / Other

Position - X - Housing Material and Coating Options**

Galvanized (Standard) / Aluminum / Stainless Steel 316L / Other

Position - XI - Unit Design Configuration

Leg Configuration	Fan Config. 1 x 1	Fan Config. 1 x 2
A – Vertical Fan Discharge, Standard 15" Legs	—	—
E – Vertical Fan Discharge, 30" Legs	\$142	\$284
N – Horizontal Fan Discharge, Standard Legs	—	—

Position - XII - Circuit Splitting Options**

Full (Standard) / 50/50 / Multi-Circuiting / Subcooling Circuit / Other

Available Options**

Fan cycling head pressure control (2 fan model only)

Variable speed fan control (header end fan only)

Flooded head pressure control (shipped loose)

Notes:

* Codes D, E, F and G can be used with 50 or 60 Hz power.

** Contact Application Engineering to obtain price quotes for special fin materials, coating, circuit splitting and available options.

1. Horizontal discharge orientation is available using standard leg arrangement code A.

2. Floating coil is not available for small condensers.

QUANTUM AIR™ LARGE CONDENSERS

1140 RPM 1.5 HP MOTORS (Code B)

SINGLE FAN WIDTH						
Model Number	8 FPI	10 FPI	12 FPI	14 FPI	Fans	Approx. Net Weight (LBS.)
RDS004^B1	\$7,040	\$7,460	\$7,867	\$8,273	1 x 1	350
RDS006^B1	8,963	9,383	9,791	10,197	1 x 1	375
RDS007^B1	10,009	10,429	10,836	11,242	1 x 1	400
RDS012^B2	14,722	15,564	16,377	17,190	1 x 2	725
RDS015^B2	20,264	21,106	21,919	22,732	1 x 2	750
RDS018^B2	24,014	24,855	25,668	26,482	1 x 2	775
RDS022^B3	29,635	30,897	32,117	33,337	1 x 3	1,125
RDS027^B3	34,503	35,766	36,986	38,205	1 x 3	1,150
RDS030^B4	41,403	43,086	44,713	46,339	1 x 4	1,500
RDS036^B4	46,835	48,518	50,145	51,771	1 x 4	1,525
RDS039^B5	51,656	53,760	55,793	57,826	1 x 5	1,875
RDS047^B5	60,101	62,204	64,238	66,271	1 x 5	1,900
RDS056^B6	71,923	74,448	76,888	79,328	1 x 6	2,275
RDS065^B7	84,511	87,457	90,303	93,150	1 x 7	2,650

850 RPM 1.5 HP MOTORS (Code D)

SINGLE FAN WIDTH						
Model Number	8 FPI	10 FPI	12 FPI	14 FPI	Fans	Approx. Net Weight (LBS.)
RDS004^D1	\$6,966	\$7,387	\$7,794	\$8,200	1 x 1	350
RDS005^D1	8,906	9,326	9,732	10,139	1 x 1	375
RDS007^D1	9,923	10,344	10,750	11,157	1 x 1	400
RDS010^D2	15,057	15,898	16,713	17,526	1 x 2	725
RDS014^D2	20,204	21,045	21,859	22,672	1 x 2	750
RDS015^D2	22,405	23,246	24,059	24,873	1 x 2	775
RDS021^D3	29,813	31,075	32,295	33,515	1 x 3	1,125
RDS024^D3	33,754	35,016	36,237	37,457	1 x 3	1,150
RDS028^D4	40,491	42,174	43,801	45,427	1 x 4	1,500
RDS032^D4	45,406	47,089	48,716	50,342	1 x 4	1,525
RDS035^D5	49,509	51,613	53,646	55,681	1 x 5	1,875
RDS043^D5	59,432	61,536	63,569	65,603	1 x 5	1,900
RDS052^D6	71,316	73,840	76,280	78,721	1 x 6	2,275
RDS060^D7	83,616	86,561	89,408	92,254	1 x 7	2,650

DOUBLE FAN WIDTH

Model Number	8 FPI	10 FPI	12 FPI	14 FPI	Fans	Approx. Net Weight (LBS.)
RDD022^B2	\$30,406	\$32,089	\$33,716	\$35,343	2 x 2	1,500
RDD030^B2	40,459	42,142	43,768	45,395	2 x 2	1,525
RDD036^B2	47,116	48,799	50,425	52,052	2 x 2	1,550
RDD045^B3	60,519	63,043	65,483	67,922	2 x 3	2,275
RDD054^B3	70,806	73,330	75,771	78,211	2 x 3	2,300
RDD059^B4	81,028	84,395	87,648	90,901	2 x 4	3,025
RDD072^B4	93,526	96,893	100,146	103,399	2 x 4	3,050
RDD078^B5	103,315	107,522	111,589	115,656	2 x 5	3,775
RDD094^B5	120,384	124,591	128,658	132,725	2 x 5	3,800
RDD113^B6	143,830	148,878	153,759	158,638	2 x 6	4,550
RDD131^B7	169,438	175,327	181,021	186,715	2 x 7	5,300

DOUBLE FAN WIDTH

Model Number	8 FPI	10 FPI	12 FPI	14 FPI	Fans	Approx. Net Weight (LBS.)
RDD019^D2	\$29,294	\$30,976	\$32,603	\$34,230	2 x 2	1,500
RDD028^D2	40,341	42,024	43,651	45,277	2 x 2	1,525
RDD031^D2	44,056	45,739	47,366	48,992	2 x 2	1,550
RDD041^D3	60,001	62,526	64,966	67,406	2 x 3	2,275
RDD048^D3	68,127	70,651	73,092	75,532	2 x 3	2,300
RDD055^D4	81,070	84,436	87,689	90,943	2 x 4	3,025
RDD065^D4	91,002	94,368	97,622	100,875	2 x 4	3,050
RDD069^D5	98,978	103,185	107,252	111,318	2 x 5	3,775
RDD086^D5	119,075	123,283	127,349	131,416	2 x 5	3,800
RDD103^D6	142,702	147,751	152,630	157,511	2 x 6	4,550
RDD121^D7	167,254	173,144	178,837	184,531	2 x 7	5,300

^ Insert voltage code here.

\$228 List price adder per fan 575/3/60 motors.

\$876 List Price adder (per fan) for Totally Enclosed Motor. 1.5 HP 1140 or 850 RPM, or 1.0 HP 850 RPM only. Not available for 550 RPM models.

^ Insert voltage code here.

575V motors are not available for units with 850RPM, 1.5 HP motors.

QUANTUM AIR™ LARGE CONDENSERS

850 RPM 1.0 HP MOTORS (Code L)†

SINGLE FAN WIDTH						
Model Number	8 FPI	10 FPI	12 FPI	14 FPI	Fans	Approx. Net Weight (LBS.)
RDS004^L1	\$6,510	\$6,932	\$7,338	\$7,745	1 x 1	350
RDS006^L1	8,429	8,850	9,257	9,664	1 x 1	375
RDS008^L1	10,076	10,497	10,903	11,310	1 x 1	400
RDS010^L2	14,140	14,982	15,796	16,609	1 x 2	725
RDS012^L2	17,840	18,682	19,495	20,309	1 x 2	750
RDS015^L2	21,570	22,411	23,224	24,038	1 x 2	775
RDS019^L3	28,183	29,444	30,665	31,885	1 x 3	1,125
RDS023^L3	32,254	33,516	34,736	35,956	1 x 3	1,150
RDS026^L4	39,019	40,702	42,329	43,956	1 x 4	1,500
RDS030^L4	44,255	45,938	47,565	49,192	1 x 4	1,525
RDS032^L5	47,522	49,626	51,659	53,692	1 x 5	1,875
RDS040^L5	58,534	60,638	62,671	64,705	1 x 5	1,900
RDS048^L6	70,625	73,150	75,590	78,030	1 x 6	2,275
RDS056^L7	82,645	85,590	88,436	91,283	1 x 7	2,650

550 RPM 1/3 HP MOTORS (Code E)†

SINGLE FAN WIDTH						
Model Number	8 FPI	10 FPI	12 FPI	14 FPI	Fans	Approx. Net Weight (LBS.)
RDS004^E1	\$7,519	\$7,939	\$8,346	\$8,753	1 x 1	350
RDS005^E1	8,851	9,272	9,678	10,085	1 x 1	375
RDS006^E1	9,972	10,393	10,799	11,206	1 x 1	400
RDS008^E2	14,821	15,662	16,476	17,289	1 x 2	725
RDS011^E2	19,533	20,375	21,188	22,001	1 x 2	750
RDS012^E2	21,602	22,443	23,258	24,071	1 x 2	775
RDS016^E3	29,896	31,158	32,378	33,598	1 x 3	1,125
RDS018^E3	32,763	34,026	35,246	36,466	1 x 3	1,150
RDS021^E4	40,979	42,662	44,288	45,916	1 x 4	1,500
RDS025^E4	45,947	47,630	49,256	50,883	1 x 4	1,525
RDS028^E5	52,062	54,166	56,200	58,233	1 x 5	1,875
RDS032^E5	57,703	59,807	61,840	63,875	1 x 5	1,900
RDS040^E6	73,421	75,945	78,385	80,826	1 x 6	2,275
RDS046^E7	85,835	88,781	91,627	94,474	1 x 7	2,650

DOUBLE FAN WIDTH

Model Number	8 FPI	10 FPI	12 FPI	14 FPI	Fans	Approx. Net Weight (LBS.)
RDD017^L2	\$27,245	\$28,928	\$30,554	\$32,182	2 x 2	1,500
RDD026^L2	39,004	40,687	42,313	43,940	2 x 2	1,525
RDD030^L2	44,273	45,956	47,582	49,209	2 x 2	1,550
RDD038^L3	58,977	61,501	63,941	66,381	2 x 3	2,275
RDD046^L3	68,816	71,341	73,781	76,221	2 x 3	2,300
RDD051^L4	79,196	82,562	85,816	89,069	2 x 4	3,025
RDD060^L4	90,199	93,566	96,819	100,072	2 x 4	3,050
RDD063^L5	96,134	100,341	104,409	108,475	2 x 5	3,775
RDD080^L5	118,636	122,843	126,910	130,977	2 x 5	3,800
RDD097^L6	142,484	147,533	152,413	157,294	2 x 6	4,550
RDD113^L7	166,997	172,888	178,582	184,274	2 x 7	5,300

DOUBLE FAN WIDTH

Model Number	8 FPI	10 FPI	12 FPI	14 FPI	Fans	Approx. Net Weight (LBS.)
RDD016^E2	\$31,769	\$33,453	\$35,079	\$36,706	2 x 2	1,500
RDD021^E2	40,979	42,662	44,288	45,916	2 x 2	1,525
RDD025^E2	45,538	47,221	48,848	50,474	2 x 2	1,550
RDD032^E3	62,883	65,407	67,848	70,287	2 x 3	2,275
RDD037^E3	68,868	71,393	73,833	76,273	2 x 3	2,300
RDD043^E4	84,134	87,499	90,754	94,007	2 x 4	3,025
RDD050^E4	93,731	97,096	100,351	103,604	2 x 4	3,050
RDD055^E5	107,329	111,536	115,603	119,670	2 x 5	3,775
RDD063^E5	117,833	122,041	126,107	130,175	2 x 5	3,800
RDD080^E6	149,414	154,463	159,343	164,223	2 x 6	4,550
RDD093^E7	173,739	179,630	185,323	191,017	2 x 7	5,300

^ Insert voltage code here.

575V motors are not available for units with 550RPM, 1/3 HP motors.

\$876 List Price adder (per fan) for Totally Enclosed Motor. 1.5 HP 1140 or 850 RPM, or 1.0 HP 850 RPM only. Not available for 550 RPM models.

† These models fulfill California Title 24 condenser efficiency requirements when utilizing Variable Frequency Drives and 10 FPI coils.

^ Insert voltage code here.

QUANTUM AIR™ LARGE CONDENSERS

VSEC 1200 RPM (Code K)

SINGLE FAN WIDTH

Model Number	8 FPI	10 FPI	12 FPI	14 FPI	Fans	Approx. Net Weight (LBS.)
RDS005^K1	\$12,772	\$13,192	\$13,599	\$14,006	1 x 1	350
RDS006^K1	14,695	15,115	15,523	15,930	1 x 1	375
RDS008^K1	15,741	16,162	16,568	16,975	1 x 1	400
RDS013^K2	26,187	27,029	27,842	28,655	1 x 2	725
RDS016^K2	31,729	32,571	33,384	34,197	1 x 2	750
RDS019^K2	35,479	36,320	37,133	37,946	1 x 2	775
RDS024^K3	46,832	48,095	49,315	50,535	1 x 3	1,125
RDS028^K3	51,700	52,963	54,183	55,403	1 x 3	1,150
RDS032^K4	64,333	66,016	67,643	69,269	1 x 4	1,500
RDS038^K4	69,765	71,448	73,075	74,701	1 x 4	1,525
RDS041^K5	80,318	82,422	84,455	86,488	1 x 5	1,875
RDS049^K5	88,763	90,867	92,900	94,933	1 x 5	1,900
RDS059^K6	106,318	108,843	111,283	113,723	1 x 6	2,275
RDS069^K7	124,639	127,584	130,431	133,277	1 x 7	2,650

VSEC 900 RPM (Code L)

SINGLE FAN WIDTH

Model Number	8 FPI	10 FPI	12 FPI	14 FPI	Fans	Approx. Net Weight (LBS.)
RDS004^G1	\$12,772	\$13,192	\$13,599	\$14,006	1 x 1	350
RDS005^G1	14,695	15,115	15,523	15,930	1 x 1	375
RDS007^G1	15,741	16,162	16,568	16,975	1 x 1	400
RDS010^G2	26,187	27,029	27,842	28,655	1 x 2	725
RDS014^G2	31,729	32,571	33,384	34,197	1 x 2	750
†RDS015^G2*	35,479	36,320	37,133	37,946	1 x 2	775
RDS021^G3	46,832	48,095	49,315	50,535	1 x 3	1,125
†RDS025^G3*	51,700	52,963	54,183	55,403	1 x 3	1,150
RDS028^G4	64,333	66,016	67,643	69,269	1 x 4	1,500
†RDS033^G4*	69,765	71,448	73,075	74,701	1 x 4	1,525
RDS035^G5	80,318	82,422	84,455	86,488	1 x 5	1,875
†RDS044^G5*	88,763	90,867	92,900	94,933	1 x 5	1,900
†RDS052^G6*	106,318	108,843	111,283	113,723	1 x 6	2,275
†RDS061^G7*	124,639	127,584	130,431	133,277	1 x 7	2,650

DOUBLE FAN WIDTH

Model Number	8 FPI	10 FPI	12 FPI	14 FPI	Fans	Approx. Net Weight (LBS.)
RDD023^K2	\$53,336	\$55,019	\$56,646	\$58,273	2 x 2	1,500
RDD032^K2	63,389	65,072	66,698	68,325	2 x 2	1,525
RDD038^K2	70,046	71,729	73,355	74,982	2 x 2	1,550
RDD047^K3	94,914	97,438	99,877	102,317	2 x 3	2,275
RDD057^K3	105,201	107,725	110,166	112,606	2 x 3	2,300
RDD063^K4	126,888	130,255	133,508	136,761	2 x 4	3,025
RDD075^K4	139,386	142,752	146,006	149,259	2 x 4	3,050
RDD082^K5	160,639	164,847	168,914	172,981	2 x 5	3,775
RDD099^K5	177,709	181,916	185,983	190,050	2 x 5	3,800
RDD118^K6	212,620	217,668	222,549	227,428	2 x 6	4,550
RDD138^K7	249,700	255,590	261,283	266,977	2 x 7	5,300

DOUBLE FAN WIDTH

Model Number	8 FPI	10 FPI	12 FPI	14 FPI	Fans	Approx. Net Weight (LBS.)
RDD020^G2	\$53,336	\$55,019	\$56,646	\$58,273	2 x 2	1,500
RDD028^G2	63,389	65,072	66,698	68,325	2 x 2	1,525
†RDD032^G2*	70,046	71,729	73,355	74,982	2 x 2	1,550
RDD042^G3	94,914	97,438	99,877	102,317	2 x 3	2,275
†RDD049^G3*	105,201	107,725	110,166	112,606	2 x 3	2,300
RDD056^G4	126,888	130,255	133,508	136,761	2 x 4	3,025
†RDD065^G4*	139,386	142,752	146,006	149,259	2 x 4	3,050
RDD070^G5	160,639	164,847	168,914	172,981	2 x 5	3,775
†RDD087^G5*	177,709	181,916	185,983	190,050	2 x 5	3,800
†RDD105^G6*	212,620	217,668	222,549	227,428	2 x 6	4,550
†RDD122^G7*	249,700	255,590	261,283	266,977	2 x 7	5,300

^ Insert voltage code here.

^ Insert voltage code here.

† These selected models fulfill California Title 24 condenser efficiency requirements when utilizing 10 FPI coils.

Large Air Cooled Condenser Options

Fan configuration

	1X1	1X2	1X3	1X4	1X5	1X6	1X7	2X2	2X3	2X4	2X5	2X6	2X7
Disconnect Options													
Through the door non-fused disconnect	STD	STD	STD	STD	STD	STD	STD	STD	STD	STD	STD	STD	STD
Through the door fused disconnect	\$460	528	779	884	972	1,063	1,151	884	1,063	1,371	1,682	1,994	2,303
Main Power Circuit Breaker	\$944	944	1,168	1,168	1,168	1,168	1,168	1,168	1,168	1,252	1,252	1,252	1,252
Bladed Safety Switch, Non-fused	\$841	841	1,620	1,620	1,620	1,620	1,620	1,620	1,620	2,044	2,044	2,044	2,044
110 VAC - 20 Amp Convenience Outlet powered by separate building feed or transformer	\$339	339	339	339	339	339	339	339	339	339	339	339	339

Fan Cycling Options - Requires Contactor Option													
Ambient fan cycling†	—	\$938	1,279	1,704	2,128	2,554	2,981	937	1,279	1,704	2,128	2,554	2,981
Mechanical Pressure fan cycling (per circuit) W/O Header†	—	\$1,411	1,544	2,058	2,573	3,088	3,600	1,411	1,544	2,058	2,573	3,088	3,600
Mechanical Pressure fan cycling (per circuit) W/ Header†	—	\$1,798	2,314	2,832	3,350	3,867	4,394	1,798	2,314	2,832	3,350	3,867	4,394
Electronic Pressure fan cycling (per circuit) W/O Header†	—	\$1,464	1,835	3,047	4,261	5,472	6,427	1,464	1,835	3,047	4,261	5,472	6,427
Electronic Pressure fan cycling (per circuit) W/ Header†	—	\$2,079	3,291	4,503	5,717	6,661	7,827	2,079	3,291	4,503	5,717	6,661	7,827

Note: Header fan is continuous run and not cycled.

Electronic Header End Fan Speed Control - Req. Contactor & Fan Cycle on 1x2 and Larger													
Variable speed header end fan (1 or 2 Circuit) ambient controlled†	\$2,332	2,655	2,994	3,421	3,847	4,274	4,699	2,653	3,079	3,509	3,935	4,363	4,789
Variable speed header end fan (1 or 2 Circuit) Mechanical control - pressure†	\$2,780	2,986	3,303	3,816	4,333	4,847	5,359	2,986	3,303	3,816	4,333	4,847	5,359
Variable speed header end fan (1 or 2 Circuit) Electronic control - pressure†	\$2,944	3,261	3,593	4,806	6,020	6,952	8,120	3,261	3,593	4,806	6,020	6,952	8,120

Variable Frequency Drive (VFD)													
VFD Package - Shipped Loose†	C/F	C/F	C/F	C/F	C/F	C/F	C/F	C/F	C/F	C/F	C/F	C/F	C/F
VFD Package - Factory Mounted†	C/F	C/F	C/F	C/F	C/F	C/F	C/F	C/F	C/F	C/F	C/F	C/F	C/F

Control Boards - Items with this mark also ‡ require the contactor option													
CPC relay board + xfmr (1x1 thru 2x4 config) ‡	\$3,028	3,028	3,028	3,028	3,028	3,028	3,028	3,028	3,028	3,028	—	—	—
CPC relay boards (2)+ xfmr (2x5 thru 2x7 config) ‡	—	—	—	—	—	—	—	—	—	—	\$5,678	5,678	5,678
CPC relay board condenser split 50/50 (1 board + relay)	\$3,151	3,151	3,151	3,151	3,151	3,151	3,151	3,151	3,151	3,151	3,151	3,151	3,151
CPC analog speed control board and transformer	\$3,170	3,170	3,170	3,170	3,170	3,170	3,170	3,170	3,170	3,170	3,170	3,170	3,170
DANFOSS relay board + xfmr (1x1 thru 2x4 config) ‡	\$3,040	3,040	3,040	3,040	3,040	3,040	3,040	3,040	3,040	3,040	—	—	—
DANFOSS relay boards (2) + xfmr (2x5 thru 2x7 config) ‡	—	—	—	—	—	—	—	—	—	—	\$6,231	6,231	6,231
DANFOSS relay board condenser split 50/50 (relay) ‡	\$4,464	4,464	4,464	4,464	4,464	4,464	4,464	4,464	4,464	4,464	4,464	4,464	4,464
DANFOSS analog speed control board and transformer	\$3,510	3,510	3,510	3,510	3,510	3,510	3,510	3,510	3,510	3,510	3,510	3,510	3,510
VSEC Stand alone motor control (C450)	\$4,608	4,608	4,608	4,608	4,608	4,608	4,608	4,608	4,608	4,608	4,608	4,608	4,608

Consult Application Engineering For Other Relay Board Options

Control Options													
Control Circuit Breaker (2P - 15A)	\$303	303	303	303	303	303	303	303	303	303	303	303	303
Control circuit transformer†	\$573	573	573	573	573	573	573	573	573	573	573	573	573

Fan Control Options (Contactors)													
Individual Motor Contactors†	\$241	482	721	961	1,200	1,440	1,680	961	1,440	1,919	2,399	2,879	3,358
Paired Motor Contactors†	—	—	—	—	—	—	—	\$482	722	962	1,202	1,442	1,683
NEMA rated Contactors - Individual†	\$988	1,976	2,963	3,950	4,937	5,925	6,912	3,950	5,925	7,899	9,874	11,848	13,823
NEMA rated Contactors - PAIRED†	—	—	—	—	—	—	—	\$1,976	2,963	3,950	4,937	5,925	6,912
Individual motor fuses†	\$243	486	727	969	1,212	1,453	1,695	969	1,453	1,938	2,422	2,906	3,390
Paired motor fuses†	—	—	—	—	—	—	—	\$486	727	969	1,212	1,453	1,695
Individual circuit breakers††	\$674	967	1,439	1,928	2,400	2,889	3,336	1,928	2,889	3,834	4,799	5,762	6,444
Paired circuit breakers††	—	—	—	—	—	—	—	\$967	1,439	1,928	2,400	2,889	3,336
Individual motor terminal boards†	\$171	338	506	674	844	1,012	1,179	674	1,012	1,618	1,956	2,290	2,628
Paired motor terminal blocks†	—	—	—	—	—	—	—	\$338	506	674	844	1,012	1,179
Fan toggle switches - per fan (to control contactors)†	\$101	203	301	401	501	602	702	401	602	803	1,003	1,202	1,402
Fan toggle switches - PAIRED (to control contactors)†	—	—	—	—	—	—	—	\$203	301	401	501	602	702
Fan toggle switches - per fan (to control Motors)†	\$460	460	460	460	460	460	460	1,616	2,423	3,231	4,039	4,846	5,654
Fan toggle switches - PAIRED (to control Motors)†	—	—	—	—	—	—	—	\$808	1,212	1,616	2,020	2,423	2,828

Build Options**													
Horizontal Air Discharge	\$680	996	1,466	1,799	2,116	2,434	2,731	1,992	2,901	3,598	4,231	4,866	5,466
Aluminum Housing	\$270	541	811	1,081	1,351	1,621	1,891	1,081	1,621	2,161	2,702	3,242	3,781
Stainless Steel Housing	C/A	C/A	C/A	C/A	C/A	C/A	C/A	C/A	C/A	C/A	C/A	C/A	C/A
Leg length - 21" or 30" - Standard Vertical air discharge	\$142	284	424	424	424	523	665	284	424	424	424	523	665
Leg length - 46" (Vertical air discharge only)	\$170	336	502	502	502	618	784	336	502	502	502	618	784
Box Style Leg at every location- 25" (Vertical air discharge only)	\$494	740	987	1,233	1,480	1,726	1,973	740	987	1,233	1,480	1,726	1,973
Sealtite wiring to motor rail	\$212	263	398	536	662	798	931	536	798	1,063	1,331	1,595	1,851
Sealtite wiring to electrical box	\$702	1,404	2,106	2,807	3,509	4,211	4,913	2,807	4,211	5,614	7,018	8,421	9,825
Condenser Base with 18" legs (Vertical air discharge only)	\$1,722	2,485	3,250	4,015	4,780	5,545	6,310	2,485	3,250	4,015	4,780	5,545	6,310
Condenser Base with 30 or 46" legs (Vertical air discharge only)	\$1,843	2,729	3,614	4,500	5,385	6,270	7,155	2,729	3,614	4,500	5,385	6,270	7,155
Condenser / Receiver Assembly (Vertical air discharge only)	C/A	C/A	C/A	C/A	C/A	C/A	C/A	C/A	C/A	C/A	C/A	C/A	C/A
Header End control panel mounting (Specify location change)	N/C	N/C	N/C	N/C	N/C	N/C	N/C	N/C	N/C	N/C	N/C	N/C	N/C

Flooded Head Pressure Controls (Shipped loose only)													
List Price per compressor system†	C/A	C/A	C/A	C/A	C/A	C/A	C/A	C/A	C/A	C/A	C/A	C/A	C/A
Number of Controls per compressor system†	C/A	C/A	C/A	C/A	C/A	C/A	C/A	C/A	C/A	C/A	C/A	C/A	C/A
Manifold included†	C/A	C/A	C/A	C/A	C/A	C/A	C/A	C/A	C/A	C/A	C/A	C/A	C/A

* Multiple valves or manifolds are required for multi-circuit condensers.

** Contact Application Engineering to obtain price quotes for special fin materials or coatings.

N/C = No additional charge for this feature.

C/A = Contact Application engineering for custom price quote.

† This option is not available for condensers with VSEC motors.

†† Units with VSEC motors **include** individual circuit breaker. Paired circuit breakers are not available.



PRINCIPAL TERMS AND CONDITIONS OF SALE

Supersedes all earlier versions

Prices effective 7/2/18

1. **Applicable Law and Terms of Sale:** All orders shall be subject to the following terms and conditions notwithstanding any additional or contrary printed terms and conditions of Buyer. Such additional or contrary terms shall not bind Seller unless accepted in writing even though such terms do not materially alter the terms hereof. No oral statements, warranties, stipulations, representations or terms shall have any binding effect or be any part of the contract whatsoever.
2. **Orders:** All orders must be in writing and will be binding when our order acknowledgment is mailed. Orders are accepted subject to strikes, fires, accidents, and other causes beyond our reasonable control. Acceptance of your order is conditioned upon an agreement to hold us harmless by reason of delivery delays.
3. **Prices:** Prices are subject to change without notice, and all quotations, unless otherwise specified, are binding only for immediate acceptance. Prices are based on material made to Seller's standard tolerances, unless otherwise specified.
4. **Freight:** All products are shipped FOB Point of Shipment with full freight allowed on single orders with a net price value of \$10,000.00 or more, except surface coils and parts, within the continental USA (excluding Alaska and Hawaii). Shipments to destinations outside the continental USA, that meet freight allowance requirements, will incur charges for the additional transport beyond the USA border. Seller reserves the choice of transportation mode (DRY VAN, FLATBED, LTL, AND PARCEL), carrier, and shipping point. For special routing requests, Buyer will bear all additional costs for such routing. The responsibility of the Seller shall cease upon delivery of the product in good condition to a common carrier (TL, LTL, FLATBED, etc.). Since all goods are shipped at Buyer's risk, they should carefully examine before signing delivery receipt. If common carrier tenders delivery of goods in damaged condition or if packages delivered do not correspond with the number called for on the freight bill, Buyer should insist on common carrier's agent (DRIVER) making notation of the condition of shortages of damage on delivery receipt. The Buyer should never refuse freight from the common carrier. Filing freight claims are under the responsibility of the Buyer, and this will enable them to secure prompt payment of claim for damaged or lost material. Refer to HTPG's freight policy for further information.
5. **Taxes:** Any sales, use, excise, or similar tax payable by Seller which is or may be imposed by any taxing authority upon manufacture, sale or delivery of goods covered by any order or any increase in rate of any such tax now in force, shall be added to the sales price; if not collected at the time of payment of sales price, Buyer will hold Seller harmless.
6. **Limited Warranty:** Seller warrants against defect in materials and workmanship in products which it manufactures for (1) year from date of installation or up to (18) eighteen months from the date of shipment, whichever event occurs first, when properly installed and operated under normal use. This guarantee does not include any labor or other charges made outside of the Seller's factory for replacement or repair of defective parts unless specifically stated in the body of the Seller's invoice. On parts not manufactured by Seller, such as motors, controls, valves and compressors we extend to the Buyer the same warranties made to us by the manufacturer. Seller's only liability under this warranty or otherwise shall be the repair or replacement (at Seller's option) of non-conforming goods or parts. Seller assumes no liability for incidental or consequential damages such as injury to person or property, or lost profits.
7. **THIS GUARANTEE SUPERSEDES AND IS IN LIEU OF ANY AND ALL OTHER WARRANTIES BY LAW OR CUSTOM, EITHER EXPRESSED OR IMPLIED INCLUDING, BUT NOT LIMITED BY THIS ENUMERATION, ANY GUARANTEE AS TO QUALITY OR FITNESS FOR ANY PARTICULAR PURPOSE, EXCEPT AS SET FORTH ABOVE. NO PERSON, AGENT, OR DEALER IS AUTHORIZED TO GIVE ANY WARRANTIES ON BEHALF OF SELLER NOR TO ASSUME FOR SELLER ANY OTHER LIABILITY IN CONNECTION WITH ANY OF THE SELLER'S PRODUCTS.**
8. **Delivery:** Seller shall not be liable for any delays in or failure of delivery due to acts of God or public authority, labor disputes, accidents, fires, floods, extreme weather conditions, failure of and delays by carriers, shortages of material, delays of a supplier, and any other cause beyond Seller's control. In no event shall Seller be liable for consequential or special damages arising out of a delay in or failure of delivery. Failure to meet estimated ship dates will not be considered sufficient cause of cancellation of orders.
9. **Cancellations and Returned Goods:** Permission to return any part or product must be obtained from Seller and may be subject to a restocking charge. Credits for new material accepted for return will be at the original sales price or current market price, whichever is lower, less handling and restocking charges. Buyer must prepay all transportation charges. Any costs for putting material in condition for resale will be charged to the Buyer. Shipment of material returned without factory authorization or not properly tagged with a Return Material Authorization Number or not freight prepaid cannot be received by Seller. Obsolete products or material made to special order are not returnable.
10. **Catalog Materials and Drawings:** Seller is not responsible for typographical errors or other errors of omission in Seller's catalogs or drawings.
11. **Late Charge Provision:** Buyer agrees to pay a late charge of 1-1/2% per month (18% per year) for any invoice or bill not paid within (30) thirty days of the date of the billing invoice.
12. **Choices of law, Disputes:** This agreement and the performance of the parties hereunder shall be construed in accordance with and governed by the laws of the State of Georgia and shall be deemed made in the state. Buyer irrevocably consents to the exclusive jurisdiction of the courts of Fulton County, on all matters arising out of or relating to this sale and Buyer further irrevocably consents to service of process by certified mail, return receipt requested, at Buyer's address set forth in the order acknowledgment.

The above terms and conditions apply to all orders placed with the Seller. Buyer acknowledges having read and understood these terms and conditions and agrees to abide by them upon placement of any order with the Seller. In the event it becomes necessary to refer the account to a collection agency or to institute legal action to obtain payment of the account, Buyer agrees to pay all reasonable attorney fees and court costs incurred by such action.

