



**LIST PRICES
3 - 22 HP
NEXT-GEN II
AIR COOLED CONDENSING UNITS**

ALL PRODUCTS, EXCEPT SURFACE COILS AND PARTS, ARE SHIPPED F.O.B. POINT OF SHIPMENT WITH FULL FREIGHT ALLOWED ON SINGLE ORDERS WITH A NET PRICE VALUE OF \$7000 OR MORE, WITHIN THE CONTINENTAL USA (EXCLUDING ALASKA AND HAWAII). ANY ADDITIONAL COSTS INCURRED FOR SPECIAL ROUTING AND HANDLING REQUESTS WILL BE INVOICED.

INDEX

PAGE	DESCRIPTION
2	NEXT-GEN II PRODUCT DESCRIPTION, NOMENCLATURE, AND LIST PRICES
3	OPTIONAL COMPONENTS
4	ELECTRIC DEFROST KIT DESCRIPTION
5	ELECTRIC DEFROST KIT LIST PRICES
6-7	BLANK NOTES PAGES
BACK COVER	TERMS & CONDITIONS

Due to ongoing product development, specification and prices are subject to change without notice.



TELEPHONE (770) 788-5800
FAX ORDER HOTLINE (770) 788-5820

Call or email us for help with replacement parts at: parts@htpgusa.com

Visit us on the web at: <http://kramer.htpgusa.com>

NEXT-GEN II AIR COOLED CONDENSING UNITS

3 HP THRU 22 HP

Standard Features (all models):

- Copeland Discus™, Copeland Scroll™ or Bitzer Semi-Hermetic Compressor
- All weather G90 galvanized steel painted enclosure
- Open view, flow-through equipment guard
- Removable side panels for ease of service
- Generously sized high efficiency condenser, with enhanced copper tubes/and aluminum fins
- Liquid line kit with sealed filter/drier and sight glass with moisture indicator
- Easy access base mounted service valves placed external to cabinet
- Dual pressure (auto reset) controls with flexible Reflex® hoses
- Vertical receiver with isolation valves
- Integral liquid sub cooling circuit
- Suction line piping (filter optional)
- Refrigerant pressure relief valve
- Heavy duty three phase condenser fan motor(
- Crankcase heater
- Control circuit fuses
- Pump down toggle switch
- Large electrical panel with hinged door
- 208-230V control voltage
- Color coded point-to-point wiring
- Fan cycling on 2 fan KB models (only)
- Liquid injection / Demand Cooling™ for low temp compressors



Unit is shown with optional components mounted

KF models also include a Flooded Head Pressure Control Valve (70°F) as a standard feature

Optional Features (all models):

- Electronic air defrost timer
- Electric defrost kits
- Mechanical timer in lieu of electronic timer
- 50 Hz timer and/or defrost kit
- Current sensing relay
- Thru the door Non-fused disconnect
- Suction line filter (sealed)
- Suction accumulator
- Oil separator
- Replaceable core liquid filter with bypass
- Replaceable core suction filter with bypass
- External fused or non-fused disconnect - loose or mounted
- Heated and insulated receiver (Temp controlled with low pressure bypass timer)
- Oversized receiver
- Insulated receiver
- Hail / Snow Guard - shipped loose (only)
- 316 Grade stainless steel housing
- Crankcase pressure regulator

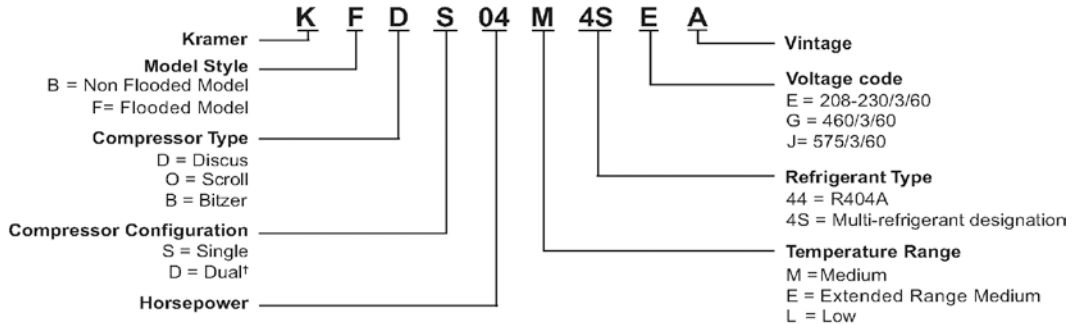

† Available with Dual Compressor set-up. Contact Application Engineering for model definition and special price quote.

Temp Range	Compressor (Discus™)	H.P.	KF		Model Number	KB		4 Year Compressor Protection Plan	Approx. Ship Wt. (LBS)
			Flooded Unit	List Price		Non Flooded	List Price		
Medium Temp Discus	2DC3R53K	04	KFDS04M4SEA	\$20,370	KBDS04M4SEA	\$19,426	\$454 NET	825	
			KFDS04M4SGA	\$21,638	KBDS04M4SGA	\$20,694			
			KFDS04M4SJA	\$22,072	KBDS04M4SJA	\$21,128			
	2DD3R63K	05	KFDS05M4SEA	\$20,737	KBDS05M4SEA	\$19,793	\$454 NET	850	
			KFDS05M4SGA	\$21,953	KBDS05M4SGA	\$21,009			
			KFDS05M4SJA	\$22,505	KBDS05M4SJA	\$21,561			
	2DL3R78K	06	KFDS06M4SEA	\$25,755	KBDS06M4SEA	\$24,811	\$550 NET	1075	
			KFDS06M4SGA	\$27,548	KBDS06M4SGA	\$26,604			
			KFDS06M4SJA	\$28,096	KBDS06M4SJA	\$27,152			
	2DA3R89K	7.5	KFDS07M4SEA	\$26,301	KBDS07M4SEA	\$25,357	\$558 NET	1100	
			KFDS07M4SGA	\$27,910	KBDS07M4SGA	\$26,966			
			KFDS07M4SJA	\$28,459	KBDS07M4SJA	\$27,515			
	3DA3R10M	7.5	KFDS08M4SEA	\$29,497	KBDS08M4SEA	\$28,553	\$558 NET	1130	
			KFDS08M4SGA	\$31,264	KBDS08M4SGA	\$30,320			
			KFDS08M4SJA	\$31,901	KBDS08M4SJA	\$30,957			
	3DB3R12M	10	KFDS10M4SEA	\$31,630	KBDS10M4SEA	\$30,686	\$721 NET	1330	
			KFDS10M4SGA	\$33,268	KBDS10M4SGA	\$32,324			
			KFDS10M4SJA	\$33,881	KBDS10M4SJA	\$32,937			
	3DF3R15M	12	KFDS12M4SEA	\$34,264	KBDS12M4SEA	\$33,320	\$865 NET	1330	
			KFDS12M4SGA	\$35,605	KBDS12M4SGA	\$34,661			
			KFDS12M4SJA	N/A	KBDS12M4SJA	N/A			
	3DS3R17M	15	KFDS15M4SEA	\$35,699	KBDS15M4SEA	\$34,755	\$1,116 NET	1350	
			KFDS15M4SGA	\$36,904	KBDS15M4SGA	\$35,960			
			KFDS15M4SJA	\$37,531	KBDS15M4SJA	\$36,587			

Voltage codes: E = 208-230/3/60, G = 460V/3/60, J = 575V/3/60

* See next page for condensing units with low temp Discus™ or Scroll™ compressors.

NEXT-GEN II AIR COOLED CONDENSING UNITS

3 HP THRU 22 H.P. - DISCUS™ and SCROLL™

Temperature Range	Compressor (Discus™)	H.P.	Model Number	KF Flooded List Price
Low Temp Discus	2DF3F16K	03	KFDS03L4SEA	\$22,635
			KFDS03L4SGA	\$24,035
			KFDS03L4SJA	\$24,546
	2DL3F20K	04	KFDS04L4SEA	\$24,582
			KFDS04L4SGA	\$26,002
			KFDS04L4SJA	\$26,462
	2DA3F23K	05	KFDS05L4SEA	\$25,117
			KFDS05L4SGA	\$26,730
			KFDS05L4SJA	\$27,212
	3DA3F28K	06	KFDS06L4SEA	\$27,170
			KFDS06L4SGA	\$28,795
			KFDS06L4SJA	\$29,442
	3DB3F33K	08	KFDS08L4SEA	\$30,126
			KFDS08L4SGA	\$31,438
			KFDS08L4SJA	\$32,432
	3DF3F40K	9	KFDS09L4SEA	\$33,425
			KFDS09L4SGA	\$35,257
			KFDS09L4SJA	\$35,907
	3DS3F46K	10	KFDS10L4SEA	\$36,077
			KFDS10L4SGA	\$36,659
			KFDS10L4SJA	\$37,517
	4DBNF54K	12	KFDS12L4SEA	\$36,746
			KFDS12L4SGA	\$37,529
			KFDS12L4SJA	\$38,235
4DHNF63K	15	KFDS15L4SEA	\$38,497	
		KFDS15L4SGA	\$39,071	
		KFDS15L4SJA	\$39,841	
4DJNF76K	22	KFDS22L4SEA	\$43,307	
		KFDS22L4SGA	\$43,992	
		KFDS22L4SJA	\$45,050	

Model Number	KB Non Flooded List Price	4 Year Compressor Protection Plan	Approx. Ship Wt. (LBS)
KBDS03L4SEA	\$21,691	\$306 NET	710
KBDS03L4SGA	\$23,091		
KBDS03L4SJA	\$23,602		
KBDS04L4SEA	\$23,638	\$454 NET	760
KBDS04L4SGA	\$25,058		
KBDS04L4SJA	\$25,518		
KBDS05L4SEA	\$24,173	\$454 NET	805
KBDS05L4SGA	\$25,786		
KBDS05L4SJA	\$26,268		
KBDS06L4SEA	\$26,226	\$550 NET	870
KBDS06L4SGA	\$27,851		
KBDS06L4SJA	\$28,498		
KBDS08L4SEA	\$29,182	\$558 NET	1130
KBDS08L4SGA	\$30,494		
KBDS08L4SJA	\$31,488		
KBDS09L4SEA	\$32,481	\$721 NET	1275
KBDS09L4SGA	\$34,313		
KBDS09L4SJA	\$34,963		
KBDS10L4SEA	\$35,133	\$821 NET	1275
KBDS10L4SGA	\$35,715		
KBDS10L4SJA	\$36,573		
KBDS12L4SEA	\$35,802	\$865 NET	1290
KBDS12L4SGA	\$36,585		
KBDS12L4SJA	\$37,291		
KBDS15L4SEA	\$37,556	\$1,116 NET	1310
KBDS15L4SGA	\$38,127		
KBDS15L4SJA	\$38,897		
KBDS22L4SEA	\$42,363	\$1,382 NET	1420
KBDS22L4SGA	\$43,048		
KBDS22L4SJA	\$44,106		

Temperature Range	Compressor (Scroll™)	NOM H.P.	Model Number	KF Flooded LIST PRICE
Medium Temp Scroll	ZS29KAE	04	KFOS04E4SEA	\$18,721
			KFOS04E4SGA	\$20,200
			KFOS04E4SJA	\$20,637
	ZS33KAE	05	KFOS05E4SEA	\$19,054
			KFOS05E4SGA	\$20,507
			KFOS05E4SJA	\$21,003
	ZS38K4E	06	KFOS06E4SEA	\$21,713
			KFOS06E4SGA	\$23,454
			KFOS06E4SJA	\$23,948
	ZS45K4E	07	KFOS07E4SEA	\$22,136
			KFOS07E4SGA	\$23,785
			KFOS07E4SJA	\$24,279
	ZB58K5E	08	KFOS08E4SEA	\$22,574
			KFOS08E4SGA	\$24,242
			KFOS08E4SJA	\$24,769
	ZB66K5E	09	KFOS09E4SEA	\$23,825
			KFOS09E4SGA	\$25,316
			KFOS09E4SJA	\$25,819
	ZB76K5E	10	KFOS10E4SEA	\$27,853
			KFOS10E4SGA	\$28,912
			KFOS10E4SJA	\$29,506
	ZB95K5E	13	KFOS13E4SEA	\$30,848
			KFOS13E4SGA	\$30,919
			KFOS13E4SJA	\$31,929
ZB114K5E	15	KFOS15E4SEA	\$34,443	
		KFOS15E4SGA	\$36,016	
		KFOS15E4SJA	\$36,719	

Model Number	KB Non Flooded List Price	4 Year Compressor Protection Plan	Approx. Ship Wt. (LBS)
KBOS04E4SEA	\$17,777	\$264 NET	700
KBOS04E4SGA	\$19,256		
KBOS04E4SJA	\$19,693		
KBOS05E4SEA	\$18,110	\$264 NET	710
KBOS05E4SGA	\$19,563		
KBOS05E4SJA	\$20,059		
KBOS06E4SEA	\$20,769	\$271 NET	710
KBOS06E4SGA	\$22,510		
KBOS06E4SJA	\$23,004		
KBOS07E4SEA	\$21,192	\$448 NET	870
KBOS07E4SGA	\$22,841		
KBOS07E4SJA	\$23,335		
KBOS08E4SEA	\$21,630	\$448 NET	915
KBOS08E4SGA	\$23,298		
KBOS08E4SJA	\$23,825		
KBOS09E4SEA	\$22,881	\$485 NET	980
KBOS09E4SGA	\$24,372		
KBOS09E4SJA	\$24,875		
KBOS10E4SEA	\$26,909	\$485 NET	1085
KBOS10E4SGA	\$27,968		
KBOS10E4SJA	\$28,562		
KBOS13E4SEA	\$29,904	\$560 NET	1105
KBOS13E4SGA	\$29,975		
KBOS13E4SJA	\$30,985		
KBOS15E4SEA	\$33,499	\$571 NET	1200
KBOS15E4SGA	\$35,072		
KBOS15E4SJA	\$35,775		

Low Temp Scroll	ZF25K4E	08	KFOS08L4SEA	\$21,332
			KFOS08L4SGA	\$22,594
			KFOS08L4SJA	\$23,036
	ZF34K5E	10	KFOS10L4SEA	\$26,478
			KFOS10L4SGA	\$28,036
			KFOS10L4SJA	\$28,611
	ZF41K5E	13	KFOS13L4SEA	\$29,927
			KFOS13L4SGA	\$30,440
			KFOS13L4SJA	\$31,269
	ZF49K5E	15	KFOS15L4SEA	\$30,922
			KFOS15L4SGA	\$31,620
			KFOS15L4SJA	\$32,251

KBOS08L4SEA	\$20,388	\$448 NET	850
KBOS08L4SGA	\$21,650		
KBOS08L4SJA	\$22,092		
KBOS10L4SEA	\$25,534	\$485 NET	1025
KBOS10L4SGA	\$27,092		
KBOS10L4SJA	\$27,667		
KBOS13L4SEA	\$28,983	\$560 NET	1050
KBOS13L4SGA	\$29,496		
KBOS13L4SJA	\$30,325		
KBOS15L4SEA	\$29,978	\$571 NET	1105
KBOS15L4SGA	\$30,676		
KBOS15L4SJA	\$31,307		

Voltage codes: E = 208-230/3/60, G = 460V/3/60, J = 575V/3/60

* See next Page for Condensing units with Bitzer Compressors

NEXT-GEN II AIR COOLED CONDENSING UNITS 3 HP THRU 22 H.P. - BITZER

Temperature Range	Compressor (Bitzer)	H.P.	Model Number	KF Flooded List Price
Medium Temp Bitzer	2DES-3	03	KFBS03E4SEA	\$22,352
			KFBS03E4SGA	\$23,818
			KFBS03E4SJA	\$24,039
	2CES-4	04	KFBS04E4SEA	\$22,704
			KFBS04E4SGA	\$24,118
			KFBS04E4SJA	\$24,460
	4FES-5	05	KFBS05E4SEA	\$23,071
			KFBS05E4SGA	\$24,433
			KFBS05E4SJA	\$24,883
	4EES-6	06	KFBS06E4SEA	\$25,288
			KFBS06E4SGA	\$26,243
			KFBS06E4SJA	\$27,938
	4DES-7	7.5	KFBS07E4SEA	\$27,474
			KFBS07E4SGA	\$28,022
			KFBS07E4SJA	\$30,962
	4CES-9	7.5	KFBS08E4SEA	\$30,962
			KFBS08E4SGA	\$32,510
			KFBS08E4SJA	\$33,209
	4TES-12	10	KFBS10E4SEA	\$31,335
			KFBS10E4SGA	\$33,186
			KFBS10E4SJA	\$33,799
	4PES-15	12	KFBS12E4SEA	\$32,667
			KFBS12E4SGA	\$34,370
			KFBS12E4SJA	\$34,983
4NES-20	15	KFBS15E4SEA	\$33,410	
		KFBS15E4SGA	\$35,045	
		KFBS15E4SJA	\$35,654	

Model Number	KB Non Flooded List Price	4 Year Compressor Protection Plan	Approx. Ship Wt. (LBS)
KBBS03E4SEA	\$21,408	\$454 NET	800
KBBS03E4SGA	\$22,874		
KBBS03E4SJA	\$23,095		
KBBS04E4SEA	21,760	\$454 NET	825
KBBS04E4SGA	23,174		
KBBS04E4SJA	23,516		
KBBS05E4SEA	22,127	\$454 NET	850
KBBS05E4SGA	23,489		
KBBS05E4SJA	23,939		
KBBS06E4SEA	24,344	\$550 NET	1075
KBBS06E4SGA	25,299		
KBBS06E4SJA	26,994		
KBBS07E4SEA	26,530	\$558 NET	1100
KBBS07E4SGA	27,078		
KBBS07E4SJA	30,018		
KBBS08E4SEA	30,018	\$558 NET	1130
KBBS08E4SGA	31,566		
KBBS08E4SJA	32,265		
KBBS10E4SEA	30,391	\$721 NET	1330
KBBS10E4SGA	32,242		
KBBS10E4SJA	32,855		
KBBS12E4SEA	31,723	\$865 NET	1330
KBBS12E4SGA	33,426		
KBBS12E4SJA	34,039		
KBBS15E4SEA	32,466	\$1,116 NET	1350
KBBS15E4SGA	34,101		
KBBS15E4SJA	34,710		

Temperature Range	Compressor (Bitzer)	H.P.	Model Number	KF Flooded List Price
Low Temp Bitzer	4FES-3	03	KFBS03L4SEA	\$24,666
			KFBS03L4SGA	\$23,022
			KFBS03L4SJA	\$23,519
	4EES-4	04	KFBS04L4SEA	\$26,628
			KFBS04L4SGA	\$24,984
			KFBS04L4SJA	\$25,481
	4DES-5	05	KFBS05L4SEA	\$27,734
			KFBS05L4SGA	\$26,171
			KFBS05L4SJA	\$26,651
	4CES-6	06	KFBS06L4SEA	\$32,268
			KFBS06L4SGA	\$30,959
			KFBS06L4SJA	\$31,287
	4TES-9	08	KFBS08L4SEA	\$34,177
			KFBS08L4SGA	\$32,825
			KFBS08L4SJA	\$33,251
	4PES-12	09	KFBS09L4SEA	\$36,250
			KFBS09L4SGA	\$34,838
			KFBS09L4SJA	\$35,785
	4NES-14	10	KFBS10L4SEA	\$38,353
			KFBS10L4SGA	\$36,941
			KFBS10L4SJA	\$37,888
	4JE-15	12	KFBS12L4SEA	\$40,962
			KFBS12L4SGA	\$39,550
			KFBS12L4SJA	\$40,497
	4HE-18	15	KFBS15L4SEA	\$43,631
			KFBS15L4SGA	\$42,216
			KFBS15L4SJA	\$43,166
	4GE-23	22	KFBS22L4SEA	\$45,041
			KFBS22L4SGA	\$43,686
			KFBS22L4SJA	\$44,636

Model Number	KB Non Flooded List Price	4 Year Compressor Protection Plan	Approx. Ship Wt. (LBS)
KBBS03L4SEA	\$23,722	\$281 NET	710
KBBS03L4SGA	\$22,078		
KBBS03L4SJA	\$22,575		
KBBS04L4SEA	\$25,684	\$281 NET	760
KBBS04L4SGA	\$24,040		
KBBS04L4SJA	\$24,537		
KBBS05L4SEA	\$26,790	\$312 NET	805
KBBS05L4SGA	\$25,227		
KBBS05L4SJA	\$25,707		
KBBS06L4SEA	\$31,324	\$324 NET	870
KBBS06L4SGA	\$30,015		
KBBS06L4SJA	\$30,343		
KBBS08L4SEA	\$33,233	\$324 NET	1130
KBBS08L4SGA	\$31,881		
KBBS08L4SJA	\$32,307		
KBBS09L4SEA	\$35,306	\$324 NET	1275
KBBS09L4SGA	\$33,894		
KBBS09L4SJA	\$34,841		
KBBS10L4SEA	\$37,409	\$324 NET	1275
KBBS10L4SGA	\$35,997		
KBBS10L4SJA	\$36,944		
KBBS12L4SEA	\$40,018	\$439 NET	1290
KBBS12L4SGA	\$38,606		
KBBS12L4SJA	\$39,553		
KBBS15L4SEA	\$42,687	\$545 NET	1310
KBBS15L4SGA	\$41,272		
KBBS15L4SJA	\$42,222		
KBBS22L4SEA	\$41,676	\$620 NET	1420
KBBS22L4SGA	\$42,742		
KBBS22L4SJA	\$43,692		

Voltage codes: E = 208-230/3/60, G = 460V/3/60, J = 575V/3/60

3-22 H.P. CONDENSING UNITS - FACTORY INSTALLED DEFROST KITS

1 EVAPORATOR PER CU	Max Defrost Load (Amps per evap.)	List Price
DMA15	15	\$1,224
DMA20	20	
DMA24	24	
DMA30	30	
DMA35	35	\$1,366
DMA40	40	
DMA48	48	
DMB60	60	\$2,666
DMB96	96	

2 EVAPS PER CU	Max Defrost Load (Amps per evap.)	List Price
DMB35	35	\$1,853
DMB40	40	
DMB48	48	
DMB60	60	\$2,666
DMB96	96	

3 EVAPS PER CU	Max Defrost Load (Amps per evap.)	List Price
DMC35	35	\$2,788
DMC40	40	
DMC48	48	
DMC60	60	\$3,448
DMC96	96	

AIR DEFROST TIMER:	\$532
---------------------------	-------

Note: All electric defrost kits include 1 fan contactor and are suitable for single or three phase loads. Defrost amp values are the maximum load for a kit. Smaller loads may be attached.

3-22 H.P. CONDENSING UNITS - FACTORY INSTALLED OPTIONS[†]

[†]All options are factory mounted unless otherwise noted.

	OPTION NUMBER	H.P. RANGE	LIST PRICE [†]
Electrical options			
THROUGH THE DOOR NON-FUSED DISCONNECT SWITCH	TDNM-3	3-10	\$1,492
	TDNM-4	12-22	\$1,668
EXTERNAL FUSED DISCONNECT - Loose or Mounted	EFDM-2 (230V)	3 - 6	\$964
	EFDM-3 (230V)	7 - 10	\$1,148
	EFDM-4 (230V)	12 - 22	\$2,448
	EFDM-2 (460V)	3 - 6	\$1,133
	EFDM-3 (460V)	7 - 10	\$2,040
	EFDM-4 (460V)	12 - 22	\$3,366
MAIN CIRCUIT BREAKER *In lieu of power block	BKR-2	3 - 6	\$1,377
	BKR-3	7 - 10	\$1,734
	BKR-4	12 - 22	\$2,183
PHASE LOSS MONITOR	PLM	ALL	\$1,085
SINGLE POINT ALARM	SPA	ALL	\$356
ANTI SHORT CYCLE TIMER	ASC	ALL	\$629
EC FAN MOTORS (single speed) - Not available for 575V.	ECM-1	1 FAN	\$461
	ECM-2	2 FAN	\$922
EC FAN MOTORS (with variable speed controller) - Not available for 575V.	VCM-1	1 FAN	\$1,097
	VCM-2	2 FAN	\$2,194
CURRENT SENSING RELAY (Run proof)	CSR	All	\$710
FAN CYCLE CONTROL - 230V (kB Models only)	FC-2	6 - 22	\$398
FAN CYCLE CONTROL - 460V (kB Models only) *Fan cycling is not available for single fan models.	FC-4	6 - 22	\$453
COMPRESSOR UNLOADERS (Suction pressure control. Reciprocating compressors only.)	UNL-1	When Available	\$1,995
COMPRESSOR FUSING	CFS	ALL	\$413

Mechanical options

SUCTION LINE FILTER (Sealed)	SK-5	3 - 8	\$467
	SK-6	9 - 10	\$793
	SK-7	12 - 22	\$1,265
REPLACEABLE CORE SUCTION FILTER (With Bypass)	RSK-5	3 - 8	\$1,051
	RSK-6	9 - 10	\$1,346
	RSK-7	12 - 22	\$1,898
REPLACEABLE CORE LIQUID FILTER (With Bypass)	RLK-5	3 - 8	\$1,103
	RLK-6	9 - 10	\$1,376
	RLK-7	12 - 22	\$1,993
SUCTION LINE ACCUMULATOR (Must add Suction line filter option.)	ASK-4	3 - 8	\$754
	ASK-5	9 - 10	\$1,109
	ASK-6	12 - 22	\$2,318
OIL SEPARATOR	OS-1	3 - 6	\$1,285
	OS-2	7 - 10	\$1,369
	OS-3	12 - 22	\$1,609
OVERSIZED RECEIVERS	OSR-1	1 FAN	\$1,134
	OSR-2	2 FAN	\$635
	OSR-3	2 FAN TALL	\$403
HEATED AND INSULATED RECEIVER (Temperature controlled with low pressure bypass timer)	HIR	ALL	\$746
CRANKCASE PRESSURE REGULATOR	CPR VALVE	3 - 5	\$1,479
		6 - 9	\$1,641
		10 - 15	\$3,056
		22	\$3,056
STAINLESS STEEL BRAIDED CONTROL HOSES	SSH	ALL	\$356
LIQUID INJECTION / DEMAND COOLING™ PRICE DEDUCT - to optionally remove the feature from low temperature models (Not available for Scroll™ compressors)	LNJ-deduct	ALL	\$2,421
LIQUID LINE SOLENOID (Mounted LLS should only be applied to close coupled systems. Not more than 25' line run.)	LLS-1	3	\$270
	LLS-2	4 - 8	\$302
	LLS-3	9 - 10	\$437
	LLS-4	12 - 15	\$540
	LLS-5	22	\$689
HAIL / SNOW GUARDS (Shipped loose to prevent shipping damage. Requires field installation)	SG-E	1 FAN	\$897
	SG-F	2 FAN	\$1,226
	SG-G	2 FAN TALL	\$1,374
2 UNIT STACKING RACK (Shipped empty. Condensing units must be field installed.)	SR-2	1 or 2 FAN	\$5,057
3 UNIT STACKING RACK (Shipped empty. Condensing units must be field installed.)	SR-3	1 or 2 FAN	\$6,486

Contact Application Engineering for a special quote on options not found in the price list.

PRINCIPAL TERMS AND CONDITIONS OF SALE

1. **Applicable Law and Terms of Sale:** All orders shall be subject to the following terms and conditions notwithstanding any additional or contrary printed terms and conditions of Buyer. Such additional or contrary terms shall not bind Seller unless accepted in writing even though such terms do not materially alter the terms hereof. No oral statements, warranties, stipulations, representations or terms shall have any binding effect or be any part of the contract whatsoever.
2. **Orders:** All orders must be in writing and will be binding when our order acknowledgment is mailed. Orders are accepted subject to strikes, fires, accidents, and other causes beyond our reasonable control. Acceptance of your order is conditioned upon an agreement to hold us harmless by reason of delivery delays. Minimum order charge is \$50.00.
3. **Prices:** Prices are subject to change without notice, and all quotations, unless otherwise specified, are binding only for immediate acceptance. Prices are based on material made to Seller's standard tolerances, unless otherwise specified.
4. **Freight:** All products are shipped FOB Point of Shipment. Routing and selection of carrier will be made by Seller. For special routing requests Buyer will bear all additional costs for such routing. Equipment is shipped at Buyer's risk. Buyer should examine equipment before signing transportation receipt. If equipment is received damaged or if quantity received does not match freight bill, the Buyer should require agent to so indicate on freight bill and immediately file a damage/missing claim. Our liability ceases upon delivery of equipment in good order to the freight carrier. Full freight is allowed on shipments with a net price value of \$7000.00 or more, except surface coils and parts within the continental U.S.A. excluding Alaska and Hawaii.
5. **Taxes:** Any sales, use, excise, or similar tax payable by Seller which is or may be imposed by any taxing authority upon manufacture, sale or delivery of goods covered by any order or any increase in rate of any such tax now in force shall be added to the sales price; if not collected at the time of payment of sales price, Buyer will hold Seller harmless.
6. **Limited Warranty:** Seller warrants against defect in materials and workmanship in products which it manufactures for (1) year from date of installation or up to (18) eighteen months from the date of shipment, whichever event occurs first, when properly installed and operated under normal use. This guarantee does not include any labor or other charges made outside of the Seller's factory for replacement or repair of defective parts unless specifically stated in the body of the Seller's invoice. On parts not manufactured by Seller, such as motors, controls, valves and compressors we extend to the Buyer the same warranties made to us by the manufacturer. Seller's only liability under this warranty or otherwise shall be the repair or replacement (at Seller's option) of non-conforming goods or parts. Seller assumes no liability for incidental or consequential damages such as injury to person or property, or lost profits.
7. **THIS GUARANTEE SUPERSEDES AND IS IN LIEU OF ANY AND ALL OTHER WARRANTIES BY LAW OR CUSTOM, EITHER EXPRESSED OR IMPLIED INCLUDING, BUT NOT LIMITED BY THIS ENUMERATION, ANY GUARANTEE AS TO QUALITY OR FITNESS FOR ANY PARTICULAR PURPOSE, EXCEPT AS SET FORTH ABOVE. NO PERSON, AGENT, OR DEALER IS AUTHORIZED TO GIVE ANY WARRANTIES ON BEHALF OF SELLER NOR TO ASSUME FOR SELLER ANY OTHER LIABILITY IN CONNECTION WITH ANY OF THE SELLER'S PRODUCTS.**
8. **Delivery:** Seller shall not be liable for any delays in or failure of delivery due to acts of God or public authority, labor disputes, accidents, fires, floods, extreme weather conditions, failure of and delays by carriers, shortages of material, delays of a supplier, and any other cause beyond Seller's control. In no event shall Seller be liable for consequential or special damages arising out of a delay in or failure of delivery. Failure to meet estimated ship dates will not be considered sufficient cause of cancellation of orders.
9. **Cancellations and Returned Goods:** Permission to return any part or product must be obtained from Seller. Credits for new material accepted for return will be at the original sales price or current market price, whichever is lower, less handling and restocking charges. Buyer must prepay all transportation charges. Any costs for putting material in condition for resale will be charged to the Buyer. Shipment of material returned without factory authorization or not properly tagged with Material Return Authorization Number or not freight prepaid cannot be received by Seller. Obsolete products or material made to special order are not returnable.
10. **Catalog Materials and Drawings:** Seller is not responsible for typographical errors or other errors of omission in Seller's catalogs or drawings.
11. **Late Charge Provision:** Buyer agrees to pay a late charge of 1-1/2% per month (18% per year) for any invoice or bill not paid within (30) thirty days of the date of the billing invoice.
12. **Choices of law, Disputes:** This agreement and the performance of the parties hereunder shall be construed in accordance with and governed by the laws of the State of Georgia and shall be deemed made in the state. Buyer irrevocably consents to the exclusive jurisdiction of the courts of Fulton County on all matters arising out of or relating to this sale and Buyer further irrevocably consents to service of process by certified mail, return receipt requested, at Buyer's address set forth in the order acknowledgement.

The above terms and conditions apply to all orders placed with the Seller. Buyer acknowledges having read and understood these terms and conditions and agrees to abide by them upon placement of any order with the Seller. In the event it becomes necessary to refer the account to a collection agency or to institute legal action to obtain payment of the account, Buyer agrees to pay all reasonable attorney fees and court costs incurred by such action.